

High Voltage Boost/SEPIC Controller

General Description

The RT8573 is a current mode PWM controller designed to drive an external MOSFET for high current LED applications. With a low side current sense amplifier threshold of 190mV, the LED current is programmable with one external current sense resistor.

With programmable operating frequency up to 800kHz, the external inductor and capacitors can be small while maintaining high frequency.

Dimming can be done by either analog or digital. A built-in clamping comparator and filter allow easy low noise analog dimming conversion from digital signal with only one external capacitor. An unique True PWM dimming control is made easy with MOSFET under LED string. A very high dimming ratio can be achieved by adopting both analog/digital dimming and True PWM dimming together.

The RT8573 is available in a SOP-16 package.

Ordering Information

RT8573 □□

- Package Type
S : SOP-16
- Operating Temperature Range
G : Green (Halogen Free with Commercial Standard)

Note :

Richtek Green products are :

- ▶ RoHS compliant and compatible with the current requirements of IPC/JEDEC J-STD-020.
- ▶ Suitable for use in SnPb or Pb-free soldering processes.

Marking Information

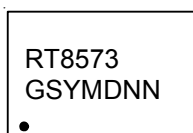

RT8573GS : Product Number
YMDNN : Date Code

Features

- High Voltage Capability : V_{IN} Up to 36V, V_{OUT} is limited by External MOSFET Switch
- Boost Operation
- Current Mode PWM with Programmable Switching Frequency
- Easy Dimming Control : Analog or Digital Converting to Analog with One External Capacitor
- True PWM Dimming : External FET Driver is Built-In
- Programmable Soft-Start to Avoid Inrush Current
- Programmable Over Voltage Protection
- V_{IN} Undervoltage Lockout and Thermal Shutdown
- 16-Lead SOP Package
- RoHS Compliant and Halogen Free

Applications

- General Industrial High Power LED Lighting
- Desk Lights and Room Lighting
- Building and Street Lighting
- Industrial Display Backlight

Pin Configurations

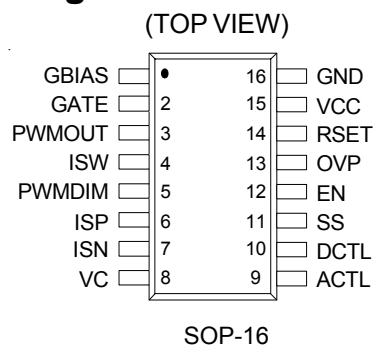

Typical Application Circuit

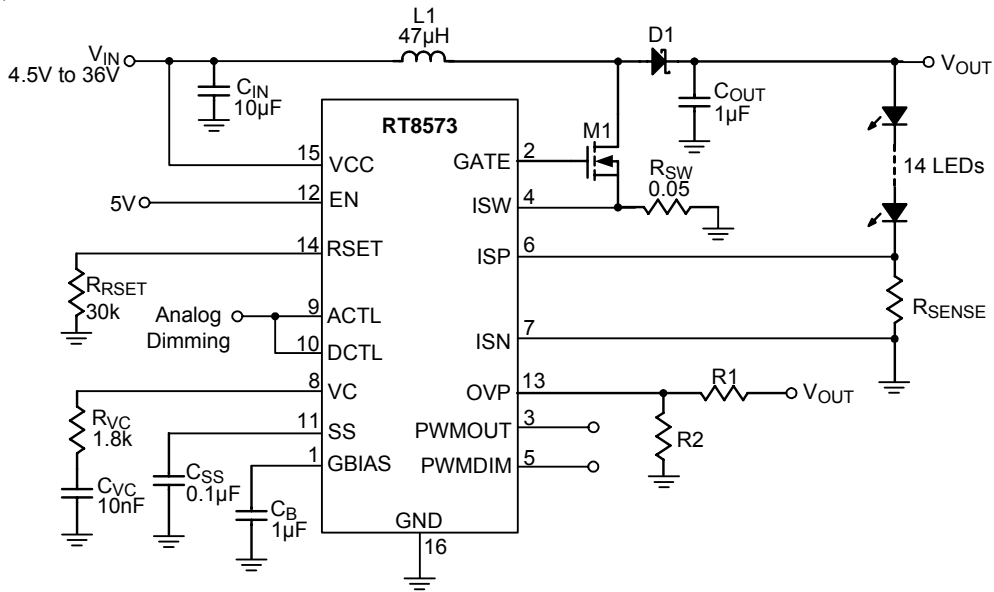

Figure 1. Analog Dimming in Boost Configuration

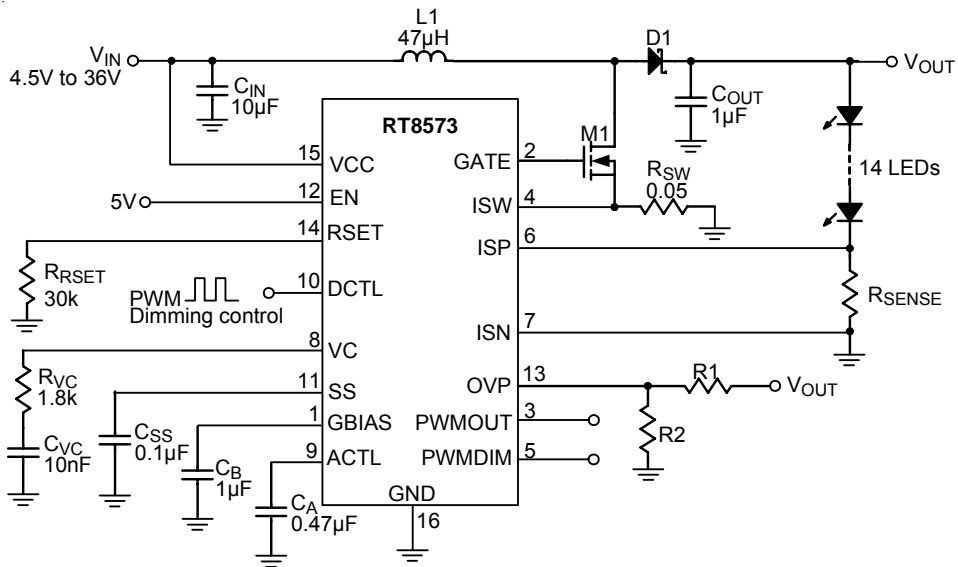

Figure 2. PWM to Analog Dimming in Boost Configuration

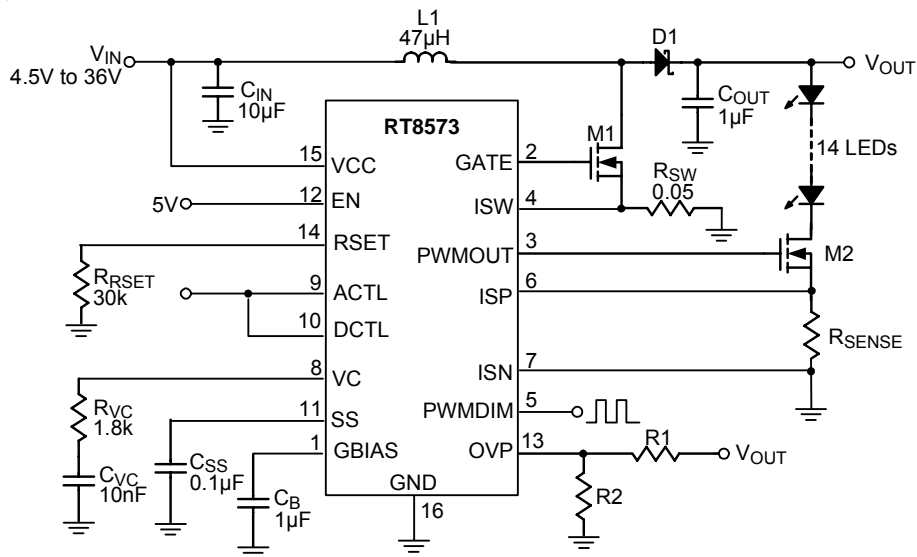

Figure 3. True PWM Dimming in Boost Configuration

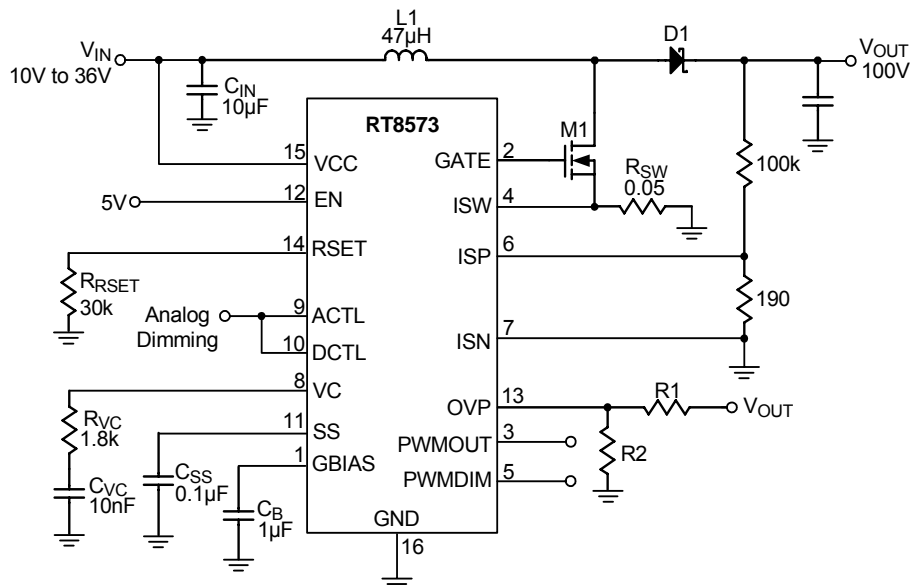

Figure 4. Constant Voltage Output of Boost Converter

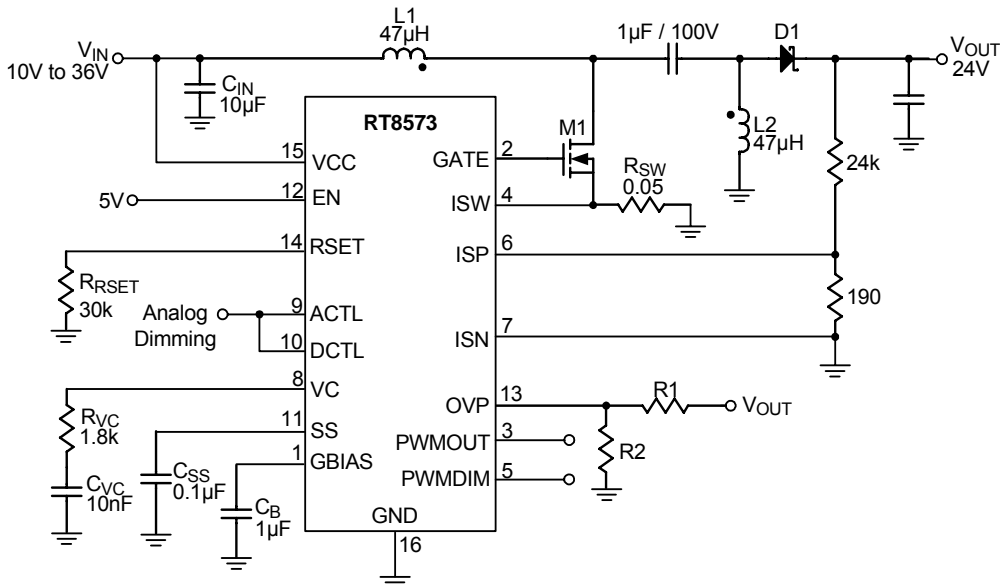
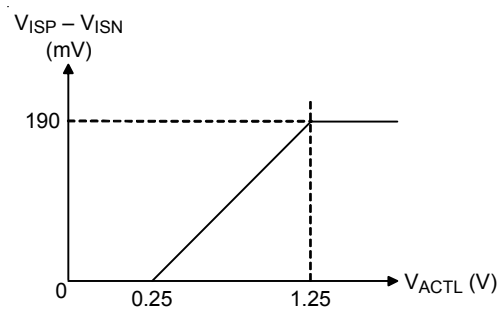
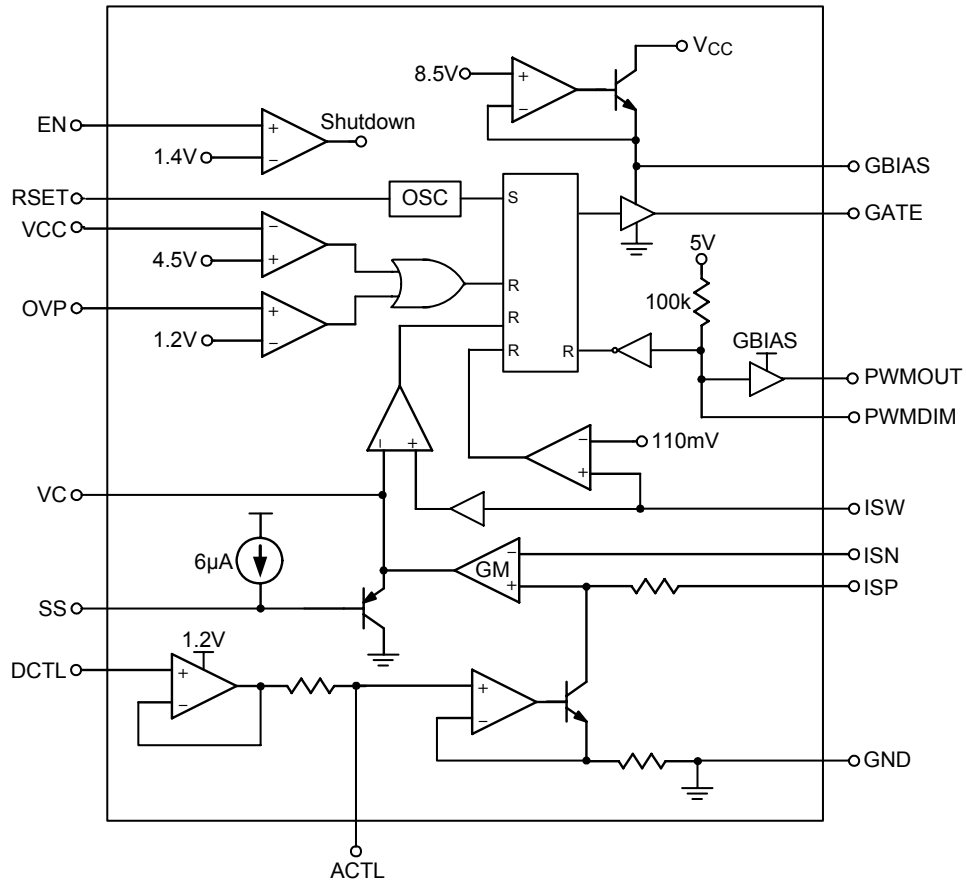

Figure 5. Constant Voltage Output of SEPIC Converter

Functional Pin Description

Pin No.	Pin Name	Pin Function
1	GBIAS	Internal Gate Driver Bias Pin. A good bypass capacitor is required.
2	GATE	External MOSFET Switch Gate Driver Output Pin.
3	PWMOUT	Output Pin for the PWM Dimming MOSFET Driver.
4	ISW	External MOSFET Switch Current Sense Pin. Connect the current sense resistor between external N-MOSFET switch and the ground.
5	PWMDIM	Control Input Pin for the PWM Dimming MOSRET Driver.
6	ISP	LED Current Sense Amplifier Positive Input.
7	ISN	LED Current Sense Amplifier Negative Input. Voltage threshold between ISP and ISN is 190mV.
8	VC	PWM Control Loop Compensation Pin.
9	ACTL	Analog Dimming Control Pin. The effective programming voltage range of the pin is between 0.3V and 1.2V.
10	DCTL	PWM Dimming Control Pin, By adding a 0.47µF filtering capacitor on the ACTL pin, the PWM dimming signal on the DCTL pin can be averaged and converted into analog dimming signal on the ACTL pin following the formula below. $V_{ACTL} = 1.2V \times \text{PWM Dimming Duty Cycle}$.
11	SS	Soft-Start Pin. A capacitor of at least 100nF is required for proper soft-start.
12	EN	Chip Enable (Active High). When this pin voltage is low, the chip is in shutdown mode.
13	OVP	Over Voltage Protection Pin. The PWM converter turns off when the voltage of the pin goes to higher than 1.2V.
14	RSET	Switching Frequency Set Pin connect a Resistor from RSET to GND. $f_{RSET} = 30k\Omega$ will set $f_{sw} = 380kHz$.
15	VCC	The Power Supply Pin of the Chip. For good bypass, a low ESR capacitor is required.
16	GND	Ground.

Function Block Diagram



Absolute Maximum Ratings (Note 1)

- Supply Input Voltage, V_{CC} ----- 38V
- GBIAS, GATE, PWMDIM, PWMOUT ----- 10V
- ISW
 - DC ----- 1V
 - < 200ns ----- 6V
- ISP, ISN
 - DC ----- 2V
 - < 200ns ----- 6V
- DCTL, ACTL, OVP Pin Voltage ----- 8V (Note 2)
- EN Pin Voltage ----- 20V
- Power Dissipation, $P_D @ T_A = 25^\circ C$
 - SOP-16 ----- 1.176W
- Package Thermal Resistance (Note 3)
 - SOP-16, θ_{JA} ----- 85°C/W
- Junction Temperature ----- 150°C
- Lead Temperature (Soldering, 10 sec.) ----- 260°C
- Storage Temperature Range ----- -65°C to 150°C
- ESD Susceptibility (Note 4)
 - HBM (Human Body Mode) ----- 2kV
 - MM (Machine Mode) ----- 200V

Recommended Operating Conditions (Note 5)

- Supply Input Voltage Range, V_{CC} ----- 4.5V to 36V
- Junction Temperature Range ----- -40°C to 125°C

Electrical Characteristics

($V_{CC} = 24V$, No Load, $T_A = 25^\circ C$, unless otherwise specified)

Parameter	Symbol	Test Conditions	Min	Typ	Max	Unit
Overall						
Supply Current	I_{CC}	$V_C \leq 0.4V$ (Switching Off)	--	6	7.2	mA
Shutdown Current	I_{SHDN}	$V_{EN} \leq 0.7V$	--	12	--	μA
EN Threshold Voltage	Logic-High		2	--	--	V
	Logic-Low		--	--	0.5	
EN Input Current		$V_{EN} \leq 3V$	--	--	3	μA
Current Sense Amplifier						
Input Threshold ($V_{ISP} - V_{ISN}$)			180	190	200	mV
ISP / ISN Input Current	I_{ISP} / I_{ISN}	$V_{ISP} - V_{ISN} = 0V$	--	20	--	μA
VC Output Current	I_{VC}	$V_{ISP} - V_{ISN} = 190mV$, $0.5V \leq V_C \leq 2.4V$	--	± 20	--	μA
VC Threshold for PWM Switch Off	S		--	0.7	--	V
LED Dimming						
ACTL Input Current	I_{ACTL}	$V_{ACTL} = 1.2V$	--	1	--	μA
		$V_{ACTL} = 0.3V$	--	10	--	

To be continued

Parameter	Symbol	Test Conditions	Min	Typ	Max	Unit
LED Current On Threshold at	V _{ACTL_ON}		--	1.25	–	V
LED Current Off Threshold at ACTL	V _{ACTL_OFF}		--	0.25	–	V
DCTL Input Current	I _{DCTL}	0.3V ≤ V _{DCTL} ≤ 6V	--	–	0.5	μA
PWM Control						
Switching Frequency	f _{SW}	R _{RSET} = 30kΩ	300	380	460	kHz
Minimum OFF Time (Note 6)			--	280	–	ns
Switch Gate Driver						
GBIAS Voltage	V _{GBIAS}	I _{GBIAS} = 20mA	--	8.2	–	V
Gate Voltage High	V _{Gate_H}	I _{Gate} = –20mA	--	7.2	–	V
		I _{Gate} = –100μA	--	7.5	–	
Gate Voltage Low	V _{Gate_L}	I _{Gate} = 100μA	--	0.5	–	V
GATE Drive Rise and Fall Time		1nF Load at GATE	--	15	–	ns
PWM Switch Current Limit Threshold	I _{LIM_SW}		--	90	–	mV
PWM Dimming Gate Driver						
PWMDIM Threshold Voltage	Logic-High	V _{PWMDIMH}	2	–	–	V
	Logic-Low	V _{PWMDIML}	--	–	0.5	
PWMOUT Output Voltage	V _{PWMOUTH}	I _{PWMOUT} = 1mA	--	7.5	–	V
	V _{PWMOUTL}	I _{PWMOUT} = –100μA	--	0.45	–	
PWMOUT Drive Rise and Fall Time		1nF Load at PWMOUT	--	40	–	ns
OVP and Soft-Start						
OVP Threshold	V _{OVP_th}		1.12	1.18	1.24	V
OVP Input Current	I _{OVP}	0.7V ≤ V _{OVP} ≤ 1.5V	--	–	0.1	μA
Soft-Start Current	I _{SS}	V _{SS} ≤ 2V	--	6	–	μA
Thermal Protection						
Thermal Shutdown	T _{SD}		--	145	–	°C
Thermal Shutdown Hysteresis	ΔT _{SD}		--	10	–	°C

Note 1. Stresses listed as the above “Absolute Maximum Ratings” may cause permanent damage to the device. These are for stress ratings. Functional operation of the device at these or any other conditions beyond those indicated in the operational sections of the specifications is not implied. Exposure to absolute maximum rating conditions for extended periods may remain possibility to affect device reliability.

Note 2. If connected with a 20kΩ serial resistor, ACTL and DCTL can go up to 36V.

Note 3. θ_{JA} is measured in natural convection at T_A = 25°C on a high-effective thermal conductivity four-layer test board of JEDEC 51-7 thermal measurement standard.

Note 4. Devices are ESD sensitive. Handling precaution is recommended.

Note 5. The device is not guaranteed to function outside its operating conditions.

Note 6. When the natural maximum duty cycle of the switching frequency is reached, the switching cycle will be skipped (not reset) as the operating condition requires to effectively stretch and achieve higher on cycle than the natural maximum duty cycle set by the switching frequency.

Typical Operating Characteristics

Efficiency vs. Input Voltage

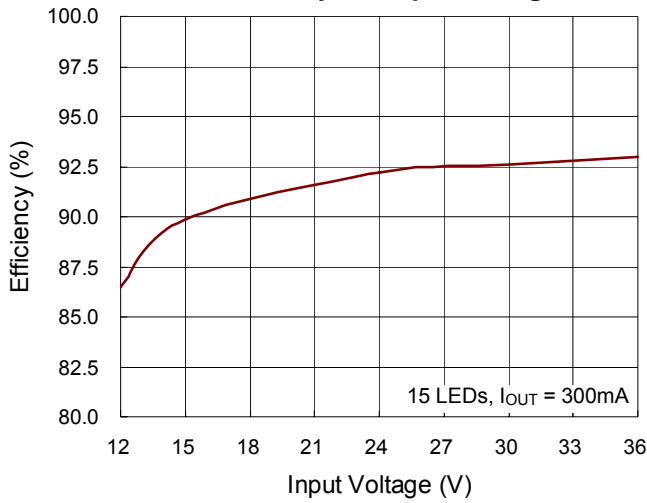

LED Current vs. ACTL PWM Duty

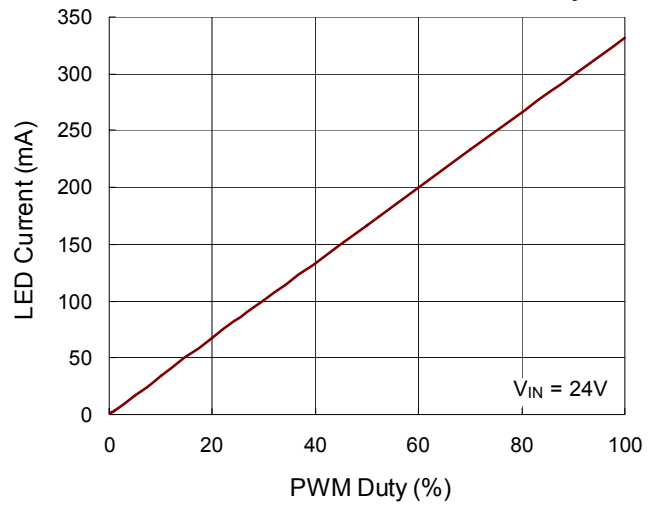

LED Current vs. Input Voltage

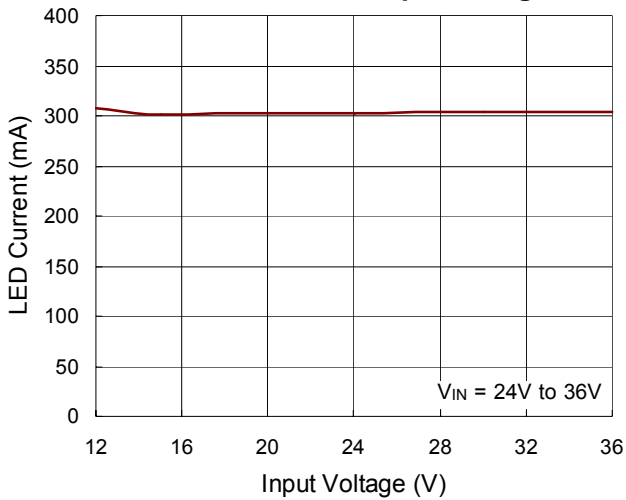

R_{SET} vs. Switching Frequency

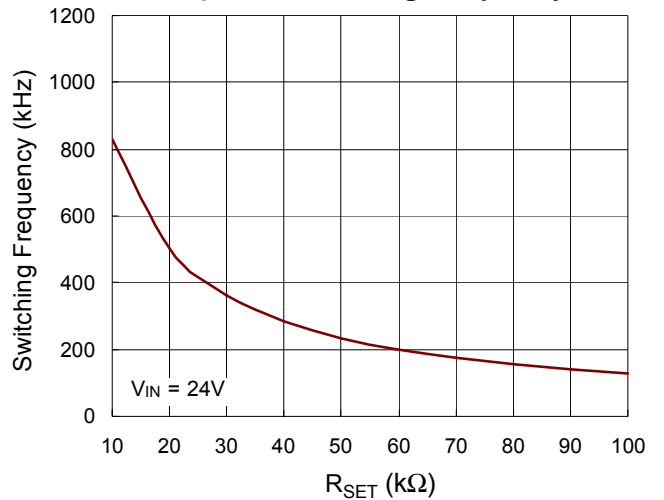

V_{ISP} - V_{ISN} Threshold vs. Input Voltage

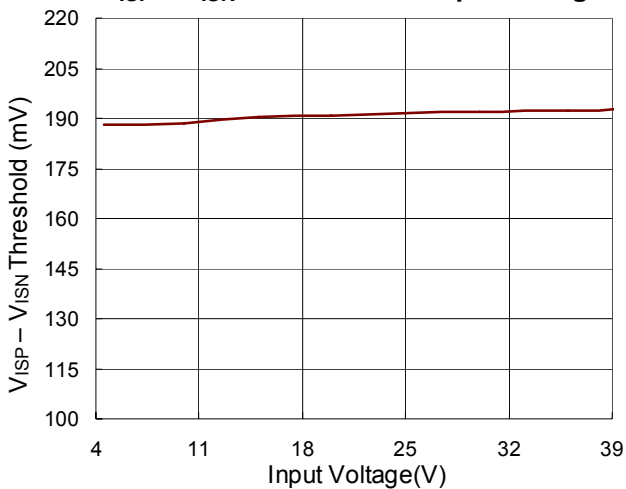

Switching Frequency vs. Input Voltage

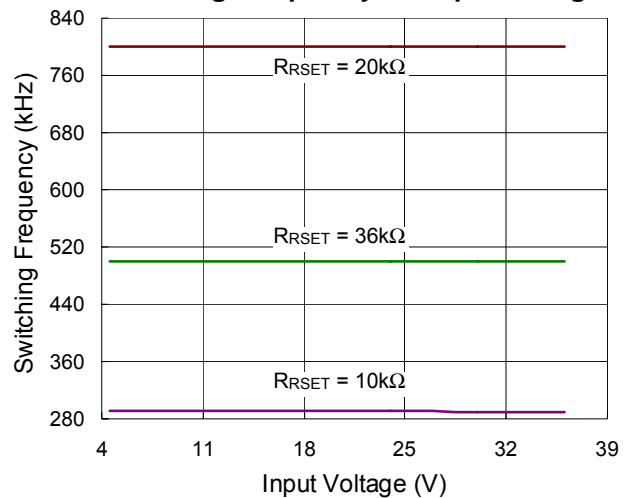

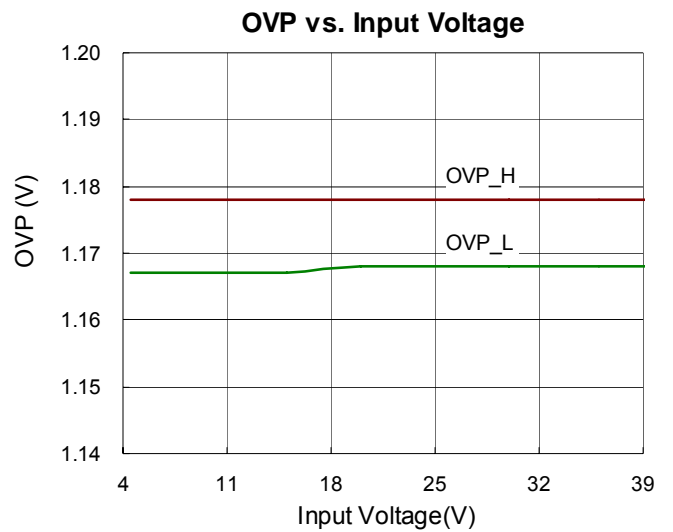
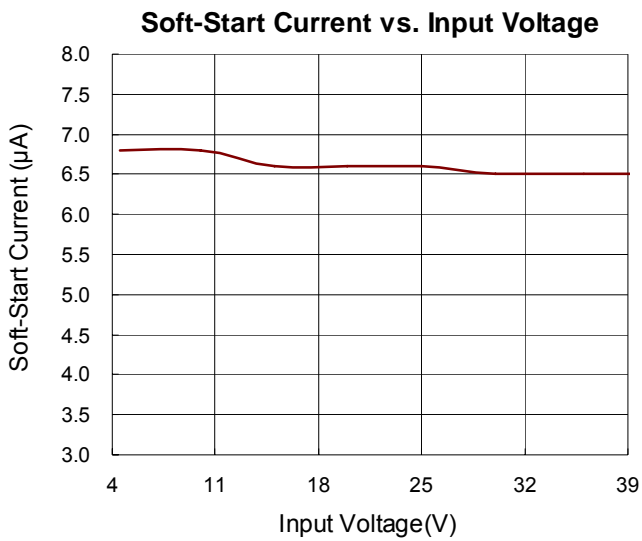
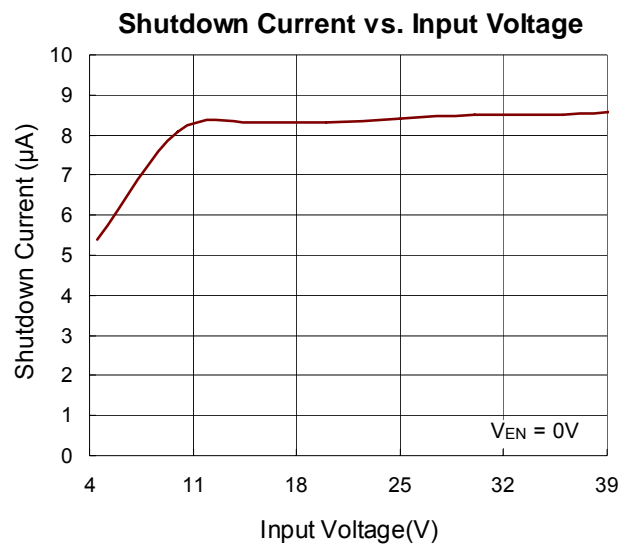
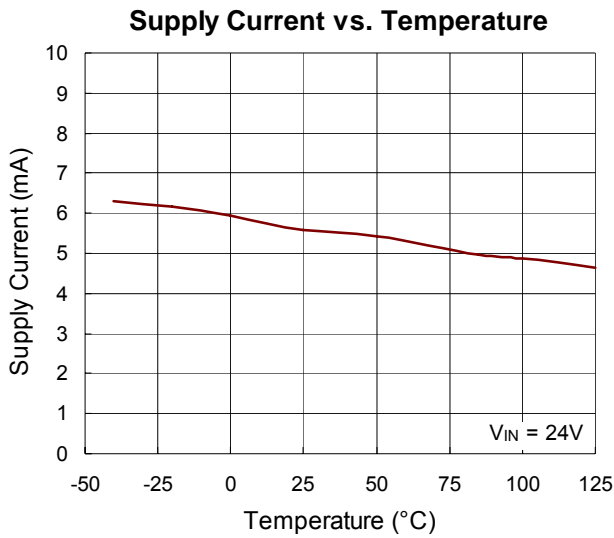
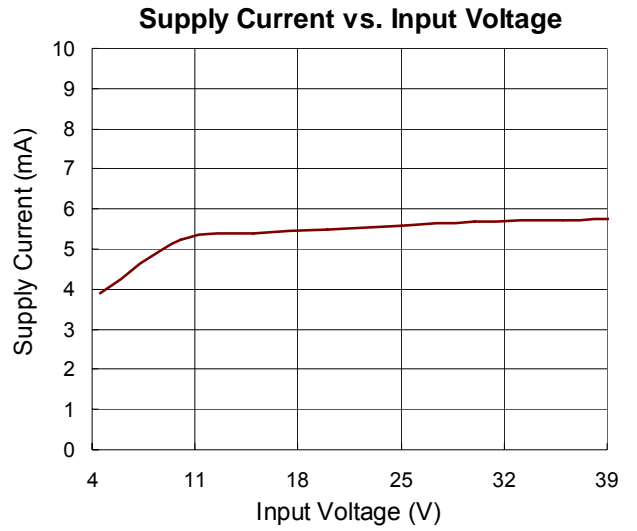
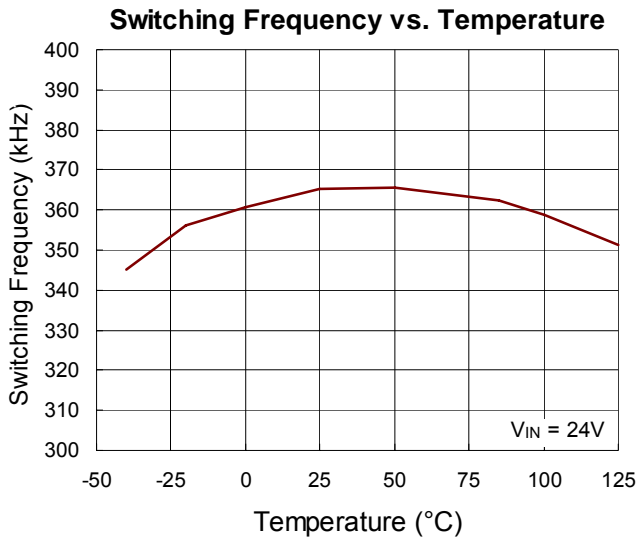

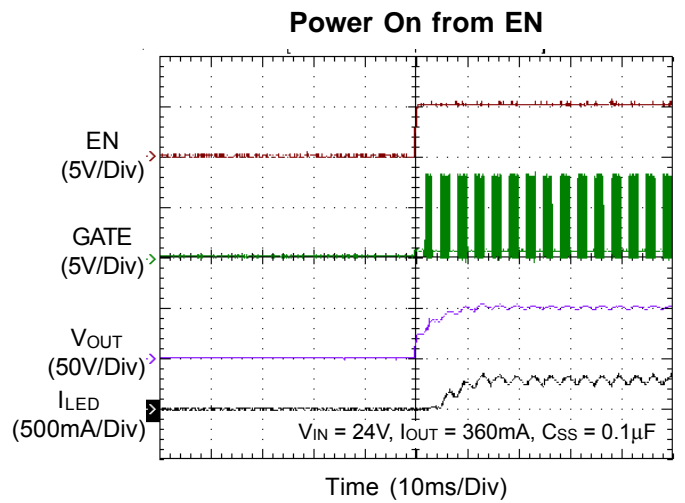
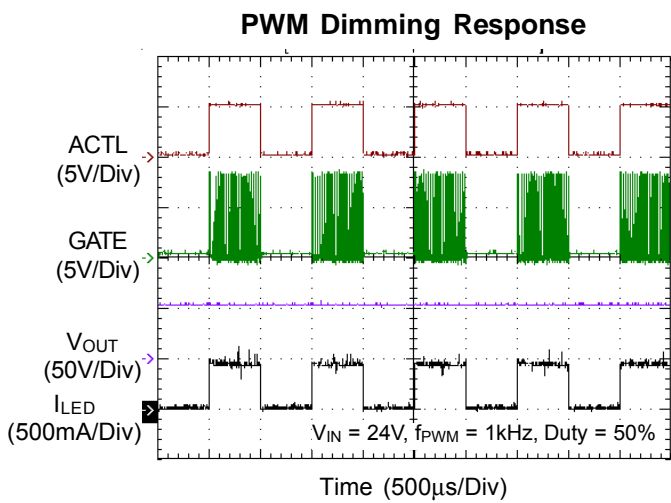
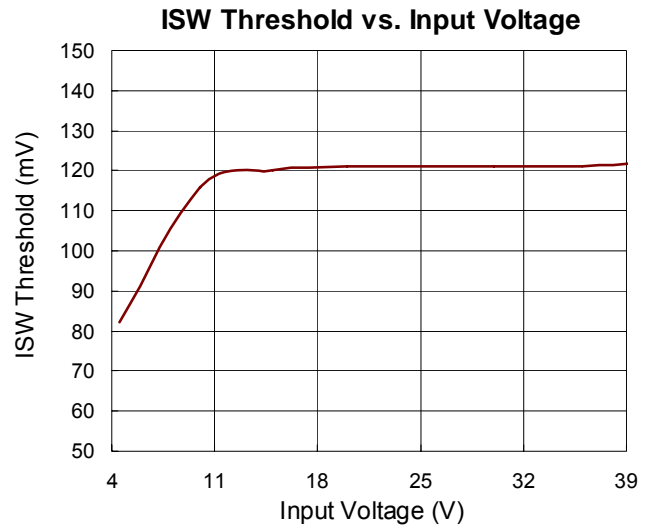
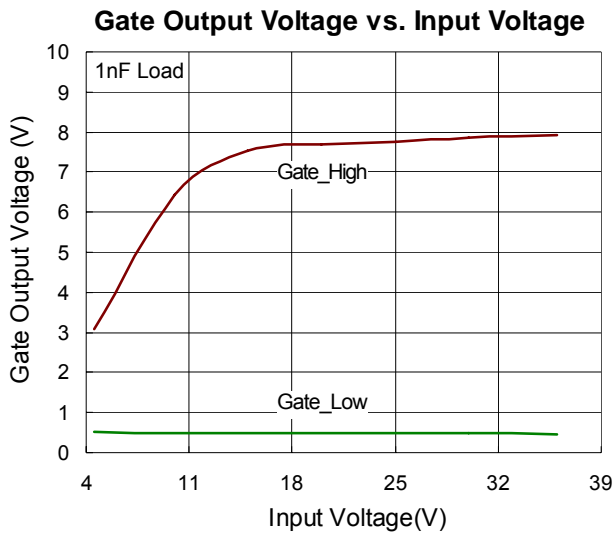
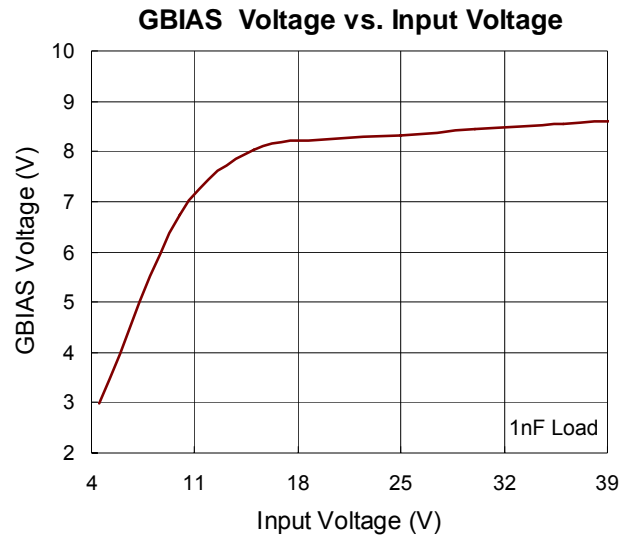
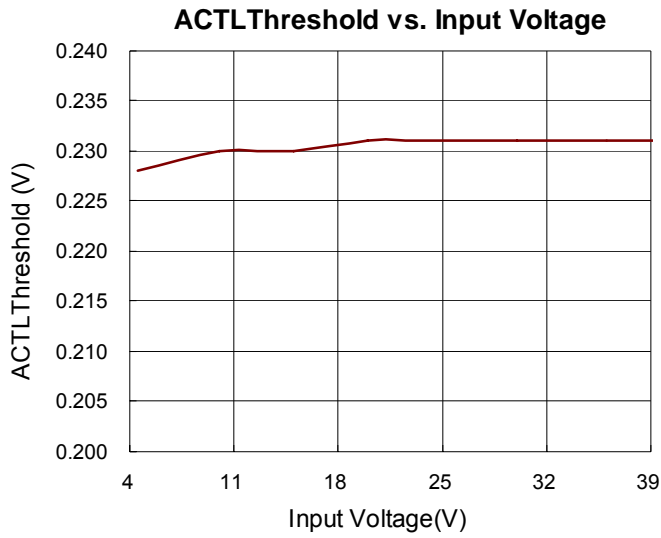

Application Information

The RT8573 is a constant frequency, current mode controller which drives an external MOSFET for PWM LED applications, DC/DC Boost, SEPIC and Flyback converter.

When using an external load switch, the PWMDIM input not only drives PWMOUT, but also enables controller GATE switching and error amplifier operation. This feature provides extremely fast, true PWM load switching with no transient overvoltage.

In normal operation with PWMDIM high, GATE goes high and the power MOSFET is turned on. When the oscillator sets the PWM latch, the power MOSFET is turned off when the VC current comparator resets the latch. When the load current increases, a fall in the ISN voltage relative to the reference voltage at ISP causes the VC pin to rise and the average inductor current will therefore rise until it equals the load current. When PWMDIM goes low, PWMOUT goes low, VC opens and GATE switching is disabled. Lowering PWMOUT and disabling GATE causes the output capacitor, C_{OUT} , to hold the output voltage constant in the absence of load current.

Input UVLO

The input operating voltage range of the RT8573 is 4.5V to 36V. An input capacitor at the VCC pin can reduce ripple voltage. It is recommended to use a ceramic 10 μ F or larger capacitance as the input capacitor. This IC provides an Under Voltage Lockout (UVLO) function to enhance the stability when startup. The UVLO threshold of input rising voltage is set at 4.5V typically with a 0.7V hysteresis.

Power Sequence

Please refer to below Figure 6 and 7. The recommended power-on sequence suggests the PWM to be ready before EN and/or VIN is ready. If not, the soft-start function will be disabled. As for power-off sequence, EN/VIN must be pulled low within 10ms to prevent "Hard-Start" as shown Figure 8.

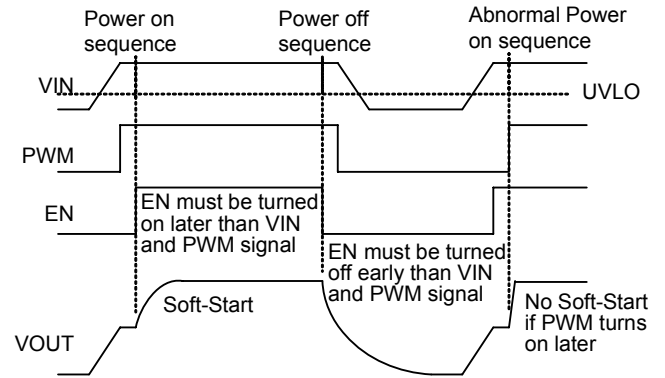

Figure 6. Power On Sequence Control by EN

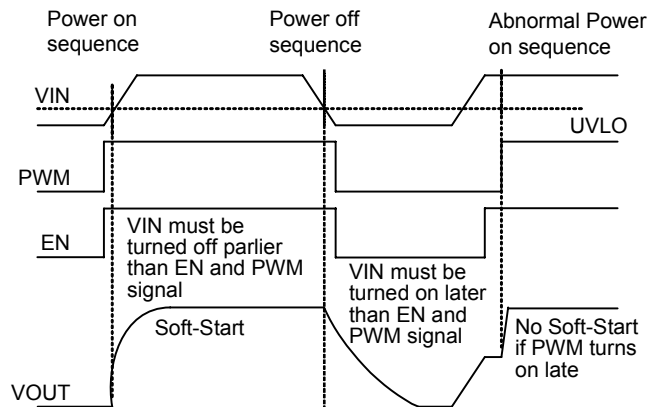

Figure 7. Power On Sequence Control by VIN

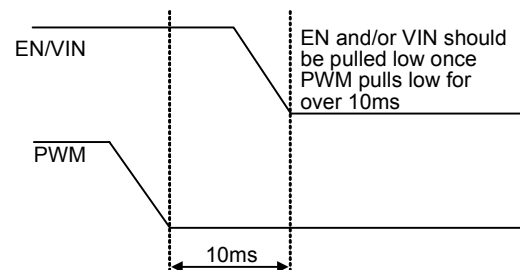

Figure 8. To Prevent "Hard-Start" Sequence

Soft-Start

The soft-start of the RT8573 can be achieved by connecting a capacitor from the SS pin to GND. The built-in soft-start circuit reduces the start-up current spike and output voltage overshoot. The soft-start time is determined by the external capacitor charged by an internal $6\mu\text{A}$ constant charging current. The SS pin directly limits the rate of voltage rise on the VC pin, which in turn limits the peak switch current.

The soft-start interval is set by the soft-start capacitor selection according to the equation :

$$t_{\text{SS}} = C_{\text{SS}} \times \frac{2.4\text{V}}{6\mu\text{A}} \quad (\text{s})$$

A typical value for the soft-start capacitor is $0.1\mu\text{F}$. The soft-start pin reduces the oscillator frequency and the maximum current in the switch. The soft-start capacitor is discharged when EN/UVLO falls below its threshold during an over-temperature event or during a GBIAS under-voltage event.

GBIAS Regulator Operation

The GBIAS pin requires a capacitor for stable operation and to store the charge for the large GATE switching currents. Choose a 10V rated low ESR, X7R or X5R ceramic capacitor for best performance. The value of the capacitor is determined primarily by the stability of the regulator rather than the gate charge of the switching N-MOSFET. A $1\mu\text{F}$ capacitor will be adequate for most applications.

Place the capacitor close to the IC to minimize the trace length to the GBIAS pin and also to the IC ground. An internal current limit on the GBIAS protects the RT8573 from excessive on-chip power dissipation.

If the input voltage, V_{IN} , is less than 8V, then the GBIAS pin should be connected to the input supply. Be aware that if GBIAS supply is used to drive extra circuits besides RT8573, typically the extra GBIAS load should be limited to less than 10mA.

Loop Compensation

The RT8573 uses an internal error amplifier via the compensation pin (VC) to optimize the loop response for specific application. The external inductor, output capacitor,

and compensation resistor and capacitor determine the loop stability. The inductor and output capacitor are chosen based on performance, size and cost. The compensation resistor and capacitor at VC are selected to optimize control loop response and stability.

An external resistor in series with a capacitor is connected from the VC pin to GND to provide a pole and a zero for proper loop compensation. The typical compensation for the RT8573 is $1.8\text{k}\Omega$ and 10nF .

LED Current Setting

The maximum current is programmed by placing an appropriate valued sense resistor at the LED string. When the voltage of ACTL is higher than 1.25V, the LED current can be calculated by the following equation :

$$I_{\text{LED(MAX)}} = \frac{190\text{mV}}{R_{\text{SENSE}}} \quad (\text{mA})$$

where R_{SENSE} is the resistor between the external regulating N-MOSFET and GND.

The ACTL pin should be tied to a voltage higher than 1.25V to get the full-scale 190mV (typical) threshold across the sense resistor. The ACTL pin can also be used to dim the LED current to zero, although relative accuracy decreases with the decreasing voltage sense threshold. When the ACTL pin voltage is less than 1.25V, the LED current is :

$$I_{\text{LED}} = \frac{(V_{\text{ACTL}} - 0.25) \times 190\text{mV}}{R_{\text{SENSE}}} \quad (\text{mA})$$

The ACTL pin can also be connected with a thermistor to provide over temperature protection for the LED load, or with a resistive voltage divider to V_{IN} to reduce output power and switching current when V_{IN} is low.

Brightness Control

For LED applications where a wide dimming range is required, two competing methods are available: analog dimming and PWM dimming. The easiest method is to simply vary the DC current through the LED by analog dimming.

The RT8573 features both analog and digital dimming control. Analog dimming is linearly controlled by an external voltage (0.25V to 1.25V) at the ACTL pin. Digital dimming can be implemented by driving a PWM signal at the DCTL pin for linear current regulator. A very high

contrast ratio can be obtained via true digital PWM dimming, which is achieved by driving ACTL pin with a PWM signal. The recommended PWM frequency range is 100Hz to 10kHz.

Dimming frequency can be sufficiently adjusted from 100Hz to 30kHz. However, LED current cannot be 100% proportional to duty cycle especially for high frequency and low duty ratio because of physical limitation caused by internal switching frequency.

Typically, in order to avoid visible flicker, PWM dimming signal should be greater than 120Hz. Assuming inductor and capacitor sizing close to discontinuous operation, two f_{OSC} cycles are sufficient for proper PWM operation. Thus, the minimum dimming duty can be as low as 1% for the frequency range from 100Hz to 300Hz. For the dimming frequency from 300Hz to 1kHz, the duty is about 5%. If the frequency is increased to 1kHz to 30kHz, the duty will be about 10%.

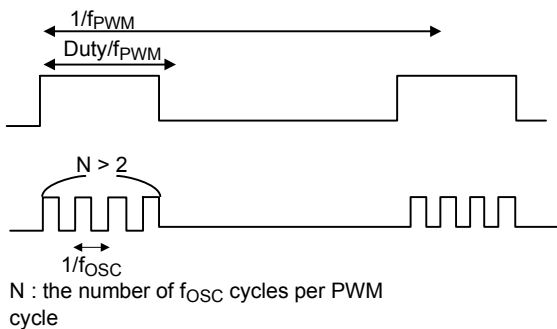

Figure 9. PWM Dimming Parameters

Programmable Switching Frequency

The RSET frequency adjust pin allows the user to program the switching frequency from 100kHz to 1MHz for optimized efficiency and performance or external component size. Higher frequency operation allows for smaller component size but increases switching losses and gate driving current, and may not allow sufficiently high or low duty cycle operation. Lower frequency operation gives better performance but with larger external component size. For an appropriate R_{RSET} resistor value see Table 1 or Figure 10. An external resistor from the RSET pin to GND is required-do not leave this pin open.

Table 1. Switching Frequency vs RT Value (1% Resistors)

f_{OSC} (kHz)	R_{RSET} (k Ω)
800	10.6
600	15.81
500	20.26
300	35.8
200	47.6

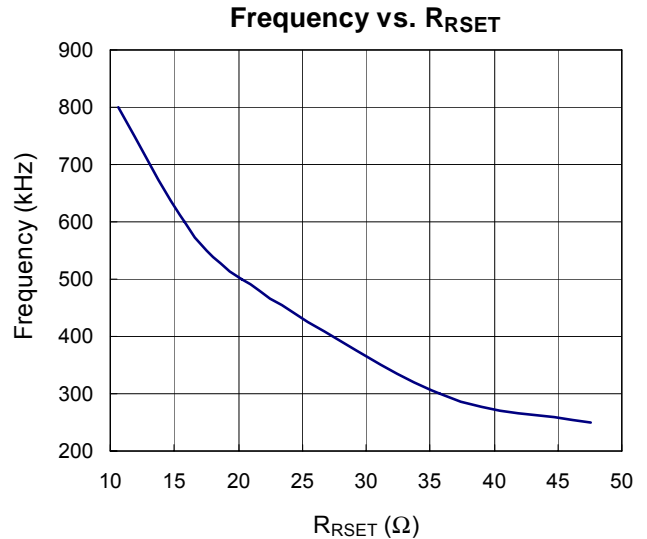

Figure 10. Switching Frequency vs R_{RSET}

Input Over Current Protection

The resistor, R_{SW} , between the source of the external switching N-MOSFET and GND should be selected to provide adequate switch current.

The RT8573 senses the inductor current through ISW pin in the switch on period. The duty cycle depends on the current sense signal summed with the internal slope compensation and compared to the VC pin signal. The external N-MOSFET will be turned off when the current signal is larger than the VC pin signal. In the off period, the inductor current will descend. The external N-MOSFET is turned on by the oscillator at the beginning of the next cycle. To drive the application without exceeding the 90mV (typical) current limit threshold on the ISW pin of the RT8573, it is recommended to select a resistor that gives a switch current of at least 20% greater than the required LED current according to :

$$R_{SW} = \left(\frac{V_{IN} \times 0.1V}{V_{OUT} \times I_{OUT}} \right) [\Omega]$$

The ISW pin input to the RT8573 should be a Kelvin connection to the positive terminal of R_{SW} .

Output Over Voltage Protection Setting

The RT8573 is equipped with an Over Voltage Protection (OVP) function. When the voltage at the OVP pin exceeds a threshold of approximately 1.18V, the power switch will be turned off. The power switch can be turned on again once the voltage at the OVP pin drops below 1.18V. The output voltage could be clamped at a certain voltage level set by the following equation :

$$V_{OUT, OVP} = 1.18 \times \left(1 + \frac{R1}{R2}\right)$$

where R1 and R2 are the voltage divider resistors from V_{OUT} to GND with the divider center node connected to the OVP pin

If at least one string is in normal operation, the controller will automatically ignore the open strings and continue to regulate the current for the string(s) in normal operation.

Over Temperature Protection

The RT8573 provides an Over Temperature Protection (OTP) function to prevent the excessive power dissipation from overheating the device. The OTP function will shut down switching operation when the die junction temperature exceeds 145°C. The chip will automatically start to switch again when the die junction temperature is reduced by approximately 10°C.

Inductor Selection

The inductor used with the RT8573 should have a saturation current rating appropriate to the maximum switch current. Choose an inductor value based on operating frequency, input and output voltage to provide a current mode ramp of approximately 20mV magnitude on the ISW pin during the switch on-time. The following equations are useful to estimate the inductor value :

$$L = \frac{(V_{OUT} - V_{IN}) \times (V_{IN})^2}{2 \times I_{OUT} \times f \times (V_{OUT})^2}$$

where,

V_{OUT} = Maximum output voltage.

V_{IN} = Minimum input voltage.

f = Operating frequency.

I_{OUT} = Sum of current from all LED strings.

η is the efficiency of the power converter.

Power MOSFET Selection

For applications operating at high input or output voltages, the power N-MOSFET switch is typically chosen for drain voltage, V_{DS} , rating and low gate charge. Consideration of switch on-resistance, $R_{DS(ON)}$, is usually secondary because switching losses dominate power loss. The GBIAS regulator on the RT8573 has a fixed current limit to protect the IC from excessive power dissipation at high V_{IN} , so the N-MOSFET should be chosen such that the product of Qg at 5V and switching frequency does not exceed the GBIAS current limit.

Schottky Diode Selection

The Schottky diode, with their low forward voltage drop and fast switching speed, is necessary for RT8573 applications. In addition, power dissipation, reverse voltage rating and pulsating peak current are also important parameters for Schottky diode selection. Choose a suitable Schottky diode with reverse voltage rating greater than the maximum output voltage. The diode's average current rating must exceed the average output current. The diode conducts current only when the power switch is turned off (typically less than 50% duty cycle). If using the PWM feature for dimming, it is important to consider diode leakage, which increases with temperature, from the output during the PWM low interval. Therefore, a Schottky diode with sufficiently low leakage current is suggested.

$$I_{D, PEAK} = 1.2 \times I_{OUT} \times \left(\frac{V_{OUT} - V_{IN}}{V_{OUT}}\right)$$

Capacitor Selection

The input capacitor reduces current spikes from the input supply and minimizes noise injection to the converter. For most of the RT8573 applications, a 10 μ F ceramic capacitor is sufficient. A value higher or lower may be used depending on the noise level from the input supply and the input current to the converter.

In Boost Application, the output capacitor is typically a ceramic capacitor and is selected based on the output voltage ripple requirements. The minimum value of the output capacitor, C_{OUT} , is approximately given by the following equation :

$$C_{OUT} = \frac{I_{OUT} \times (V_{OUT} - V_{IN})}{\eta \times V_{RIPPLE} \times V_{OUT} \times f}$$

For LED applications, the equivalent resistance of the LED is typically low and the output filter capacitor should be sized to attenuate the current ripple. Use of X7R type ceramic capacitors is recommended. Lower operating frequencies will require proportionately higher capacitor values.

Thermal Considerations

For continuous operation, do not exceed absolute maximum junction temperature. The maximum power dissipation depends on the thermal resistance of the IC package, PCB layout, rate of surrounding airflow, and difference between junction and ambient temperature. The maximum power dissipation can be calculated by the following formula :

$$P_{D(MAX)} = (T_{J(MAX)} - T_A) / \theta_{JA}$$

where $T_{J(MAX)}$ is the maximum junction temperature, T_A is the ambient temperature, and θ_{JA} is the junction to ambient thermal resistance.

For recommended operating condition specifications of the RT8573, the maximum junction temperature is 125°C and T_A is the ambient temperature. The junction to ambient thermal resistance, θ_{JA} , is layout dependent. For SOP-16 packages, the thermal resistance, θ_{JA} , is 85°C/W on a standard JEDEC 51-7 single-layer thermal test board. The maximum power dissipation at $T_A = 25^\circ\text{C}$ can be calculated by the following formula :

$$P_{D(MAX)} = (125^\circ\text{C} - 25^\circ\text{C}) / (85^\circ\text{C/W}) = 1.176\text{W for SOP-16 package}$$

The maximum power dissipation depends on the operating ambient temperature for fixed $T_{J(MAX)}$ and thermal resistance, θ_{JA} . For the RT8573 package, the derating curve in Figure 11 allows the designer to see the effect of rising ambient temperature on the maximum power dissipation.

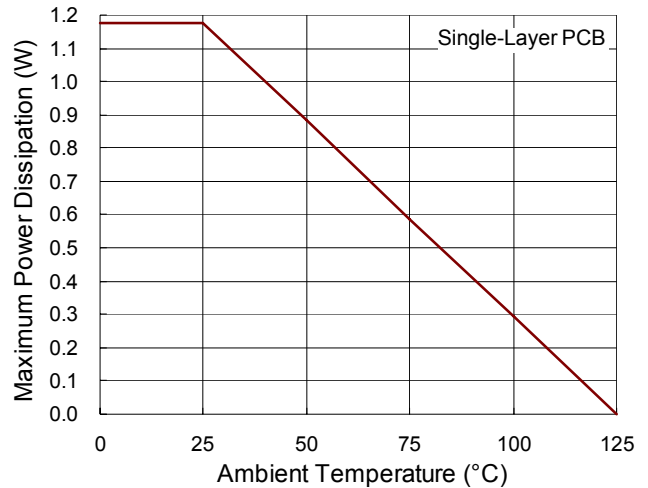

Figure 11. Derating Curve for RT8573 Package

Layout Consideration

PCB layout is very important when designing power switching converter circuits. Some recommended layout guidelines are suggested as follows :

- ▶ The power components L1, D1, C_{IN}, M1 and C_{OUT} must be placed as close to each other as possible to reduce the ac current loop area. At least one via to the ground plane immediately under the exposed pad. The ground trace on the top layer of the PC board should be as wide and short as possible to minimize series resistance and inductance.
- ▶ Place L1 and D1 connected to N-MOSFET as close to each other as possible. The trace should be as short and wide as possible.
- ▶ The input capacitor, C_{IN}, must be placed as close to the VCC pin as possible.
- ▶ Place the compensation components as close to the VC pin as possible to avoid noise pick up.

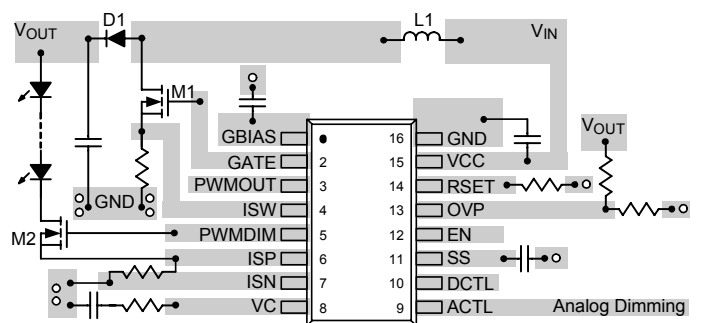
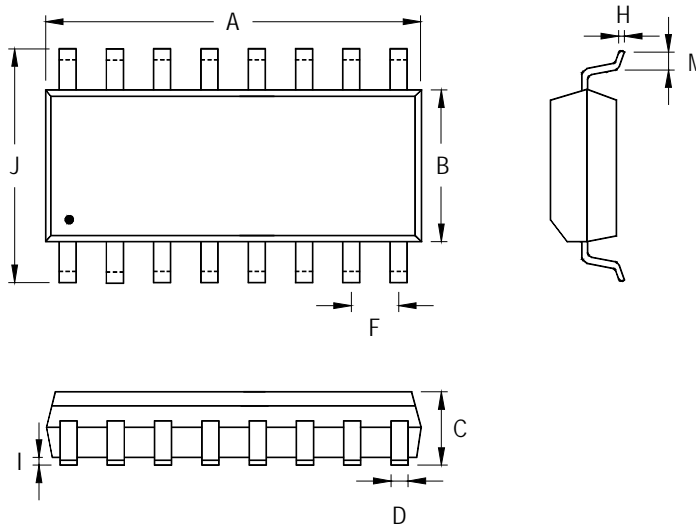

Figure 12. PCB Layout Guide

Outline Dimension



Symbol	Dimensions In Millimeters		Dimensions In Inches	
	Min	Max	Min	Max
A	9.804	10.008	0.386	0.394
B	3.810	3.988	0.150	0.157
C	1.346	1.753	0.053	0.069
D	0.330	0.508	0.013	0.020
F	1.194	1.346	0.047	0.053
H	0.178	0.254	0.007	0.010
I	0.102	0.254	0.004	0.010
J	5.791	6.198	0.228	0.244
M	0.406	1.270	0.016	0.050

16-Lead SOP Plastic Package

Richtek Technology Corporation

Headquarter
 5F, No. 20, Taiyuen Street, Chupei City
 Hsinchu, Taiwan, R.O.C.
 Tel: (8863)5526789 Fax: (8863)5526611

Richtek Technology Corporation

Taipei Office (Marketing)
 8F, No. 137, Lane 235, Paochiao Road, Hsintien City
 Taipei County, Taiwan, R.O.C.
 Tel: (8862)89191466 Fax: (8862)89191465
 Email: marketing@richtek.com

Information that is provided by Richtek Technology Corporation is believed to be accurate and reliable. Richtek reserves the right to make any change in circuit design, specification or other related things if necessary without notice at any time. No third party intellectual property infringement of the applications should be guaranteed by users when integrating Richtek products into any application. No legal responsibility for any said applications is assumed by Richtek.

Datasheet Revision History

Version	Date	Page No.	Item	Description
P00	2010/8/17			First edition