

# LM2601

*LM2601 Adapter Interface Circuit*



Literature Number: SNVS079B

## Adapter Interface Circuit

### General Description

The Adapter Interface Circuit (AIC) is used to sense the presence of an external power source for a portable computer. It notifies the computer if a source is present and indicates if the source is appropriate for charging battery packs inside the computer. The AIC also senses an adapter current and its direction. AIC isolates the adapter and signals the computer when peak current threshold is exceeded.

LM2601 drives P-channel FETs. No high current rated Schottky diode is required to implement an adapter switchover circuit. This significantly decreases additional heat dissipation during simultaneous fast battery charging while running a computer, particularly in Maximum Performance mode of operation

### Features

- Detects an AC-DC adapter suitable for battery charging or an airplane or car power line adapter that should not be used for battery charging
- Allows the implementation of intelligent switchover circuits for portable systems

- LM2601 shuts down automatically when adapter is removed
- Low leakage current from battery when not powered
- Drives P-channel FETs, no Schottky diodes are required
- No reverse inrush current from battery into the adapter output capacitance
- Allows for battery capacity gas-gauge calibration under system software/firmware control
- Adapter over current threshold programmable with external resistors
- Wide input range: 5V - 24V
- Available in TSSOP-14 package

### Applications

- Portable Computers
- Portable IAs (Internet Appliances, Information Appliances)
- Other Battery Powered Devices

### Block Diagram

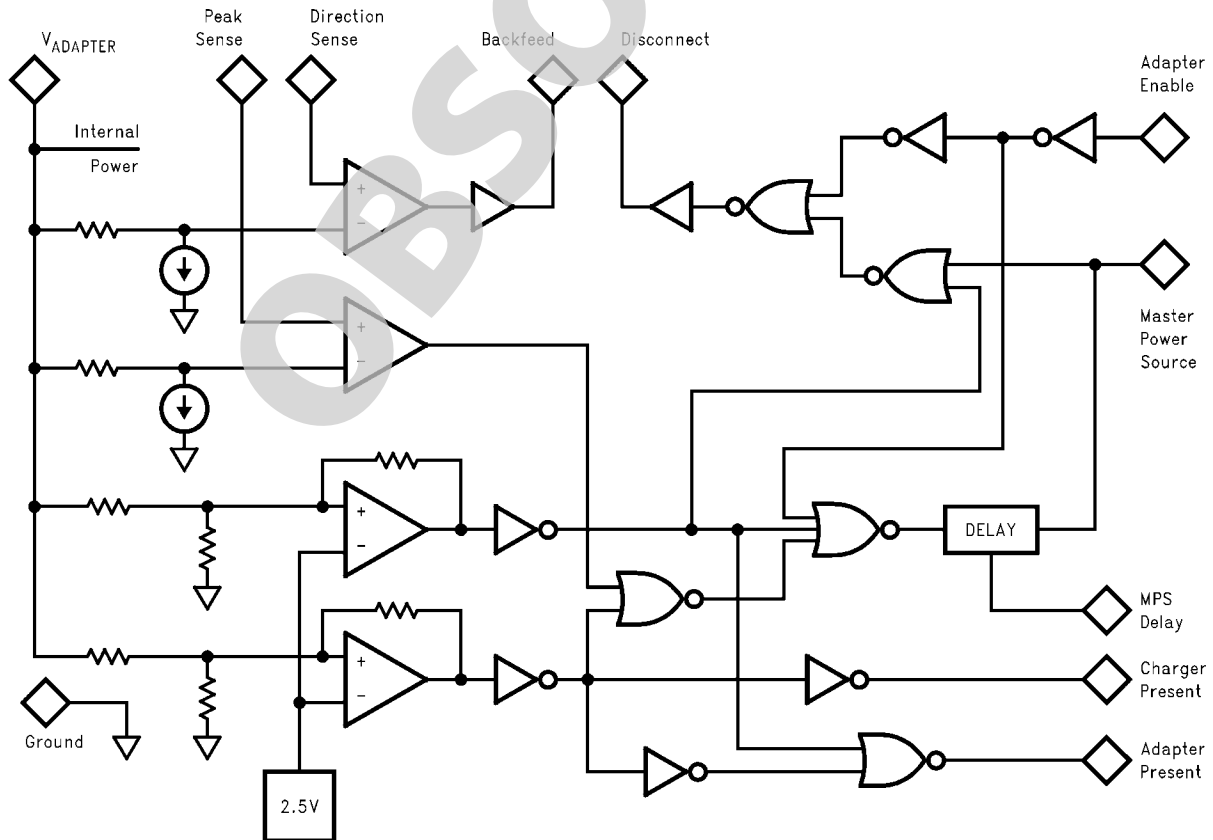

10130901

## Pin Configuration

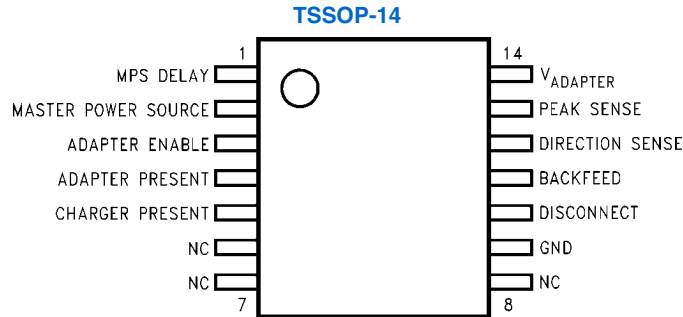

10130902

## Ordering Information

| Order Number | Package Number | Package Type | Supplied As*                    |
|--------------|----------------|--------------|---------------------------------|
| LM2601MTC    | MTC14          | TSSOP-14     | Rail (94 Units/Rail)            |
| LM2601MTCX   | MTC14          | TSSOP-14     | Tape and Reel (2500 Units/Reel) |

\* Partial Rails are available, there is no minimum order quantity. Tape and Reel is supplied as full reels only.

## Pin Description

| Pin No. | Name                 | Function  |
|---------|----------------------|---|
| 1       | MPS DELAY            | A capacitor between this pin and ground sets the delay of the MPS risetime. See MPS DELAY description in Typical Application section.   |
| 2       | MASTER POWER SOURCE  | Bi-directional logic pin. If driven high by an external source, indicates that a battery is powering the power bus. If driven high by the AIC, indicates the adapter is powering the bus. AIC cannot drive MPS low. If there is no valid adapter voltage present, the pin is not an output but a high impedance logic input. The input is pulled-down via an internal 40k resistor. |
| 3       | ADAPTER ENABLE       | Logic input pin. Active high. Grants permission to the adapter to drive both the power bus and the MPS signal.  |
| 4       | ADAPTER PRESENT      | Logic output pin. High when $12 \text{ volts} < V_{\text{ADAPTER}} < 17 \text{ volts}$ . The output typically has 40k pull-down resistor. The source current is not internally limited and the part can be damaged if the output is shorted to ground when driven HIGH.   |
| 5       | CHARGER PRESENT      | Logic output pin. High when $V_{\text{ADAPTER}} > 17 \text{ volts}$ . The output typically has 40k pull-down resistor. The source current is not internally limited and the part can be damaged if the output is shorted to ground when driven HIGH.  |
| 9       | GND                  | IC ground pin.  |
| 10      | DISCONNECT           | Drives the gate of the disconnect P-ch FET.   |
| 11      | BACKFEED             | Drives the gate of the backfeed P-ch FET.   |
| 12      | DIRECTION SENSE      | Connection for current sense resistor to control BACKFEED.  |
| 13      | PEAK SENSE           | Connection for current sense resistor to control DISCONNECT.  |
| 14      | $V_{\text{ADAPTER}}$ | Power input pin. Output of AC adapter, auto adapter or airline adapter.   |

## Absolute Maximum Ratings *(Note 1)*

If Military/Aerospace specified devices are required, please contact the National Semiconductor Sales Office/Distributors for availability and specifications.

|   |                        |
|---|------------------------|
| $V_{ADAPTER}$   | -0.3V to 28V           |
| $V_{PEAK\ SENSE}, V_{DIRECTION\ SENSE}, V_{BACKFEED}, V_{DISCONNECT}$ | -0.3V to $V_{ADAPTER}$ |
| $V_{ADAPTER\ ENABLE}, V_{MASTER\ POWER\ SOURCE}$                      | -0.3V to 5.5V          |
| $V_{MPS\ DELAY}$  | -0.3V to 2V            |

|                                  |                |
|----------------------------------|----------------|
| Storage Temperature              | -40°C to 125°C |
| ESD Ratings                      |                |
| Human Body Model <i>(Note 2)</i> | 2kV            |
| Machine Model <i>(Note 3)</i>    | 200V           |

## Operating Ratings *(Note 1)*

|                                  |               |
|----------------------------------|---------------|
| Supply Voltage ( $V_{ADAPTER}$ ) | 5V to 24V     |
| Ambient Temp. Range              | -20°C to 70°C |
| Junction Temp. Range             | -20°C to 85°C |

## Electrical Characteristics

Limits with standard typeface apply for  $T_J = 25^\circ\text{C}$ , and limits in **boldface type** apply over the full temperature range *(Note 4)*

| Symbol                  | Parameter  | Conditions   | Min               | Typ  | Max               | Units         |
|-------------------------|--|--|-------------------|--|-------------------|---------------|
| $V_{AE}$                | Adapter Enable -<br>3V- or 5V-CMOS or TTL Logic Input                      | High<br>Low  | <b>2.0</b>        |  | <b>0.8</b>        | V             |
| $V_{AP, CP}$            | Logic Output Voltage<br>Adapter present, Charger present                   | High<br>Low, $I_{SINK} = 5\mu\text{A}$                                   | <b>2.9</b>        | 3.1<br>0.25  | <b>0.6</b>        | V             |
| $V_{MPS_I}$             | Master Power Source<br>5V-CMOS Logic Input                                 | High<br>Low  | <b>4.0</b>        |  | <b>0.8</b>        | V             |
| $V_{MPS_O}$             | Logic Output Voltage<br>Master Power Source                                | $V_{ADAPTER} > 5.8\text{V}$<br>High<br>Low                               | <b>4.5</b>        | 4.75<br>0.05   | <b>0.5</b>        | V             |
| $V_{ADAPTER}$           | Adapter Voltage for $V_{AP}$ Low-to-High<br>Transition                     |  | <b>11.7</b>       | 12.0   | <b>12.3</b>       | V             |
|                         | Hysteresis   |  | <b>1.8</b>        | 2.0  | <b>2.2</b>        |               |
| $V_{CHARGER}$           | Adapter Voltage for $V_{CP}$<br>Low-to-High Transition                     |  | <b>16.5</b>       | 17.0   | <b>17.4</b>       | V             |
|                         | Hysteresis   |  | <b>0.08</b>       | 0.10   | <b>0.12</b>       |               |
| $\Delta V_{BACKFEED}$   | Current Sense Differential Voltage<br>Threshold for Driving Backfeed FET   | $V_{ADAPTER}$ - Direction sense,<br>$V_{ADAPTER} = 5\text{V}$            | 4<br><b>3</b>     | 9  | 17<br><b>18</b>   | mV            |
| $\Delta V_{DISCONNECT}$ | Current Sense Differential Voltage<br>Threshold for Driving Disconnect FET | $V_{ADAPTER}$ - Peak sense,<br>$V_{ADAPTER} = 24\text{V}$                | 127<br><b>125</b> | 135  | 143<br><b>145</b> | mV            |
| $V_{BACKFEED}$          | FET Control Voltage  | $V_{ADAPTER} > 11\text{V}$<br>High                                       |                   | $V_{ADAPTER} - 0.5\text{V}$  |                   | V             |
| $V_{DISCONNECT}$        |  | $V_{ADAPTER} > 11\text{V}$<br>Low  |                   | $V_{ADAPTER} - 10\text{V or GND} + 0.5\text{V},$<br>whichever is greater |                   | V             |
| $t_{DRIVE}$             | Rise/Fall Time of FET Drive<br><i>(Note 5)</i>                             | $V_{ADAPTER} = 10\text{V}$<br>$C_{Load} = 3000\text{pF}$                 |                   | 3  | <b>6</b>          | $\mu\text{s}$ |
| $I_Q$                   | Quiescent Current  | $V_{ADAPTER} = 24\text{V}$   |                   | 2  | <b>10</b>         | mA            |
| $I_{L,B}, I_{L,D}$      | Leakage Current into Backfeed or<br>Disconnect                             | $V_{ADAPTER} = 0\text{V}$<br>$V_{BACKFEED}, V_{DISCONNECT} = 18\text{V}$ |                   | 1  | <b>15</b>         | $\mu\text{A}$ |
| $I_{L,AE}$              | Input Current into Adapter Enable Input                                    | $V_{AE} = 3.3\text{V},$<br>Backfeed/Disconnect = 18V                     |                   | 50   |                   | $\mu\text{A}$ |
| $I_{L,MPS}$             | Input Current into MPS Input   | $V_{MPS} = 5.5\text{V}$  |                   | 175  |                   | $\mu\text{A}$ |
| $TC_{DELAY}$            | Delay Time Temperature Coefficient   |  |                   | 4000   |                   | ppm/°C        |

**Note 1:** Absolute Maximum Ratings indicate limits beyond which damage to the device may occur. Operating Ratings indicate conditions for which the device is intended to be functional, but do not guarantee specific performance limits. For guaranteed specifications and test conditions, see the Electrical Characteristics.

**Note 2:** The human body model is a 100pF capacitor discharged through a 1.5k $\Omega$  resistor into each pin.

**Note 3:** The machine model is a 200pF capacitor discharged directly into each pin. All pins are rated for 200V except pins 4 and 5 which are rated for 100V.

**Note 4:** Datasheet min/max specification limits are guaranteed by design, test, or statistical analysis.

**Note 5:** Adapter Enable input is used to change the state of Disconnect, Direction Sense input is used to change the state of Backfeed.

- Fall time is measured as the time it takes Backfeed or Disconnect voltage to go from a high level (approx.  $V_{ADAPTER} - 0.5V$ ) to  $(V_{ADAPTER} - 4V)$  after the signal is initiated at Adapter Enable or Direction Sense.
- Rise time is measured as the time it takes Backfeed or Disconnect voltage to go from a low level (approx.  $0.5V$ ) to  $(V_{ADAPTER} - 2V)$  after the signal is initiated at Adapter Enable or Direction Sense.

## Typical Application

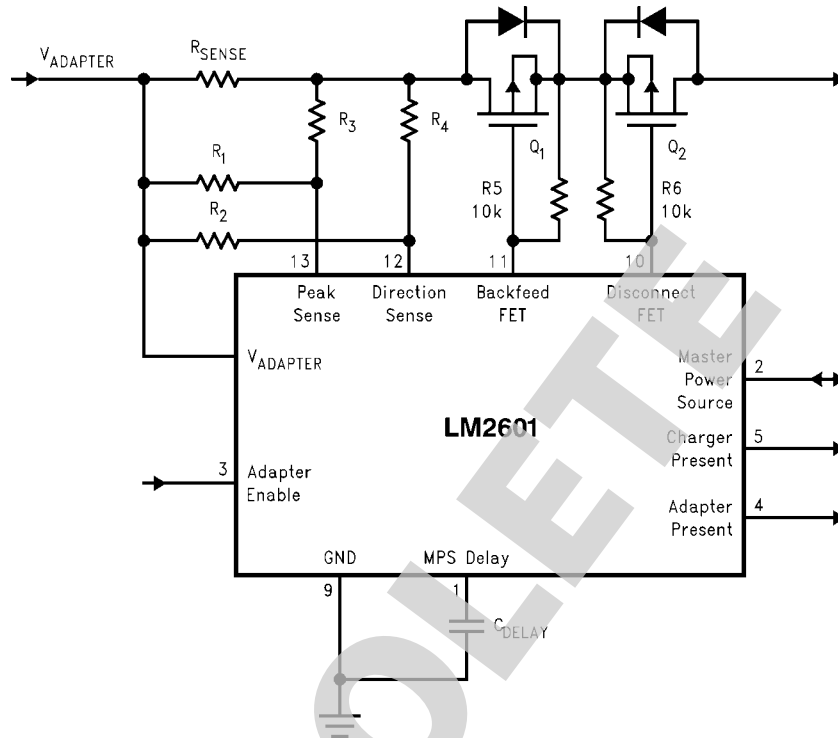

### Notes

- $R_{SENSE}$  value should be selected to guarantee that a programmed over current will cause a voltage drop across  $R_{SENSE}$  of approx. 135mV. If a higher value of  $R_{SENSE}$  has to be selected then  $R1/R3$  resistor divider should be used to scale the voltage drop down.
- Internal and external circuits associated with Direction Sense and Backfeed FET pins allow to emulate a Schottky diode functionality with much lower forward voltage drop and, therefore, with much lower power dissipation.  $R2/R4$  resistor divider programs the backfeed current protection threshold. The backfeed FET Q1 turns off when the backfeed current pulse level causes more than 9 mV (typical value) voltage drop between  $V_{adapter}$  pin and Direction Sense pin.
- Voltage difference ( $V_{DIRECTION\ SENSE} - V_{ADAPTER}$ ) must be higher than 20mV to reliably isolate the adapter in case of leakage.
- R5 and R6 prevent the FETs from turning on unless driven by LM2601.
- $C_{DELAY}$  value can be calculated from the following formula:  

$$C_{DELAY}(\text{nF}) = T_{DELAY}(\mu\text{s})/90 \text{ at } 25^{\circ}\text{C}$$
- $T_{DELAY}$  temperature coefficient equals 4000ppm/°C. See also the Typical Delay Time vs. Temperature graph.
- Pin Master Power Source (MPS) should be connected to System Management Controller's (SMC) and battery packs' GPIOs. When SMC detects a powered AC adapter via active signals at Charger Present or Adapter Present outputs, it asserts Adapter Enable signal and isolates the battery pack(s). Adapter Enable signal turns the Disconnect FET on. When the AC adapter is unplugged or powered off, SMC enables one of the system battery packs. The battery packs' embedded controller starts driving the logic MPS signal high that turns the Disconnect FET off.

10130903

Typical Delay Time vs. Temperature

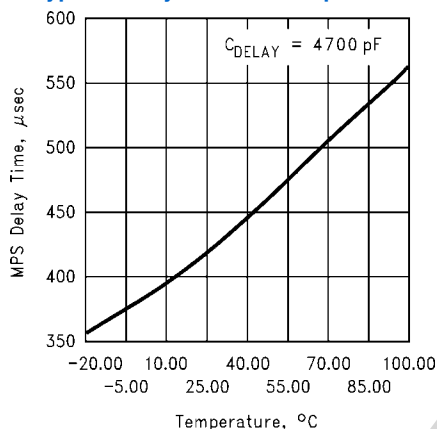

10130905

## Application Information

The adapter interface circuit (AIC) IC provides the control functions necessary for use in mating a constant voltage output AC-DC adapter or airline adapter to a notebook computer system or a portable device. It allows optimal battery charging during computer operation, and allows battery discharge for battery gas gauge calibration. It receives control signals from the notebook computer, monitors input current from the adapter, provides adapter voltage status to the notebook system management microcontroller (or "embedded controller"), and appropriately drives MOSFET switches to electrically connect the adapter to the computer.

AIC will allow a system designer to solve various power management tasks typical for an adapter powered systems containing a rechargeable battery.

When a notebook computer is being powered from a battery and the adapter is plugged in, the computer should start drawing power from the adapter, not from the battery. The most time efficient charging scenario is when a computer draws the full rated current from a constant voltage adapter. The computer uses what it needs to run, and passes all remaining power on to the battery for charging. The computer should be able to automatically refuse to charge a battery when powered from an airplane power line. It may be neces-

sary sometimes to have a computer fully discharging the battery and then fully recharging it (for battery gas gauge calibration purposes) while being powered by an AC adapter.

AIC will also allow a computer to prevent backfeeding current into an adapter if the adapter is not powered while being plugged into the computer (some of existing adapters can draw current from the computer under this conditions for charging the AC adapter output bulk capacitance from the computer battery).

While the lowest usable adapter voltage is about 9.5V, that is  $V_{ADAPTER} = 11.7V$  minus 2.2V hysteresis, AIC is operational down to  $V_{ADAPTER} = 5V$ . This means that AIC will not generate false readings down to  $V_{ADAPTER} = 5V$ . Such false readings would be MPS = HIGH, ADAPTER PRESENT = HIGH, CHARGER PRESENT = HIGH.

AIC determines usable voltage ranges by comparing  $V_{ADAPTER}$  with an internal 2.5V voltage reference (see also Electrical Characteristics). AIC detects operating current limit and leakage current limit into the adapter jack by differential sensing across current sense resistor  $R_{SENSE}$  either directly or scaled down by resistor dividers R1/R3 and R2/R4.

When designing the LM2601 into a system it may be necessary to consider ESD protection requirements for the adapter jack according to your system design spec.

**Physical Dimensions** inches (millimeters) unless otherwise noted

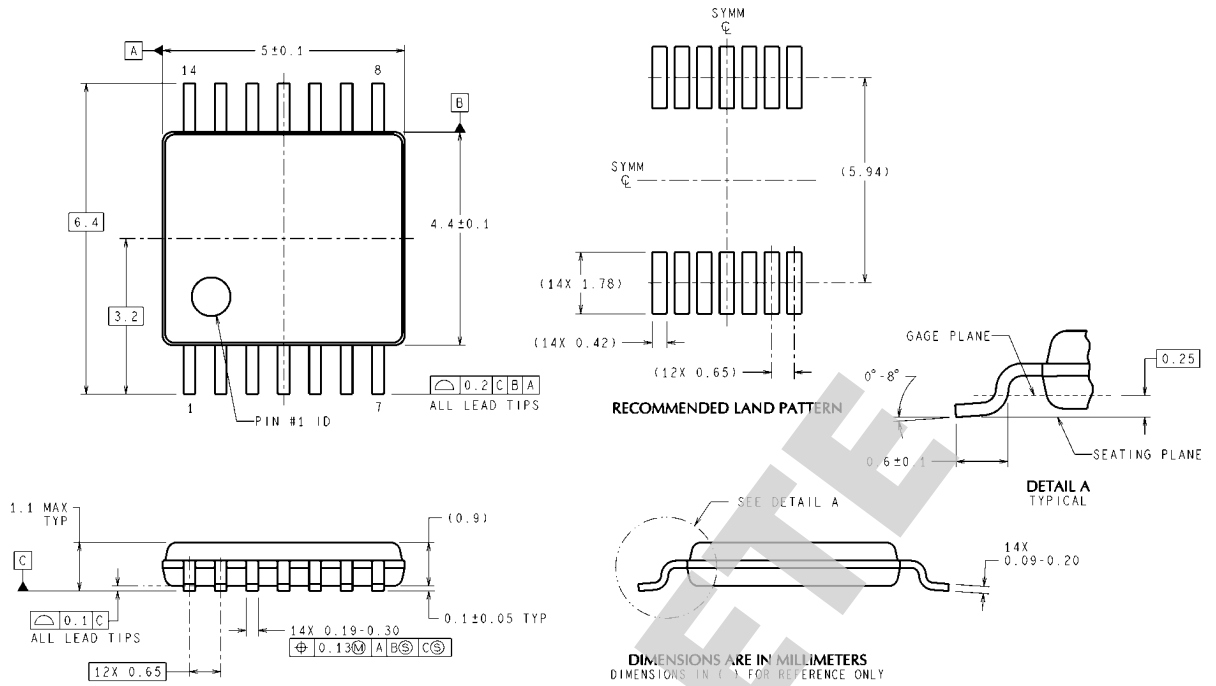

**TSSOP-14 Package**  
**14-Lead Thin Shrink Small-Outline Package**  
**For Ordering, Refer to Ordering Information Table**  
**NS Package Number MTC14**

MTC14 (Rev D)

OBSOLETE

# Notes

LM2601

**OBSOLETE**



## Notes

For more National Semiconductor product information and proven design tools, visit the following Web sites at:  
[www.national.com](http://www.national.com)

| Products                       |  | Design Support               |  |
|--------------------------------|--|------------------------------|--|
| Amplifiers                     | <a href="http://www.national.com/amplifiers">www.national.com/amplifiers</a> | WEBENCH® Tools               | <a href="http://www.national.com/webench">www.national.com/webench</a>             |
| Audio                          | <a href="http://www.national.com/audio">www.national.com/audio</a>           | App Notes                    | <a href="http://www.national.com/appnotes">www.national.com/appnotes</a>           |
| Clock and Timing               | <a href="http://www.national.com/timing">www.national.com/timing</a>         | Reference Designs            | <a href="http://www.national.com/refdesigns">www.national.com/refdesigns</a>       |
| Data Converters                | <a href="http://www.national.com/adc">www.national.com/adc</a>               | Samples                      | <a href="http://www.national.com/samples">www.national.com/samples</a>             |
| Interface                      | <a href="http://www.national.com/interface">www.national.com/interface</a>   | Eval Boards                  | <a href="http://www.national.com/evalboards">www.national.com/evalboards</a>       |
| LVDS                           | <a href="http://www.national.com/lvds">www.national.com/lvds</a>             | Packaging                    | <a href="http://www.national.com/packaging">www.national.com/packaging</a>         |
| Power Management               | <a href="http://www.national.com/power">www.national.com/power</a>           | Green Compliance             | <a href="http://www.national.com/quality/green">www.national.com/quality/green</a> |
| Switching Regulators           | <a href="http://www.national.com/switchers">www.national.com/switchers</a>   | Distributors                 | <a href="http://www.national.com/contacts">www.national.com/contacts</a>           |
| LDOs                           | <a href="http://www.national.com/ldo">www.national.com/ldo</a>               | Quality and Reliability      | <a href="http://www.national.com/quality">www.national.com/quality</a>             |
| LED Lighting                   | <a href="http://www.national.com/led">www.national.com/led</a>               | Feedback/Support             | <a href="http://www.national.com/feedback">www.national.com/feedback</a>           |
| Voltage References             | <a href="http://www.national.com/vref">www.national.com/vref</a>             | Design Made Easy             | <a href="http://www.national.com/easy">www.national.com/easy</a>                   |
| PowerWise® Solutions           | <a href="http://www.national.com/powerwise">www.national.com/powerwise</a>   | Applications & Markets       | <a href="http://www.national.com/solutions">www.national.com/solutions</a>         |
| Serial Digital Interface (SDI) | <a href="http://www.national.com/sdi">www.national.com/sdi</a>               | Mil/Aero                     | <a href="http://www.national.com/milaero">www.national.com/milaero</a>             |
| Temperature Sensors            | <a href="http://www.national.com/tempensors">www.national.com/tempensors</a> | SolarMagic™                  | <a href="http://www.national.com/solarmagic">www.national.com/solarmagic</a>       |
| PLL/VCO                        | <a href="http://www.national.com/wireless">www.national.com/wireless</a>     | PowerWise® Design University | <a href="http://www.national.com/training">www.national.com/training</a>           |

THE CONTENTS OF THIS DOCUMENT ARE PROVIDED IN CONNECTION WITH NATIONAL SEMICONDUCTOR CORPORATION ("NATIONAL") PRODUCTS. NATIONAL MAKES NO REPRESENTATIONS OR WARRANTIES WITH RESPECT TO THE ACCURACY OR COMPLETENESS OF THE CONTENTS OF THIS PUBLICATION AND RESERVES THE RIGHT TO MAKE CHANGES TO SPECIFICATIONS AND PRODUCT DESCRIPTIONS AT ANY TIME WITHOUT NOTICE. NO LICENSE, WHETHER EXPRESS, IMPLIED, ARISING BY ESTOPPEL OR OTHERWISE, TO ANY INTELLECTUAL PROPERTY RIGHTS IS GRANTED BY THIS DOCUMENT.

TESTING AND OTHER QUALITY CONTROLS ARE USED TO THE EXTENT NATIONAL DEEMS NECESSARY TO SUPPORT NATIONAL'S PRODUCT WARRANTY. EXCEPT WHERE MANDATED BY GOVERNMENT REQUIREMENTS, TESTING OF ALL PARAMETERS OF EACH PRODUCT IS NOT NECESSARILY PERFORMED. NATIONAL ASSUMES NO LIABILITY FOR APPLICATIONS ASSISTANCE OR BUYER PRODUCT DESIGN. BUYERS ARE RESPONSIBLE FOR THEIR PRODUCTS AND APPLICATIONS USING NATIONAL COMPONENTS. PRIOR TO USING OR DISTRIBUTING ANY PRODUCTS THAT INCLUDE NATIONAL COMPONENTS, BUYERS SHOULD PROVIDE ADEQUATE DESIGN, TESTING AND OPERATING SAFEGUARDS.

EXCEPT AS PROVIDED IN NATIONAL'S TERMS AND CONDITIONS OF SALE FOR SUCH PRODUCTS, NATIONAL ASSUMES NO LIABILITY WHATSOEVER, AND NATIONAL DISCLAIMS ANY EXPRESS OR IMPLIED WARRANTY RELATING TO THE SALE AND/OR USE OF NATIONAL PRODUCTS INCLUDING LIABILITY OR WARRANTIES RELATING TO FITNESS FOR A PARTICULAR PURPOSE, MERCHANTABILITY, OR INFRINGEMENT OF ANY PATENT, COPYRIGHT OR OTHER INTELLECTUAL PROPERTY RIGHT.

#### LIFE SUPPORT POLICY

**NATIONAL'S PRODUCTS ARE NOT AUTHORIZED FOR USE AS CRITICAL COMPONENTS IN LIFE SUPPORT DEVICES OR SYSTEMS WITHOUT THE EXPRESS PRIOR WRITTEN APPROVAL OF THE CHIEF EXECUTIVE OFFICER AND GENERAL COUNSEL OF NATIONAL SEMICONDUCTOR CORPORATION.** As used herein:

Life support devices or systems are devices which (a) are intended for surgical implant into the body, or (b) support or sustain life and whose failure to perform when properly used in accordance with instructions for use provided in the labeling can be reasonably expected to result in a significant injury to the user. A critical component is any component in a life support device or system whose failure to perform can be reasonably expected to cause the failure of the life support device or system or to affect its safety or effectiveness.

National Semiconductor and the National Semiconductor logo are registered trademarks of National Semiconductor Corporation. All other brand or product names may be trademarks or registered trademarks of their respective holders.

Copyright© 2011 National Semiconductor Corporation

For the most current product information visit us at [www.national.com](http://www.national.com)



[www.national.com](http://www.national.com)

**National Semiconductor  
Americas Technical  
Support Center**  
Email: [support@nsc.com](mailto:support@nsc.com)  
Tel: 1-800-272-9959

**National Semiconductor Europe  
Technical Support Center**  
Email: [europe.support@nsc.com](mailto:europe.support@nsc.com)

**National Semiconductor Asia  
Pacific Technical Support Center**  
Email: [ap.support@nsc.com](mailto:ap.support@nsc.com)

**National Semiconductor Japan  
Technical Support Center**  
Email: [jpn.feedback@nsc.com](mailto:jpn.feedback@nsc.com)

## IMPORTANT NOTICE

Texas Instruments Incorporated and its subsidiaries (TI) reserve the right to make corrections, modifications, enhancements, improvements, and other changes to its products and services at any time and to discontinue any product or service without notice. Customers should obtain the latest relevant information before placing orders and should verify that such information is current and complete. All products are sold subject to TI's terms and conditions of sale supplied at the time of order acknowledgment.

TI warrants performance of its hardware products to the specifications applicable at the time of sale in accordance with TI's standard warranty. Testing and other quality control techniques are used to the extent TI deems necessary to support this warranty. Except where mandated by government requirements, testing of all parameters of each product is not necessarily performed.

TI assumes no liability for applications assistance or customer product design. Customers are responsible for their products and applications using TI components. To minimize the risks associated with customer products and applications, customers should provide adequate design and operating safeguards.

TI does not warrant or represent that any license, either express or implied, is granted under any TI patent right, copyright, mask work right, or other TI intellectual property right relating to any combination, machine, or process in which TI products or services are used. Information published by TI regarding third-party products or services does not constitute a license from TI to use such products or services or a warranty or endorsement thereof. Use of such information may require a license from a third party under the patents or other intellectual property of the third party, or a license from TI under the patents or other intellectual property of TI.

Reproduction of TI information in TI data books or data sheets is permissible only if reproduction is without alteration and is accompanied by all associated warranties, conditions, limitations, and notices. Reproduction of this information with alteration is an unfair and deceptive business practice. TI is not responsible or liable for such altered documentation. Information of third parties may be subject to additional restrictions.

Resale of TI products or services with statements different from or beyond the parameters stated by TI for that product or service voids all express and any implied warranties for the associated TI product or service and is an unfair and deceptive business practice. TI is not responsible or liable for any such statements.

TI products are not authorized for use in safety-critical applications (such as life support) where a failure of the TI product would reasonably be expected to cause severe personal injury or death, unless officers of the parties have executed an agreement specifically governing such use. Buyers represent that they have all necessary expertise in the safety and regulatory ramifications of their applications, and acknowledge and agree that they are solely responsible for all legal, regulatory and safety-related requirements concerning their products and any use of TI products in such safety-critical applications, notwithstanding any applications-related information or support that may be provided by TI. Further, Buyers must fully indemnify TI and its representatives against any damages arising out of the use of TI products in such safety-critical applications.

TI products are neither designed nor intended for use in military/aerospace applications or environments unless the TI products are specifically designated by TI as military-grade or "enhanced plastic." Only products designated by TI as military-grade meet military specifications. Buyers acknowledge and agree that any such use of TI products which TI has not designated as military-grade is solely at the Buyer's risk, and that they are solely responsible for compliance with all legal and regulatory requirements in connection with such use.

TI products are neither designed nor intended for use in automotive applications or environments unless the specific TI products are designated by TI as compliant with ISO/TS 16949 requirements. Buyers acknowledge and agree that, if they use any non-designated products in automotive applications, TI will not be responsible for any failure to meet such requirements.

Following are URLs where you can obtain information on other Texas Instruments products and application solutions:

### Products

|                        |  |
|------------------------|--|
| Audio                  | <a href="http://www.ti.com/audio">www.ti.com/audio</a>                               |
| Amplifiers             | <a href="http://amplifier.ti.com">amplifier.ti.com</a>                               |
| Data Converters        | <a href="http://dataconverter.ti.com">dataconverter.ti.com</a>                       |
| DLP® Products          | <a href="http://www.dlp.com">www.dlp.com</a>   |
| DSP                    | <a href="http://dsp.ti.com">dsp.ti.com</a>   |
| Clocks and Timers      | <a href="http://www.ti.com/clocks">www.ti.com/clocks</a>                             |
| Interface              | <a href="http://interface.ti.com">interface.ti.com</a>                               |
| Logic                  | <a href="http://logic.ti.com">logic.ti.com</a>                                       |
| Power Mgmt             | <a href="http://power.ti.com">power.ti.com</a>                                       |
| Microcontrollers       | <a href="http://microcontroller.ti.com">microcontroller.ti.com</a>                   |
| RFID                   | <a href="http://www.ti-rfid.com">www.ti-rfid.com</a>                                 |
| OMAP Mobile Processors | <a href="http://www.ti.com/omap">www.ti.com/omap</a>                                 |
| Wireless Connectivity  | <a href="http://www.ti.com/wirelessconnectivity">www.ti.com/wirelessconnectivity</a> |

### Applications

|                               |  |
|-------------------------------|--|
| Communications and Telecom    | <a href="http://www.ti.com/communications">www.ti.com/communications</a>                 |
| Computers and Peripherals     | <a href="http://www.ti.com/computers">www.ti.com/computers</a>                           |
| Consumer Electronics          | <a href="http://www.ti.com/consumer-apps">www.ti.com/consumer-apps</a>                   |
| Energy and Lighting           | <a href="http://www.ti.com/energy">www.ti.com/energy</a>                                 |
| Industrial                    | <a href="http://www.ti.com/industrial">www.ti.com/industrial</a>                         |
| Medical                       | <a href="http://www.ti.com/medical">www.ti.com/medical</a>                               |
| Security                      | <a href="http://www.ti.com/security">www.ti.com/security</a>                             |
| Space, Avionics and Defense   | <a href="http://www.ti.com/space-avionics-defense">www.ti.com/space-avionics-defense</a> |
| Transportation and Automotive | <a href="http://www.ti.com/automotive">www.ti.com/automotive</a>                         |
| Video and Imaging             | <a href="http://www.ti.com/video">www.ti.com/video</a>                                   |

TI E2E Community Home Page

[e2e.ti.com](http://e2e.ti.com)

Mailing Address: Texas Instruments, Post Office Box 655303, Dallas, Texas 75265  
Copyright © 2011, Texas Instruments Incorporated