

Low-Power, 8-bit, 3-Channel Analog to Digital Converters

Features

- **Supply Input Voltages Range: 2.8V to 5.5V**
- **100uA Low Supply Current**
- **3-Ch Analog Voltage Input: AIN1, AIN2, AIN3**
- **High Accuracy Nonlinearity: $\pm 1.5\text{LSB}$**
- **High Accuracy A/D Resolution: 10mV**
- **High Accuracy A/D Full Scale Range: 1~3.56V**
- **Built-in Alert Flag Functions**
- **Built-in I²C Address Programming Functions**
- **I²C interface with 8-bit AD converter**
- **SOT23-8 with Lead Free & RoHS compliant**

General Description

The APL6002 is a precision analog-to-digital converters (ADCs) with 8 bits of resolution, which designed with precision, low power and ease of implementation in mind. Data are transferred via an I²C-compatible serial interface. Three voltage sensing inputs are available for monitoring the temperature of the system. It measures voltage form the monitor place to GND by NTC resistor divider voltages. The sensed voltages are digitized and interfaced with microprocessor by I²C bus for advanced power management procedures.

The APL6002 operates from a single power supply ranging from 2.8V to 5.5V.

This APL6002 is available in SOT23-8 package.

Pin Configurations

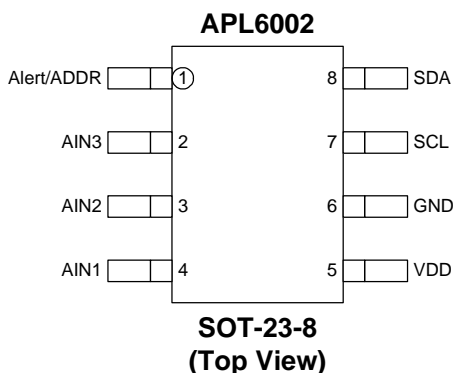

Applications

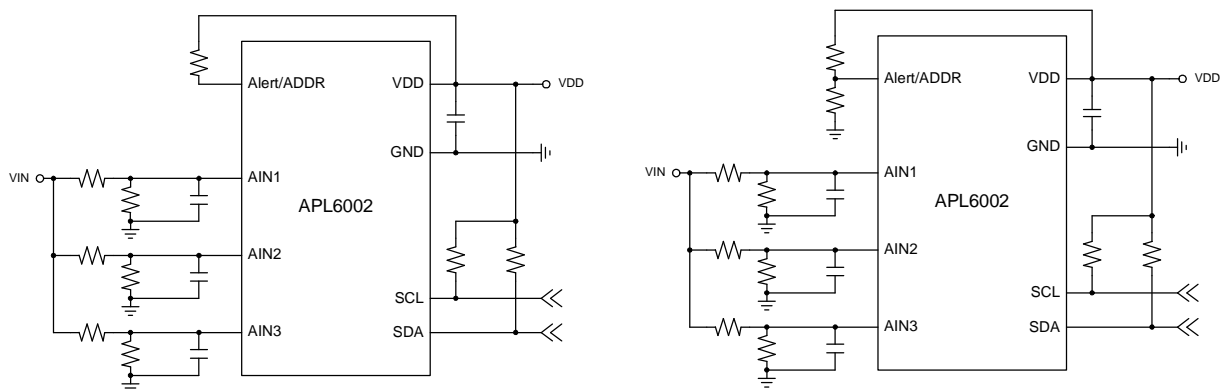

- **Phone & NB Application**
- **Temperature Measurement**
- **Portable Instrumentation**
- **Consumer Goods**

Simplified Application Circuit

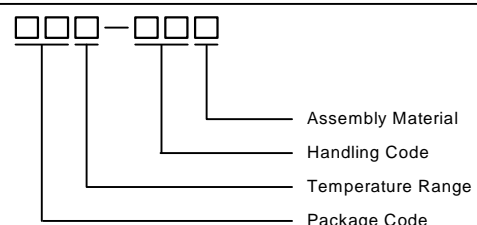

ANPEC reserves the right to make changes to improve reliability or manufacturability without notice, and advise customers to obtain the latest version of relevant information to verify before placing orders.

Ordering and Marking Information

<p>APL6002 □□□-□□□</p>  <p> Assembly Material Handling Code Temperature Range Package Code </p>	<p>Package Code A8 : SOT-23-8</p> <p>Operating Ambient Temperature Range I : -40 to 85°C</p> <p>Handling Code TR : Tape & Reel</p> <p>Assembly Material G : Halogen and Lead Free Device</p>
<p>APL6002 A8  602X</p> <p style="text-align: right;">X : Date Code</p>	

Note : ANPEC lead-free products contain molding compounds/die attach materials and 100% matte tin plate termination finish; which are fully compliant with RoHS. ANPEC lead-free products meet or exceed the lead-free requirements of IPC/JEDEC J-STD-020D for MSL classification at lead-free peak reflow temperature. ANPEC defines "Green" to mean lead-free (RoHS compliant) and halogen free (Br or Cl does not exceed 900ppm by weight in homogeneous material and total of Br and Cl does not exceed 1500ppm by weight).

Absolute Maximum Ratings (Note 1)

Symbol	Parameter	Rating	Unit
VDD	VDD Supply Voltage, VDD to GND	-0.3 ~ 6.0	V
V _{IO}	Input & Output or I/O (Alert/ADDR, SCL, SDA, AIN1, AIN2, AIN3) voltages	-0.3 ~ VDD	V
PD	Power Dissipation	Internally Limited	W
T _J	Junction Temperature	150	°C
T _{STG}	Storage Temperature	-65 ~ 150	°C
T _{SDR}	Maximum Lead Soldering Temperature(10 Seconds)	260	°C
V _{ESD}	Minimum ESD Rating	(Human Body Mode) ±2 (MM Mode) 0.2	kV

Note1: Stresses beyond those listed under "absolute maximum ratings" may cause permanent damage to the device. These are stress ratings only and functional operation of the device at these or any other conditions beyond those indicated under "recommended operating conditions" is not implied. Exposure to absolute maximum rating conditions for extended periods may affect device reliability.

Thermal Characteristics

Symbol	Parameter	Typical Value	Unit
θ _{JA}	Junction-to-Ambient Resistance in free air (Note 2)	230	°C/W

Note 2 : θ_{JA} is measured with the component mounted on a high effective thermal conductivity test board in free air.

Recommended Operating Conditions (Note 3)

Symbol	Parameter	Range	Unit
VDD	VDD Supply Voltage, VDD to GND	2.8 ~ 5.5	V
V _{IO}	Input & Output pins (Alert/ADDR, SCL, SDA) voltage	0 ~ VDD	V
V _{AIN}	Input pins (AIN1, AIN2, AIN3) voltage	1 ~ 3.56	V
T _A	Ambient Temperature	-40 ~ 85	°C
T _J	Junction Temperature	-40 ~ 125	°C

Electrical Characteristics

Unless otherwise specified, these specifications apply over $V_{DD}=5V$, and $T_J = -40$ to $85^{\circ}C$. Typical values are at $T_J=25^{\circ}C$.

Symbol	Parameter	Test condition	Specification			Unit
			Min.	Typ.	Max.	
SUPPLY CURRENT						
I_{VDD}	VDD Input Current		-	80	100	μA
POWER-ON RESET (POR)						
V_{POR}	VDD POR Threshold Voltage	VDD Rising	-	2.35	2.6	V
V_{POR_Hys}	VDD POR Hysteresis Voltage	VDD Falling	-	0.1	-	V
Voltage Monitor						
A/D	A/D Resolution		-	10	-	mV/LSB
	A/D Full Scale Range		1	-	3.56	V
	Differential nonlinearity		-	-	1.5	LSB
	Differential nonlinearity	VDD=3.6V	-	-	2.5	LSB
	Integral nonlinearity		-	-	1.5	LSB
	Integral nonlinearity	VDD=3.6V	-	-	2.5	LSB
	Input Bias Current		-	-	10	nA
	AIN1, AIN2, AIN3 Monitor Time		-	0.6	0.72	ms
Address Setting and Alert Output						
ADDR	Address Latch Time		-	-	10	ms
	Address 1 Voltage Range	Address = 0x7E (Hex)	92	95	100	%VDD
	Address 2 Voltage Range	Address = 0x7C (Hex)	82	85	88	%VDD
	Address 3 Voltage Range	Address = 0x7A (Hex)	72	75	78	%VDD
	Address 4 Voltage Range	Address = 0x78 (Hex)	63	65	68	%VDD
	Address 5 Voltage Range	Address = 0x76 (Hex)	52	55	58	%VDD
	Address 6 Voltage Range	Address = 0x74 (Hex)	42	45	48	%VDD
	Address 7 Voltage Range	Address = 0x72 (Hex)	32	35	38	%VDD
	Address 8 Voltage Range	Address = 0x70 (Hex)	0	25	28	%VDD
Alert	Alert Output Low Voltage	When Alert/ADDR pin pull low, $I_{ALT}=10mA$	-	-	0.2	V
		When Alert/ADDR pin pull low, $I_{ALT}=50mA$	-	-	0.8	V
	Alert Pull Low Pulse Time	When Alert/ADDR pin Alert	-	50	-	μs
	Alert Pull Low cycle Time	When Alert/ADDR pin Alert	-	2	-	s
	Alert/ADDR Leakage Current	$V_{Alert/ADDR}=5V$	-	-	100	nA
I²C Interface						
F_{I2C}	I ² C Clock Rate Range		-	-	400	kHz
	I ² C Input High Voltage		1.4	-	-	V
	I ² C Input Low Voltage		-	-	0.4	V
	I ² C Leakage Current	$V_{SCL}=V_{SDA}=5V$	-	-	100	nA

Electrical Characteristics (Cont.)

Timing characteristics for I²C Interface signals over recommended operating conditions (unless otherwise noted)

Symbol	Parameter	Fast Speed		Unit
		Min.	Max.	
f_{SCL}	Frequency, SCL	-	400	kHz
$t_{W(H)}$	Pulse Duration, SCL High	600	-	ns
$t_{W(L)}$	Pulse Duration, SCL Low	1300	-	ns
t_r	Rise Time, SCL and SDA	$20+0.1 C_L(pF)$	300	ns
t_f	Fall Time, SCL and SDA	$20+0.1 C_L(pF)$	300	ns
t_{setup1}	Setup Time, SCL to SDA	100	-	ns
t_{hold1}	Hold Time, SCL to SDA	100	-	ns
$t_{(buf)}$	Bus Free Time Between Stop and Start Condition	1300	-	ns
t_{setup2}	Setup Time, SCL to Start Condition	600	-	ns
t_{hold2}	Hold Time, Start condition to SCL	600	-	ns
t_{setup3}	Setup Time, SCL to Stop Condition	600	-	ns
C_L	Load Capacitance for Each Bus Line	-	400	pF

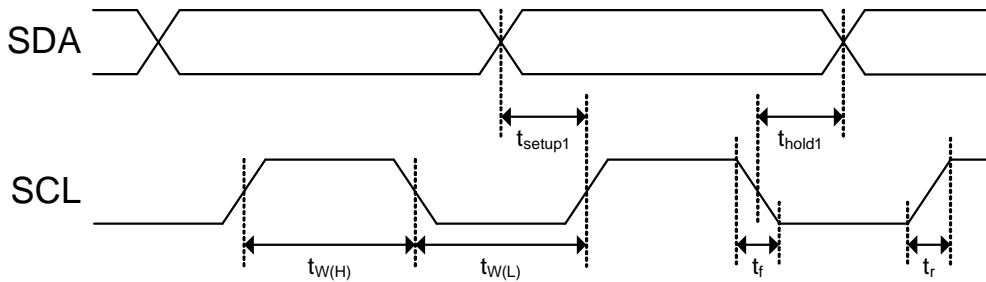

SDA and SCL Timing

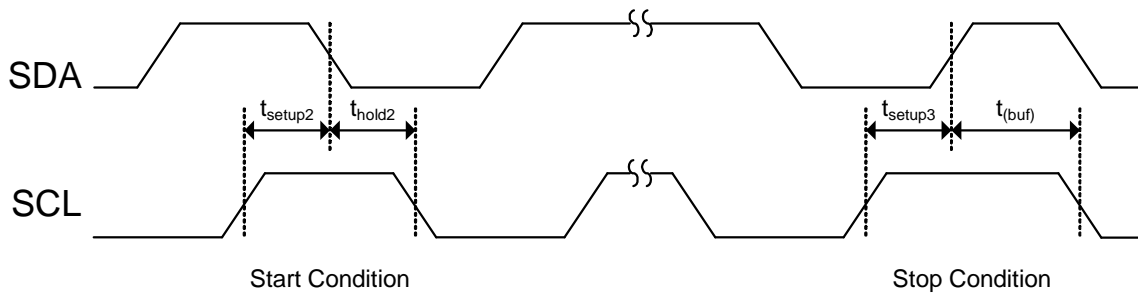

Start and Stop Condition Timing

Typical Operating Characteristics

AIN1 vs. Reg0x03

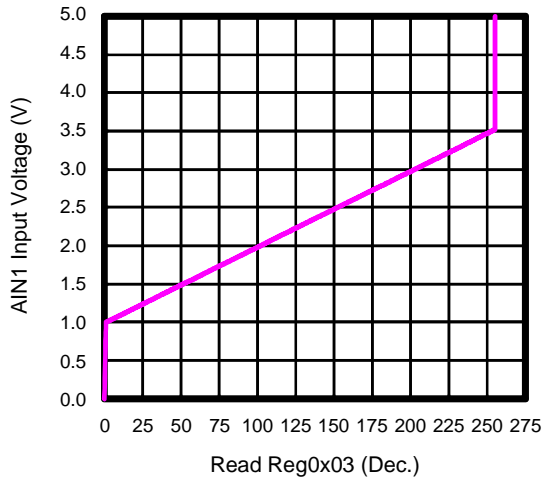

AIN2 vs. Reg0x04

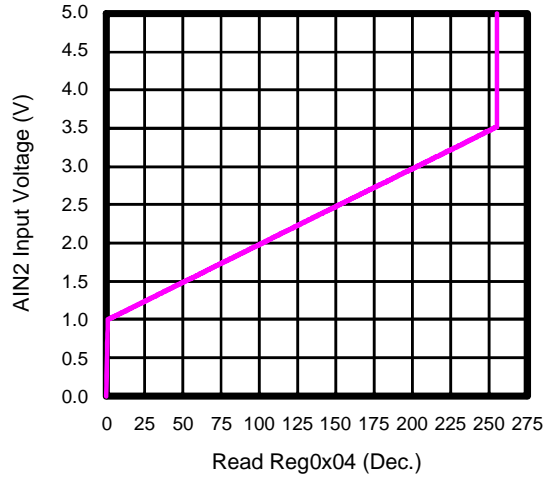

AIN3 vs. Reg0x05

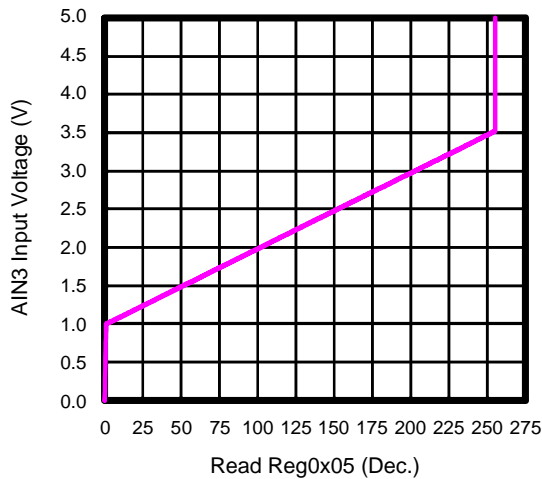

Quiescent Current vs. VDD

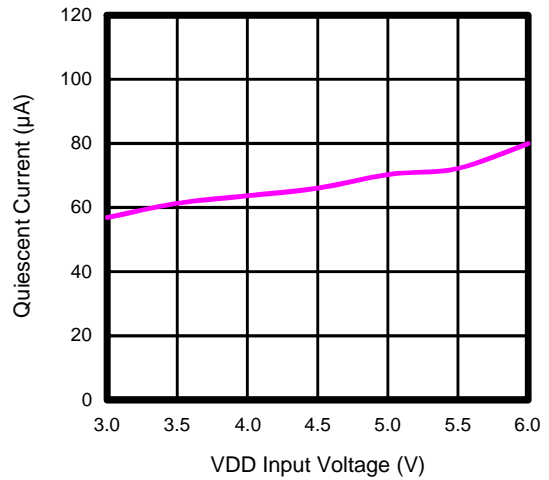

Quiescent Current vs. Temperature

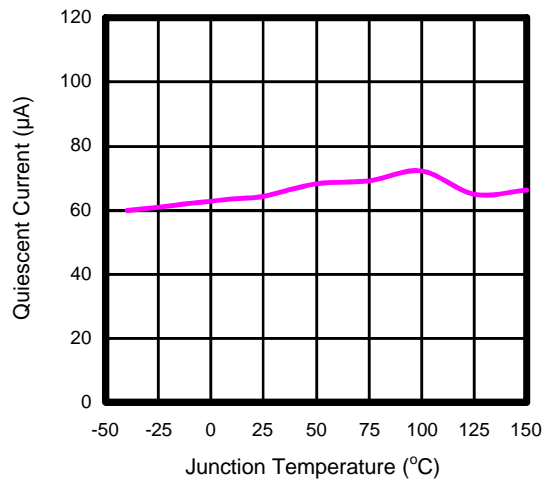

Alert Low Pulse Time vs. VDD

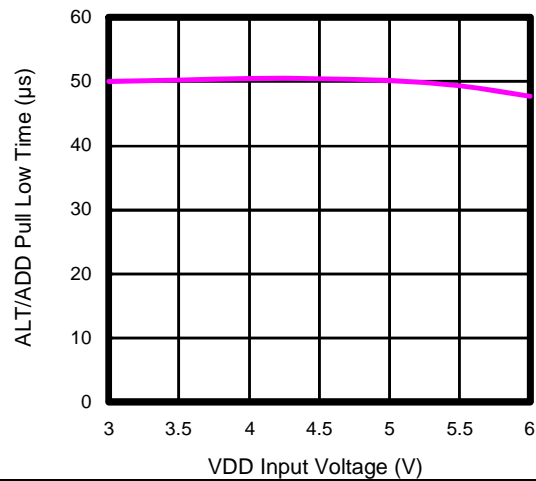

Typical Operating Characteristics

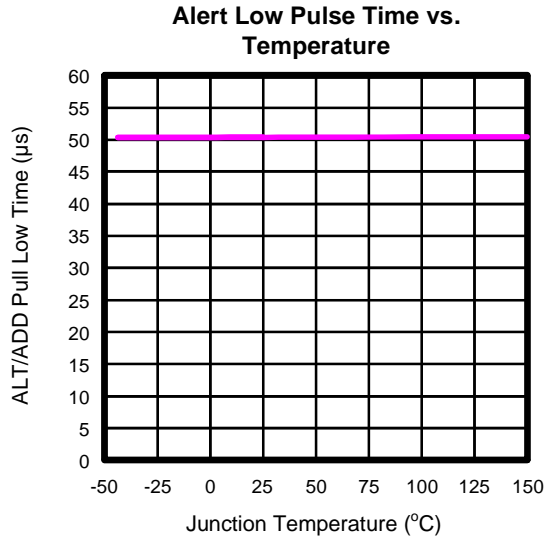

Pin Description

PIN		FUNCTION
NO.	NAME	
1	Alert/ADDR	Address Selection and Thermal Alert. Connect a voltage divider to select the APL6002 I ² C address. When anyone of V _{AINx} is lower than setting voltage, it will pull low and send alert signal to the system. Connect this pin without any capacitor. Do not leave Alert/ADDR pin floating.
2	AIN3	Analog Voltage Input 3.
3	AIN2	Analog Voltage Input 2.
4	AIN1	Analog Voltage Input 1.
5	VDD	Device power supply pin. Connect this pin with 0.1uF capacitor.
6	GND	Signal and Power Ground. All the voltage levels are measured by reference to this pin.
7	SCL	I ² C interface Clock I/O pin. Connect this pin to I ² C bus clock signal.
8	SDA	I ² C interface Data I/O pin. Connect this pin to I ² C bus data signal.

Block Diagram

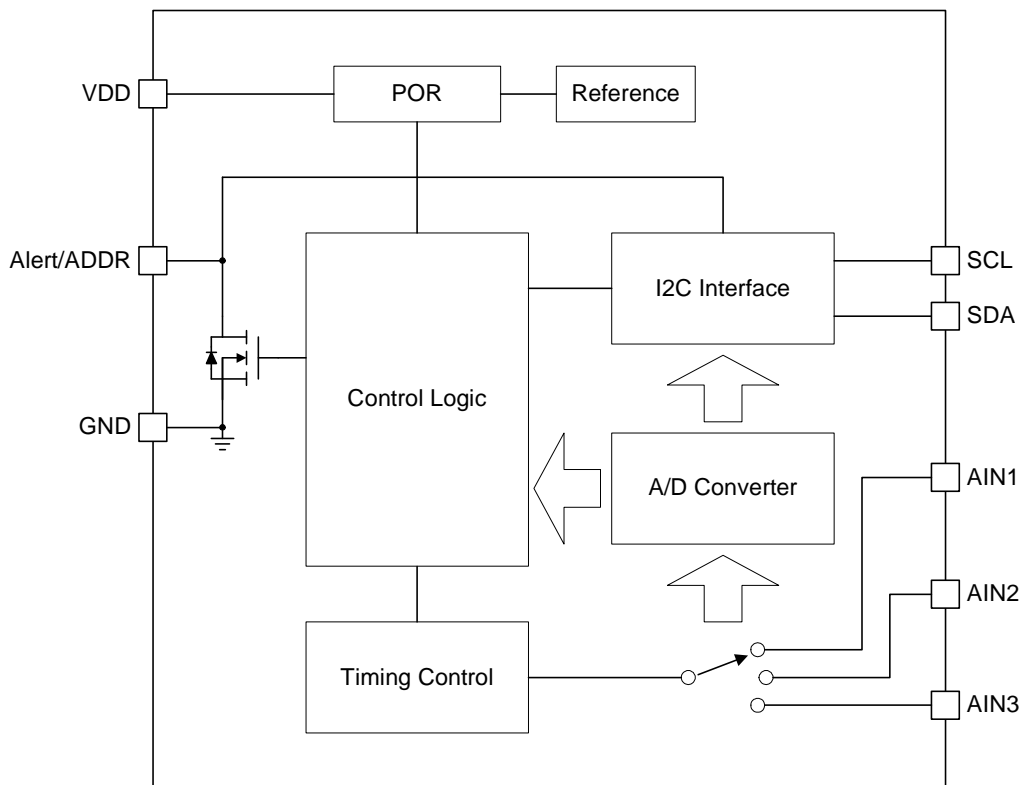

Typical Application Circuit

The I²C Address Programming and Alert Flag functions are used.

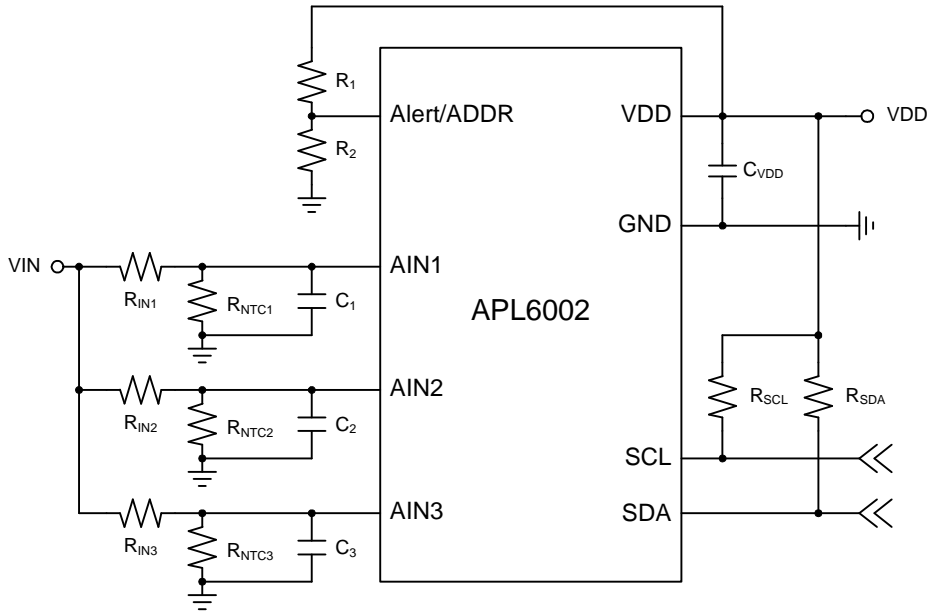

The I²C Address is used as default and Alert Flag function is unused.

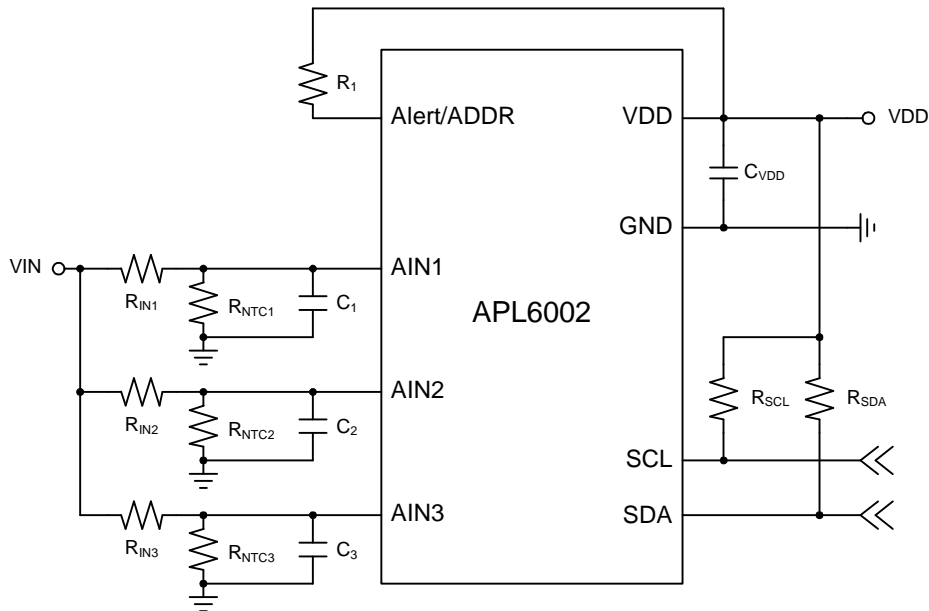

- $V_{AINx} = 1\sim 3.56V$ is recommended.
- R_{INx} and R_{NTCx} = 10k Ω ~10M Ω is recommended.
- C_{VDD} , C_1 , C_2 and $C_3 \geq 0.1\mu F$ is recommended.
- R_{SCL} and R_{SDA} = 1k Ω ~10k Ω is recommended.

Function Description

Input Voltage and Power-On-Reset

The APL6002 can work normally and start monitoring the AINx voltage, when the supply voltage VDD is greater than the POR. The POR threshold is 2.5V typically when the VDD rising.

I²C Interface Data Validity

The SCL voltage level can only be changed to Low to High, when the SDA is stable unless the START and STOP status. The SDA can only be changed the voltage level when the SCL voltage is Low.

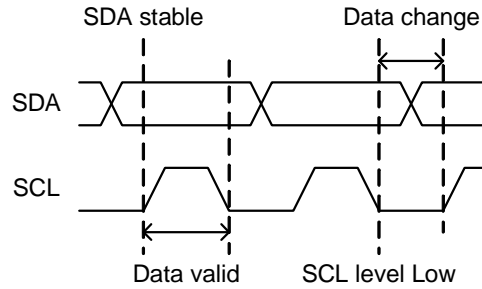

I²C Start and Stop Conditions

The START (S) condition is the SDA transient from High to Low, when SCL is High. The STOP (P) condition is the SDA transient from Low to High, when SCL is High. The STOP condition must send before each START condition.

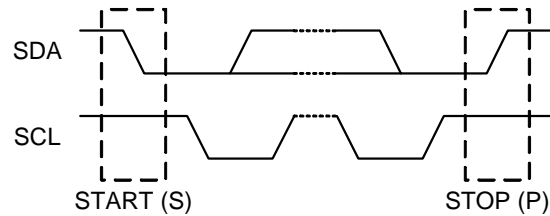

I²C Acknowledge

Each Address and Data are transmitted by using 8 clock pulses with 1 clock pulse Acknowledge (A). The Acknowledge is used for two purposes: one is the device that recognizes its own address. Another one is all of the master and slave to acknowledge receipt the register address or data. The SDA will pull Low to acknowledge.

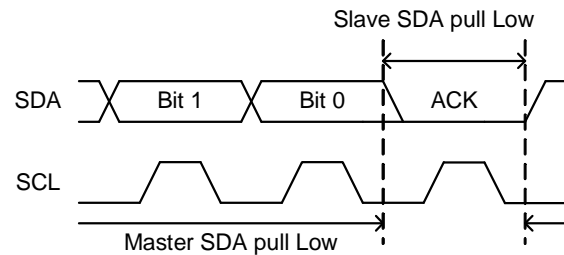

Read and Write Protocol

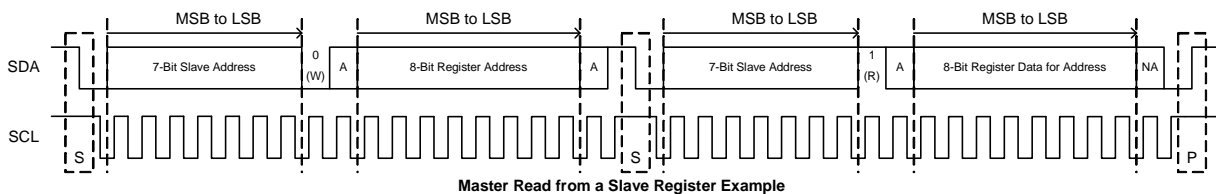
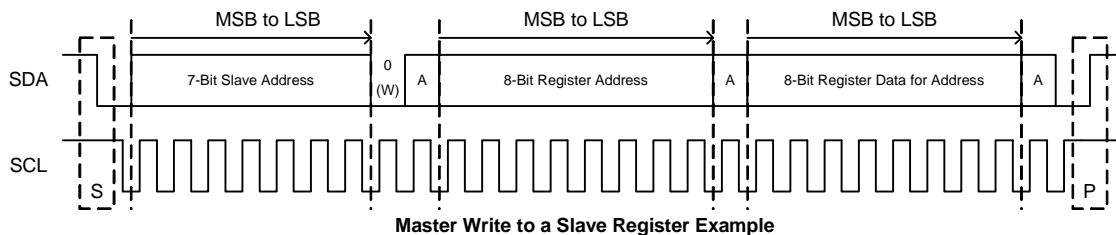

(S=START, P=STOP, A=ACK from Slave, NA=Non-ACK)

Function Description (Cont.)

I²C Address Programming

The APL6002 I2C address is programmable, which can be selected from 0x70h to 0x7Eh by the 7-bit slave address with one R/W bit. The slave device compares the 7-bit slave address with its address and matches. The programmable address is selected by a voltage divider R1 and R2. The Alert/ADDR pin voltage is compared with 8 addresses available internal reference voltage for address programming.

Note: If the address programming function is not used, the Alert/ADDR pin must be connected to VDD via a resistor and the I2C address is used as default value 0x7Eh.

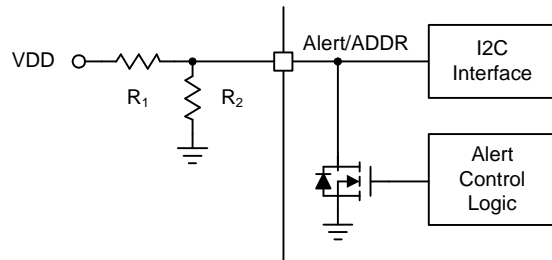

Address	0x70	0x72	0x74	0x76	0x78	0x7A	0x7C	0x7E
R1 (kOhm)	6	5.1	4.3	3.9	3.6	2	1.5	10
R2 (kOhm)	2	2.7	3.6	4.7	6.8	6.2	8.2	Open
ALT/ADDR (% of VDD)	25	35	45	55	65	75	85	100

Voltage Monitoring and I²C Programming Interface

The AINx voltages are digitized directly by high precision A/D converter and interfaced to the I²C bus. The AINx voltages are sensed alternately and take 0.6ms every channel.

When the VDD supply voltage range from 2.8 to 5.5V, the A/D converter have 10mV of resolution, and 1 to 3.56V of full scale range. The A/D converter sensing results are stored in the internal register that shows as follow:

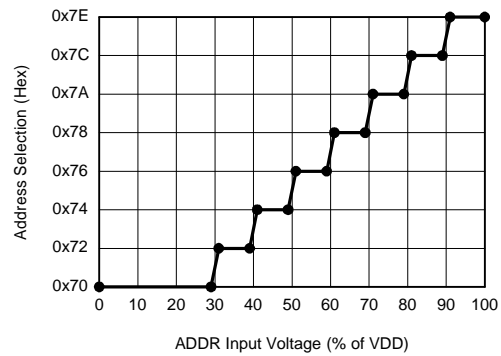

AIN1 A/D data store (TD1): Reg0x03[7] (MSB) ~ Reg0x03 [0] (LSB)

AIN2 A/D data store (TD2): Reg0x04[7] (MSB) ~ Reg0x04 [0] (LSB)

AIN3 A/D data store (TD3): Reg0x05[7] (MSB) ~ Reg0x05 [0] (LSB)

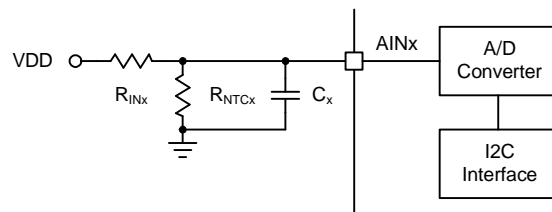

If the internal register code is read as Code_x in integer decimal format, the AINx voltage transition to the internal register Reg0x03, Reg0x04 and Reg0x05 calculation as follows:

$$\text{Code}_x = \frac{V_{\text{AINx}} - 1V}{10\text{mV}} \quad \text{or} \quad V_{\text{AINx}} = (10\text{mV} \times \text{Code}_x) + 1V$$

The voltage divider at VIN-R_{INx}-R_{NTCx}-GND sets the voltage AINx is calculated as:

$$V_{\text{AINx}} = \text{VIN} \times \frac{R_{\text{NTCx}}}{R_{\text{INx}} + R_{\text{NTCx}}}$$

According to the above equation:

$$\text{Code}_x = \frac{\left(\text{VIN} \times \frac{R_{\text{NTCx}}}{R_{\text{INx}} + R_{\text{NTCx}}} \right) - 1V}{10\text{mV}}$$

Note: If the AINx pin is not used, that must be pulled to the high level. And the C_x is recommended to bypass the AINx pin.

Function Description (Cont.)

Alert Flag

The Alert Flag is used to indicate the system state. When the setting condition is established at the AINx voltage, the APL6002 will make the internal MOS in the Alert pin turns on and pull low 50us every 2s cycle time.

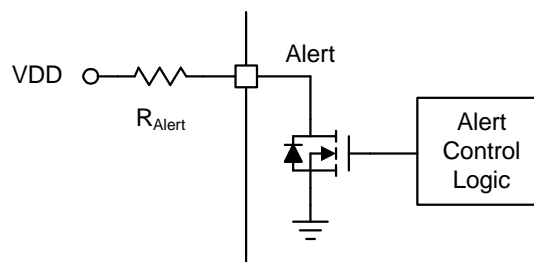

Alert Threshold Level Setting

The Alert levels are set in the internal register by I²C interface shows as follows:

AIN1 Alert level set-up (TL1): Reg0x00[7] (MSB) ~ Reg0x00[0] (LSB)

AIN2 Alert level set-up (TL2): Reg0x01[7] (MSB) ~ Reg0x01[0] (LSB)

AIN3 Alert level set-up (TL3): Reg0x02[7] (MSB) ~ Reg0x02[0] (LSB)

If one of conditions is established include $TL1 \geq TD1$, $TL2 \geq TD2$ or $TL3 \geq TD3$, the Alert function will be enabled, and the Alert Indication of internal resistor Reg0x06[6:4] will be set to 1 that shows as below:

If the Reg0x00 (TL1) \geq Reg0x03 (TD1), than the bit Reg0x06[4] = 1, else the bit Reg0x06[4] = 0

If the Reg0x01 (TL2) \geq Reg0x04 (TD2), than the bit Reg0x06[5] = 1, else the bit Reg0x06[5] = 0

If the Reg0x02 (TL3) \geq Reg0x05 (TD3), than the bit Reg0x06[6] = 1, else the bit Reg0x06[6] = 0

Chip ID: Reg0xB2[7:0] = 0x1A

I²C Registers Summary

Register Address	Register Name	Bits								Read/Write	Default Value
		D7	D6	D5	D4	D3	D2	D1	D0		
0x00	TL1	TL1[7:0]								R/W	00h
0x01	TL2	TL2[7:0]								R/W	00h
0x02	TL3	TL3[7:0]								R/W	00h
0x03	TD1	TD1[7:0]								R	00h
0x04	TD2	TD2[7:0]								R	00h
0x05	TD3	TD3[7:0]								R	00h
0x06	ALT	Reversed	AM3	AM2	AM1	Reversed			R	00h	
0xB2	Chip ID	Chip ID = 0x1A								R	1Ah

Manufature Information

APL6002 manufacturing information. Including wafer fab and assembly location.

ANPEC Device	Manufature	Assembly
APL6002	TSMC	GTK / CJE

ANPEC Electronic Corp.
Account manager
Kevin Chang

A handwritten signature in black ink, appearing to be "Kevin Chang". The signature is written in a cursive style with a long horizontal stroke at the end.

Package Information

SOT-23-8

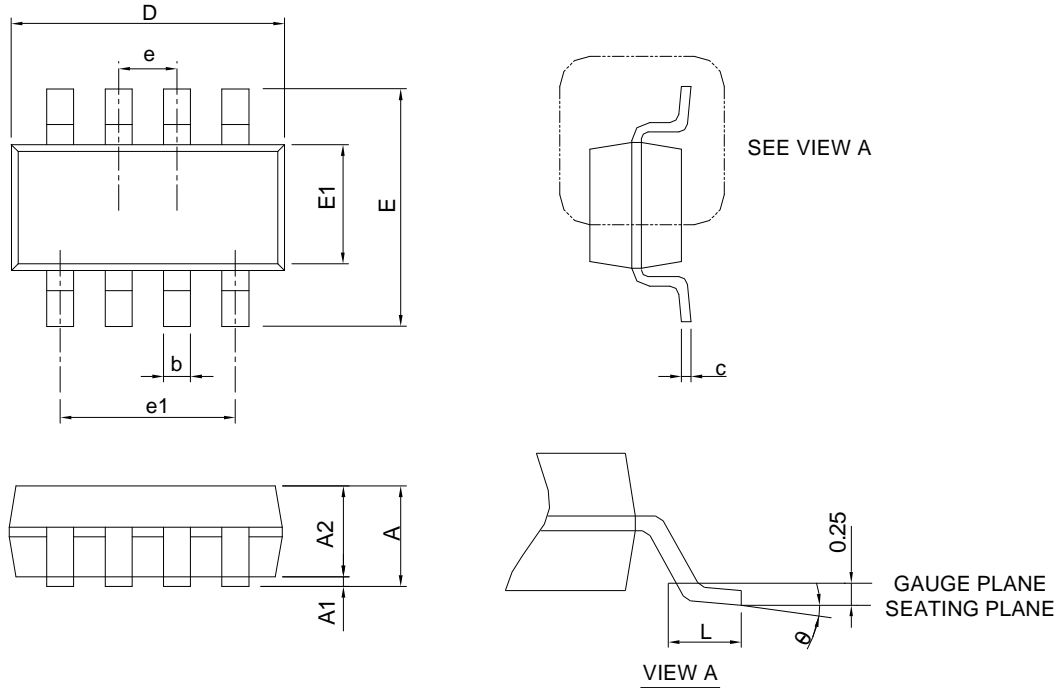

DIMENSIONS	SOT-23-8			
	MILLIMETERS		INCHES	
	MIN.	MAX.	MIN.	MAX.
A		1.45		0.057
A1	0.00	0.15	0.000	0.006
A2	0.90	1.30	0.035	0.051
b	0.22	0.38	0.009	0.015
c	0.08	0.22	0.003	0.009
D	2.70	3.10	0.106	0.122
E	2.60	3.00	0.102	0.118
E1	1.40	1.80	0.055	0.071
e	0.65 BSC		0.026 BSC	
e1	1.95 BSC		0.077 BSC	
L	0.30	0.60	0.012	0.024
θ	0°	8°	0°	8°

Note : 1. Follow JEDEC MO-178 BA.
 2. Dimension D and E1 do not include mold flash, protrusions or gate burrs. Mold flash, protrusion or gate burrs shall not exceed 10 mil per side.

Carrier Tape & Reel Dimensions

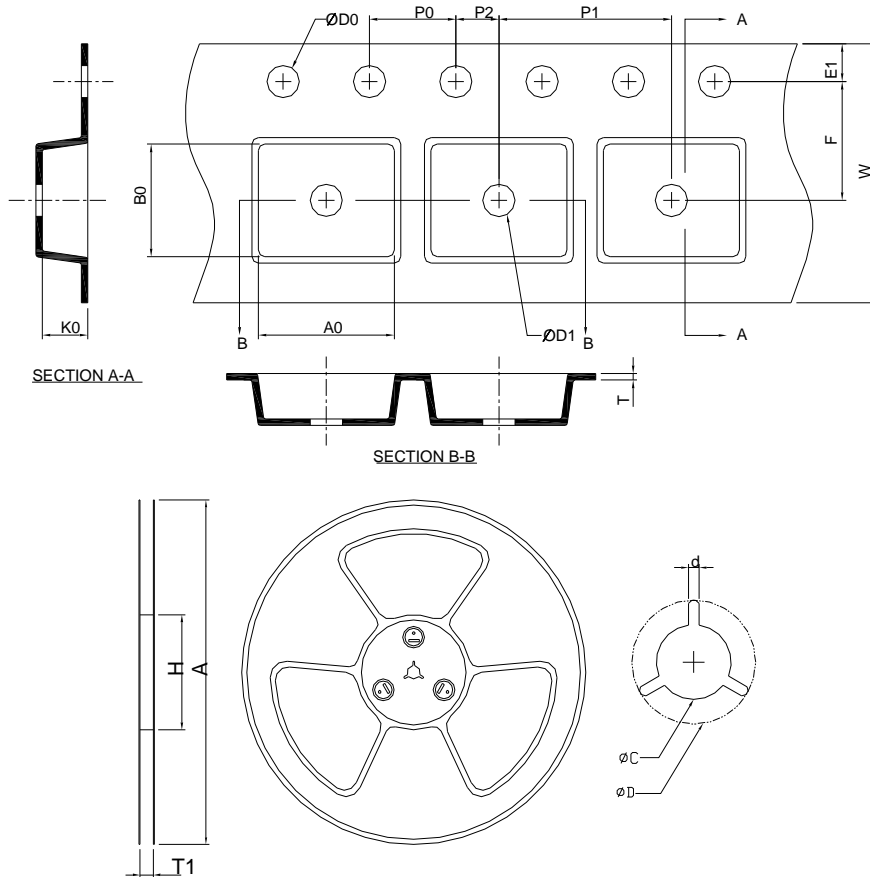

Application	A	H	T1	C	d	D	W	E1	F
SOT-23-8	178.0±2.00	50 MIN.	8.4+2.00 -0.00	13.0+0.50 -0.20	1.5 MIN.	20.2 MIN.	8.0±0.30	1.75±0.10	3.5±0.05
	P0	P1	P2	D0	D1	T	A0	B0	K0
	4.0±0.10	4.0±0.10	2.0±0.05	1.5+0.10 -0.00	1.0 MIN.	0.6+0.00 -0.40	3.20±0.20	3.10±0.20	1.50±0.20

(mm)

Devices Per Unit

Package Type	Unit	Quantity
SOT-23-8	Tape & Reel	3000

Taping Direction Information

SOT-23-8

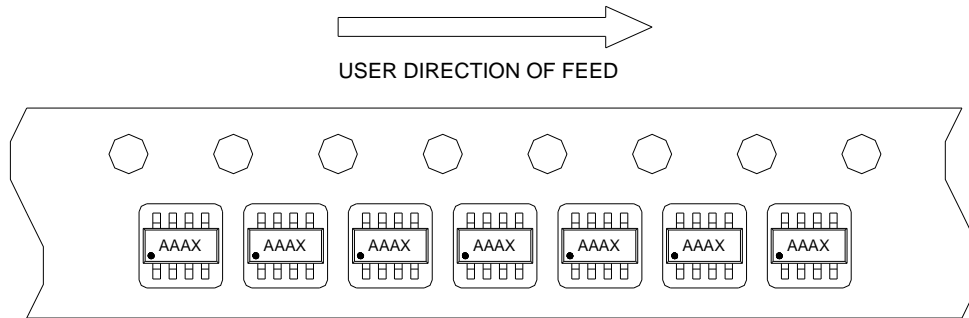

Classification Profile

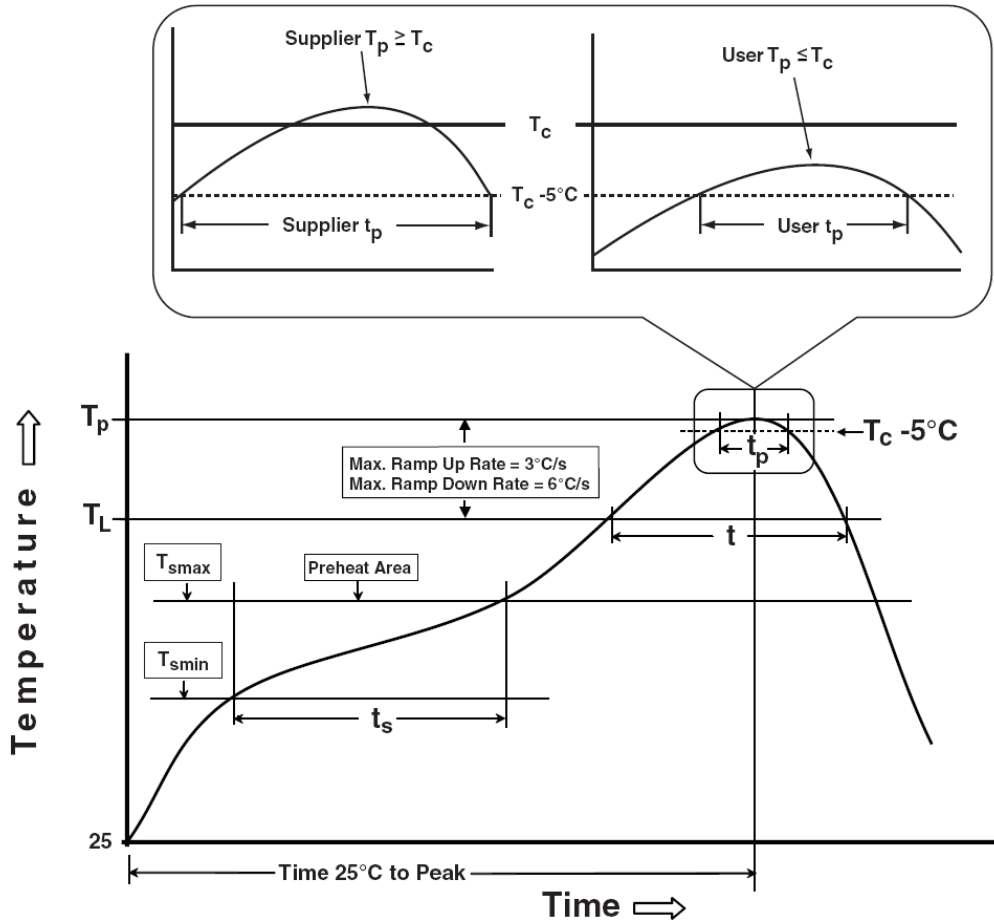

Classification Reflow Profiles

Profile Feature	Sn-Pb Eutectic Assembly	Pb-Free Assembly
Preheat & Soak		
Temperature min (T_{smin})	100 °C	150 °C
Temperature max (T_{smax})	150 °C	200 °C
Time (T_{smin} to T_{smax}) (t_s)	60-120 seconds	60-120 seconds
Average ramp-up rate (T_{smax} to T_p)	3 °C/second max.	3°C/second max.
Liquidous temperature (T_L)	183 °C	217 °C
Time at liquidous (t_l)	60-150 seconds	60-150 seconds
Peak package body Temperature (T_p)*	See Classification Temp in table 1	See Classification Temp in table 2
Time (t_p)** within 5°C of the specified classification temperature (T_c)	20** seconds	30** seconds
Average ramp-down rate (T_p to T_{smax})	6 °C/second max.	6 °C/second max.
Time 25°C to peak temperature	6 minutes max.	8 minutes max.

* Tolerance for peak profile Temperature (T_p) is defined as a supplier minimum and a user maximum.
 ** Tolerance for time at peak profile temperature (t_p) is defined as a supplier minimum and a user maximum.

Classification Reflow Profiles (Cont.)

Table 1. SnPb Eutectic Process – Classification Temperatures (Tc)

Package Thickness	Volume mm ³ <350	Volume mm ³ ≥350
<2.5 mm	235 °C	220 °C
≥2.5 mm	220 °C	220 °C

Table 2. Pb-free Process – Classification Temperatures (Tc)

Package Thickness	Volume mm ³ <350	Volume mm ³ 350-2000	Volume mm ³ >2000
<1.6 mm	260 °C	260 °C	260 °C
1.6 mm – 2.5 mm	260 °C	250 °C	245 °C
≥2.5 mm	250 °C	245 °C	245 °C

Reliability Test Program

Test item	Method	Description
SOLDERABILITY	JESD-22, B102	5 Sec, 245°C
HOLT	JESD-22, A108	1000 Hrs, Bias @ Tj=125°C
PCT	JESD-22, A102	168 Hrs, 100%RH, 2atm, 121°C
TCT	JESD-22, A104	500 Cycles, -65°C~150°C
HBM	MIL-STD-883-3015.7	VHBM ≥ 2KV
MM	JESD-22, A115	VMM ≥ 200V
Latch-Up	JESD 78	10ms, 1 _{tr} ≥ 100mA

Customer Service

Anpec Electronics Corp.

Head Office :

No.6, Dusing 1st Road, SBIP,
Hsin-Chu, Taiwan, R.O.C.
Tel : 886-3-5642000
Fax : 886-3-5642050

Taipei Branch :

2F, No. 11, Lane 218, Sec 2 Jhongsing Rd.,
Sindian City, Taipei County 23146, Taiwan
Tel : 886-2-2910-3838
Fax : 886-2-2917-3838