



# TDA7540B

## AM/FM Car Radio Tuner IC with Stereo Decoder and Intelligent Selectivity System (ISS)

### Features

#### FM-Part

- RF AGC generation by RF and IF detection
- I/Q mixer for 1st FM IF 10.7MHz with image rejection
- Mixer for 2nd IF 450kHz
- Internal 450kHz bandpass filter with bandwidth control by ISS
- Fully integrated FM-demodulator with spike cancellation

#### AM-Part

- Wide and narrow AGC generation
- Mixer for 1st IF 10.7MHz, AM upconversion
- Mixer for 2nd IF 450kHz, AM downconversion
- Integrated AM-demodulator
- AM IF- and audio noise blanking

#### Stereodecoder

- PLL with adjustment free, fully integrated VCO
- Automatic pilot dependent MONO/STEREO switching
- Programmable ROLL-OFF compensation
- High cut and stereo blend-characteristics programmable
- Dedicated RDS-mute
- Internal noise blanker with several threshold controls

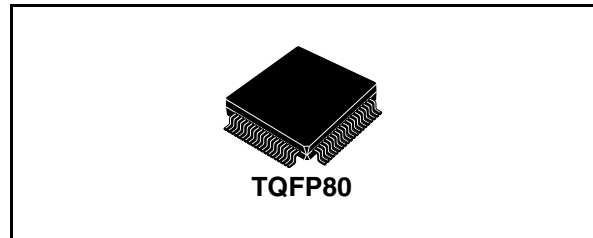

#### Additional Features

- VCO for world tuning range
- High performance fast PLL for RDS-System
- IF counter for FM and AM with search stop signal
- Quality detector for level, deviation, adjacent channel and multipath
- ISS (Intelligent Selectivity System) for cancellation of adjacent channel and noise influences
- Adjacent channel mute
- Fully electronic alignment
- All functions I<sup>2</sup>C-Bus controlled

#### Description

The TDA7540B is a high performance tuner circuit for AM/FM car radio. It contains mixer, IF amplifier, demodulator for AM and FM, stereodecoder, quality detection, ISS filter and PLL synthesizer with IF counter on a single chip. Use of BICMOS technology allows the implementation of several tuning functions and a minimum of external components.

### Order codes

Part number	Temp range, °C	Package	Packing
TDA7540B	-40 to 85	TQFP80	Tray
TDA7540BTR	-40 to 85	TQFP80	Tape & reel

# Contents

<b>1</b>	<b>Block diagram</b>	<b>4</b>
<b>2</b>	<b>Pins description and connection diagrams</b>	<b>5</b>
2.1	TQFP80 pins connection diagram	5
2.2	Pin description	5
2.3	Thermal data	7
<b>3</b>	<b>Electrical specifications</b>	<b>8</b>
3.1	Absolute maximum ratings	8
3.2	Electrical characteristics	8
3.2.1	Globals	8
3.2.2	FM section	9
3.2.3	AM section	14
3.2.4	Stereodecoder	16
3.2.5	PLL section	22
<b>4</b>	<b>Functional description</b>	<b>24</b>
4.1	FM section	24
4.1.1	Mixer1, AGC and 1.IF	24
4.1.2	Mixer2, limiter and demodulator	24
4.1.3	Quality detection and ISS	24
4.1.4	Soft mute control	25
4.2	AM section	26
4.3	Stereodecoder	26
4.3.1	Decoder	26
4.3.2	Functional description of the noise blanker	29
4.3.3	Functional description of the multipath-detector	30
4.3.4	Quality detector	31
4.3.5	AFS control and stereo decoder mute	31
4.4	PLL and if counter section	32
4.4.1	PLL frequency synthesizer block	32
4.4.2	IF counter block	33
4.5	I <sup>2</sup> C-Bus interface	34

---

4.5.1	Data transition .....	34
4.5.2	Start condition .....	34
4.5.3	Stop condition .....	35
4.5.4	Acknowledge .....	35
4.5.5	Data transfer .....	35
4.5.6	Device addressing .....	35
4.5.7	Write operation .....	35
4.5.8	Read operation .....	36
<b>5</b>	<b>Software specification .....</b>	<b>37</b>
5.1	Address organization .....	37
5.2	Control register function .....	39
5.2.1	Data Byte Specification .....	43
<b>6</b>	<b>Appendix .....</b>	<b>63</b>
<b>7</b>	<b>Part List (Application and measurment circuit) .....</b>	<b>70</b>
<b>8</b>	<b>Application circuit .....</b>	<b>71</b>
<b>9</b>	<b>Application Notes .....</b>	<b>72</b>
<b>10</b>	<b>Package Information .....</b>	<b>73</b>
<b>11</b>	<b>Revision history .....</b>	<b>74</b>



## 2 Pins description and connection diagrams

### 2.1 TQFP80 pins connection diagram

Figure 2. TQFP80 pins connection (top view)

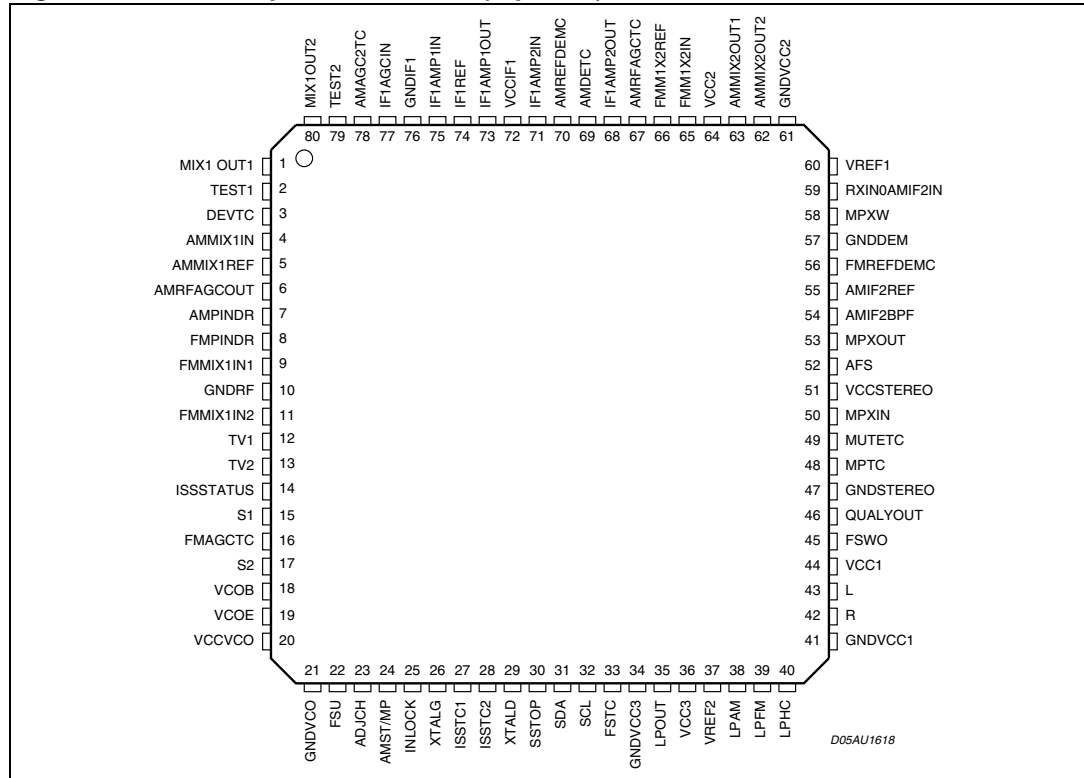

### 2.2 Pin description

Table 1. Pin description

Pin No.	Pin Name	Function
1	MIX1OUT1	Mixer Tank 10.7MHz
2	TEST1	Testing I/O Pin
3	DEVTC	Deviation Detector Time Constant
4	AMMIX1IN	AM Mixer1 Input
5	AMMIX1REF	AM Mixer1 Reference
6	AMRFAGCOUT	Output AM RF AGC
7	AMPINDR	AM PIN Diode Driver Output
8	FMPINDR	FM PIN Diode Driver Output
9	FMMIX1IN1	FM Mixer1 Input1
10	GNDRF	RF Ground
11	FMMIX1IN2	FM Mixer1 Input2

**Table 1. Pin description (continued)**

Pin No.	Pin Name	Function
12	TV1	Tuning Voltage Preselection1
13	TV2	Tuning Voltage Preselection2
14	ISSSTATUS	ISS Filter Status Output
15	S1	Free Programmable Switching Output
16	FMAGCTC	FM AGC Time Constant
17	S2	Free Programmable Switching Output
18	VCOB	VCO Input Base
19	VCOE	VCO Output Emitter
20	VCCVCO	VCO Supply
21	GNDVCO	VCO Ground
22	FSU	Unweighted Fieldstrength Output
23	ADJCH	Ident. Adjacent Channel Output
24	AMST/MP	AM Stereo Output / Ident. Multipath Output
25	INLOCK	PLL Inlock Information Output
26	XTALG	Xtal Oscillator to MOS Gate
27	ISSTC1	Time Constant1 ISS Filter Switch
28	ISSTC2	Time Constant2 ISS Filter Switch
29	XTALD	Xtal Oscillator to MOS Drain
30	SSTOP	Search Stop Output
31	SDA	I <sup>2</sup> C-Bus Data
32	SCL	I <sup>2</sup> C-Bus Clock
33	FSTC	S-meter Filtering Capacitor
34	GNDVCC3	VCC3 Ground
35	LPOUT	Op Amp Output to PLL Loop Filters
36	VCC3	Supply Tuning Voltage
37	VREF2	Voltage Reference for PLL Op Amp
38	LPAM	Op Amp Input to PLL Loop Filters AM
39	LPFM	Op Amp Input to PLL Loop Filters FM
40	LPHC	High Current PLL Loop Filter Input
41	GNDVCC1	Digital Ground
42	R	Stereodecoder Output Right
43	L	Stereodecoder Output Left
44	VCC1	Digital Supply
45	FSWO	Weighted Fieldstrength Output with programmable DC offset
46	Qualyout	Stereodecoder Quality Output
47	GNDSTEREO	Strereodecoder Ground
48	MPTC	Multipath Time Constant
49	MUTETC	Weak Signal Mute Time Constant

**Table 1. Pin description (continued)**

Pin No.	Pin Name	Function
50	MPXIN	Stereodecoder Input
51	VCCSTEREO	Stereodecoder Supply
52	AFS	Alternative Frequency Search Drive
53	MPX/AFAM	MPX Output / AM AF Output
54	AMIF2BPF	AM IF2 Bandpass Filter
55	AMIF2REF	Reference Voltage AM IF2 Amplifier
56	FMREFDEMC	FM Demodulator Reference
57	GNDDEM	Ground FM Demodulator
58	MPXW	MPX Output without ISS Filtering
59	AMIF2IN	Input AM IF2
60	VREF1	Reference 5V
61	GNDVCC2	Analog Ground
62	AMMIX2OUT2	AM Tank 450kHz
63	AMMIX2OUT1	AM Tank 450kHz
64	VCC2	Analog Supply
65	FMMIX2IN	FM IF1 Mixer2 Input
66	FMMIX2REF	FM IF1 Mixer2 Reference
67	AMRFAGCTC	AM RF AGC Time Constant
68	IF1AMP2OUT	IF1 Amplifier2 Output
69	AMDETC	AM Detector Capacitor
70	AMREFDEMC	AM Demodulator Reference
71	IF1AMP2IN	IF1 Amplifier2 Input
72	VCCIF1	IF1 Supply
73	IF1AMP1OUT	IF1 Amplifier1 Output
74	IF1REF	IF1 Amplifier Reference
75	IF1AMP1IN	IF1 Amplifier1 Input
76	GNDIF1	IF1 Ground
77	IF1AGCIN	IF1 AGC Input
78	AMAGC2TC	AM AGC2 Time Constant
79	TEST2	Testing I/O Pin
80	MIX1OUT2	Mixer Tank 10.7MHz

## 2.3 Thermal data

**Table 2. Thermal data**

Symbol	Parameter	Value	Unit
$R_{th(j-amb)}$	Thermal Resistance Junction to ambient	Max. 55	°C/W

### 3 Electrical specifications

#### 3.1 Absolute maximum ratings

**Table 3. Absolute maximum rating**

Symbol	Parameter	Value	Unit
V <sub>S</sub>	Supply voltage	9.5	V
T <sub>amb</sub>	Ambient temperature	-40 to 85	°C
T <sub>stg</sub>	Storage temperature	-55 to 150	°C
V <sub>ESD</sub>	ESD protection (Human Body Model)	±1500	V
V <sub>ESD</sub>	ESD protection (Machine Model)	±150	V
V <sub>ESD</sub>	ESD protection (Change Device Model)	±750	V

#### 3.2 Electrical characteristics

##### 3.2.1 Globals

**Table 4. Electrical characteristics**

(T<sub>amb</sub> = 25°C, V<sub>CC1</sub> = V<sub>CC2</sub> = V<sub>CC3</sub> = V<sub>CCST</sub> = V<sub>CCVCO</sub> = V<sub>CCMIX1</sub> = V<sub>CCMIX2</sub> = V<sub>CCIF1</sub> = 8.5V, f<sub>Xtal</sub> = 10.25MHz, in application circuit, unless otherwise specified).

Item	Symbol	Parameter	Test conditions	Min.	Typ.	Max.	Unit
<b>1</b>	<b>Supply</b>						
1.1	V <sub>CC1</sub>	Digital supply voltage		7.7	8.5	9	V
1.2	V <sub>CC2</sub>	Analog supply voltage		7.7	8.5	9	V
1.3	V <sub>CC3</sub>	Analog tuning voltage		7.7	8.5	9	V
1.4	V <sub>CCVCO</sub>	VCO supply voltage		7.7	8.5	9	V
1.5	V <sub>CCMIX1</sub>	MIX1 supply voltage		7.7	8.5	9	V
1.6	V <sub>CCMIX2</sub>	MIX2 supply voltage		7.7	8.5	9	V
1.7	V <sub>CCIF1</sub>	IF1 supply voltage		7.7	8.5	9	V
1.8	V <sub>CCST</sub>	Stereo supply voltage		7.7	8.5	9	V
1.9	I <sub>CC1</sub>	Supply current	FM ON		8	11	mA
1.10	I <sub>CC1</sub>	Supply current	AM ON		11	14	mA
1.11	I <sub>CC2</sub>	Supply current	FM ON / VCO:1		65	85	mA
1.12	I <sub>CC2</sub>	Supply current	AM ON		75	104	mA
1.13	I <sub>CC3</sub>	Supply current			2	3	mA
1.14	I <sub>CCVCO</sub>	Supply current			9.5	13.5	mA
1.15	I <sub>CCMIX1</sub>	Supply current	FM ON		10	14.5	mA



**Table 4. Electrical characteristics (continued)**

( $T_{amb} = 25^{\circ}\text{C}$ ,  $V_{CC1} = V_{CC2} = V_{CC3} = V_{CCST} = V_{CCVCO} = V_{CCMIX1} = V_{CCMIX2} = V_{CCIF1} = 8.5\text{V}$ ,  $f_{Xtal} = 10.25\text{MHz}$ , in application circuit, unless otherwise specified).

Item	Symbol	Parameter	Test conditions	Min.	Typ.	Max.	Unit
1.16	$I_{CCMIX1}$	Supply current	AM ON		7.5	10	mA
1.17	$I_{CCMIX2}$	Supply current	AM ON		7	8.5	mA
1.18	$I_{CCIF1}$	Supply current			5	6.5	mA
1.19	$I_{CCST}$	Supply current			12	13.6	mA
<b>2</b>	<b>Reference Voltages</b>						
2.1	$V_{REF1}$	Internal reference voltage	$I_{REF1} = 0\text{mA}$	4.8	5	5.2	V
2.2	$V_{REF2}$	Internal reference voltage	$I_{REF2} = 0\text{mA}$	2.3	2.5	2.7	V
<b>3</b>	<b>I<sup>2</sup>C-Bus interface</b>						
3.1	$f_{SCL}$	Clock frequency				400	kHz
3.2	$V_{IL}$	Input low voltage				1	V
3.3	$V_{IH}$	Input high voltage		3		5	V
3.4	$I_{IN}$	Input current		-5		5	$\mu\text{A}$
3.5	$V_O$	Output acknowledge voltage	$I_O = 1.6\text{mA}$			0.4	V

### 3.2.2 FM section

**Table 5. Electrical characteristics**

( $T_{amb} = 25^{\circ}\text{C}$ ,  $V_{CC1} = V_{CC2} = V_{CC3} = V_{CCST} = V_{CCVCO} = V_{CCMIX1} = V_{CCMIX2} = V_{CCIF1} = 8.5\text{V}$ ,  $f_{RF} = 98\text{MHz}$ ,  $\text{dev} = 40\text{kHz}$ ,  $f_{MOD} = 1\text{kHz}$ ,  $f_{Xtal} = 10.25\text{MHz}$ , in application circuit, unless otherwise specified).

Item	Symbol	Parameter	Test Conditions	Min.	Typ.	Max.	Unit
<b>4</b>	<b>Wide Band RF AGC</b>						
4.1	$V_{9-11}$	Lower threshold start	$V_{16} = 2.5\text{V}$	82	85	93	$\text{dB}\mu\text{V}$
4.2	$V_{9-11}$	Upper threshold start	$V_{16} = 2.5\text{V}$	93	96	99	$\text{dB}\mu\text{V}$
<b>5</b>	<b>Narrow Band IF &amp; Keying AGC</b>						
5.1	$V_{77}$	Lower threshold start	KAGC = off, $V_{9-11} = 0\text{mV}_{\text{RMS}}$	83	86	89	$\text{dB}\mu\text{V}$
5.2	$V_{77}$	Upper threshold start	KAGC = off, $V_{9-11} = 0\text{mV}_{\text{RMS}}$	95	98	101	$\text{dB}\mu\text{V}$
5.3	$V_{77}$	Lower threshold start with KAGC	KAGC = max, $V_{9-11} = 0\text{mV}_{\text{RMS}}$ , $\Delta f_{IF} = 300\text{KHz}$	95	98	101	$\text{dB}\mu\text{V}$
5.4	$V_{22}$	Startpoint KAGC	KAGC = max, $V_{9-11} = 0\text{mV}_{\text{RMS}}$ , $\Delta f_{IF} = 300\text{KHz}$ $f_{IF1}$ generates FS level at $V_{22}$		2.2		V
5.5	$\Delta$	Control range KAGC	$\Delta V_{22} = +0.8\text{V}$		16		dB
5.6	$R_{IN}$	Input resistance		10	13	16	$\text{k}\Omega$

**Table 5. Electrical characteristics (continued)**

( $T_{amb} = 25^{\circ}\text{C}$ ,  $V_{CC1} = V_{CC2} = V_{CC3} = V_{CCST} = V_{CCVCO} = V_{CCMIX1} = V_{CCMIX2} = V_{CCIF1} = 8.5\text{V}$ ,  
 $f_{RF} = 98\text{MHz}$ ,  $\text{dev} = 40\text{kHz}$ ,  $f_{MOD} = 1\text{kHz}$ ,  $f_{Xtal} = 10.25\text{MHz}$ , in application circuit, unless  
 otherwise specified).

Item	Symbol	Parameter	Test Conditions	Min.	Typ.	Max.	Unit
5.7	$C_{IN}$	Input capacitance			2.5		pF
<b>6</b>	<b>AGC Time Constant Output</b>						
6.1	$V_{16}$	Max. AGC output voltage	$V_{9-11} = 0\text{mV}_{RMS}$			$V_{REF1} + V_{BE}$	V
6.2	$V_{16}$	Min. AGC output voltage	$V_{9-11} = 50\text{mV}_{RMS}$			0.5	V
6.3	$I_{16}$	Min. AGC charge current	$V_{9-11} = 0\text{mV}_{RMS}, V_{16} = 2.5\text{V}$	-16.5	-12.5	-8.5	$\mu\text{A}$
6.4	$I_{16}$	Max. AGC discharge current	$V_{9-11} = 50\text{mV}_{RMS}, V_{16} = 2.5\text{V}$	0.8	1.25	1.68	mA
<b>7</b>	<b>AGC PIN Diode Driver Output</b>						
7.1	$I_8$	AGC OUT, current min.	$V_{9-11} = 0\text{mV}_{RMS}, V_8 = 2.5\text{V}$		12		$\mu\text{A}$
7.2	$I_8$	AGC OUT, current max.	$V_{9-11} = 50\text{mV}_{RMS}, V_8 = 2.5\text{V}$	-26	-20	-14	mA
<b>8</b>	<b>I/Q Mixer1 (10.7MHz)</b>						
8.1	$R_{IN}$	Input resistance	differential		10		k $\Omega$
8.2	$C_{IN}$	Input capacitance	differential		4		pF
8.3	$R_{OUT}$	Output resistance	differential	100			k $\Omega$
8.4	$V_{9,11}$	Input dc bias		2.2	2.5	2.8	V
8.5	$g_m$	Conversion transconductance			17		ms
8.6	F	Noise figure	400 $\Omega$ generator resistance		3		dB
8.7	$CP_{1dB}$	1dB compression point	referred to diff. mixer input		100		dB $\mu\text{V}$
8.8	IIP3	3rd order intermodulation			122		dB $\mu\text{V}$
8.9	IQP	I/Q phase adjust	PH	-7		+8	$^{\circ}$
8.10	IRR	Image rejection ratio	ratio wanted/image	30	40		dB
8.11	IRR	Image rejection ratio	with phase adjust	40	46		dB
<b>9</b>	<b>IF1 Amplifier1 +2 (10.7MHz)</b>						
9.1	G2	Gain		4.5	6	7.5	dB
9.2	$G_{1min}$	Min. gain	IFG1	7.5	9	10.5	dB
9.3	$G_{1max}$	Max. gain	IFG1	16	18	19.5	dB
9.4	$R_{IN}$	Input resistance		260	330	400	$\Omega$
9.5	$R_{OUT}$	Output resistance		260	330	400	$\Omega$
9.6	$CP_{1dB}$	1dB compression point	referred to 330 $\Omega$ input		105		dB $\mu\text{V}$
9.7	IIP3	3rd order Intermodulation	ref. to 330 $\Omega$ input, 9dB gain		126		dB $\mu\text{V}$
<b>10</b>	<b>Mixer2 (450kHz)</b>						
10.1	$R_{IN}$	Input impedance			330		$\Omega$
10.2	$V_{65}$	Max. input voltage			119		dB $\mu\text{V}$

**Table 5. Electrical characteristics (continued)**

( $T_{amb} = 25^{\circ}\text{C}$ ,  $V_{CC1} = V_{CC2} = V_{CC3} = V_{CCST} = V_{CCVCO} = V_{CCMIX1} = V_{CCMIX2} = V_{CCIF1} = 8.5\text{V}$ ,  
 $f_{RF} = 98\text{MHz}$ ,  $\text{dev} = 40\text{kHz}$ ,  $f_{MOD} = 1\text{kHz}$ ,  $f_{Xtal} = 10.25\text{MHz}$ , in application circuit, unless  
 otherwise specified).

Item	Symbol	Parameter	Test Conditions	Min.	Typ.	Max.	Unit
10.3	$V_{65}$	Limiting sensitivity	S/N = 20dB		28		dB $\mu$ V
10.4	G	Mixer gain			18		dB
<b>11</b>	<b>Limiter 1 (450kHz)</b>						
11.1	$G_{Limiter}$	Gain			80		dB
<b>12</b>	<b>Demodulator, Audio Output</b>						
12.1	THD		Dev.= 75kHz, $V_{65} = 10\text{mV}_{RMS}$			0.1	%
12.2	$V_{MPX}$	MPX output signal	Dev.= 75kHz	350	500	650	$\text{mV}_{RMS}$
12.3	$R_{OUT}$	Output impedance			50	100	$\Omega$
12.4	$ \Delta V _{min}$	DC offset fine adjust	DEM, MENA=1		8.5		mV
12.5	$ \Delta V _{max}$	DC offset fine adjust	DEM, MENA=1		264		mV
12.6	S/N		Dev.= 40kHz, $V_{65} = 10\text{mV}_{RMS}$		76		dB
12.7	$V_{MPXW}$	MPXW output signal	Dev.= 75kHz	300	350	430	$\text{mV}_{RMS}$
<b>13</b>	<b>Quality Detection</b>						
	<b>S-meter, Unweighted Fieldstrength</b>						
13.1	$V_{65}$	Min. input voltage MIX2			30		dB $\mu$ V
13.2	$V_{22}$	Fieldstrength output	$V_{65} = 20\text{dB}\mu\text{V}$		0.1		V
13.3	$V_{22}$	Fieldstrength output	$V_{65} = 119\text{dB}\mu\text{V}$		4.9		V
13.4	$\Delta V_{22}$	voltage per decade	SMSL = 0	0.75	1	1.27	V
13.5	$\Delta V_{22}$	voltage per decade	SMSL = 1	1.1	1.5	1.9	V
13.6	$\Delta V_{22}$	S-meter offset	SL, SMSL=1	-15		15	dB
13.7	$R_{OUT}$	Output impedance		280	400	550	$\Omega$
13.8	TK	Temp coeff.			0		ppm/K
	<b>Adjacent Channel Gain</b>						
13.9	$G_{min}$	Gain minimum	ACG=0		32		dB
13.10	$G_{max}$	Gain maximum	ACG=1		38		dB
	<b>Adjacent Channel Filter</b>						
13.11	$f_{HP}$	-3dB frequency highpass	ACF=0		100		kHz
13.12	$f_{BP}$	Centre frequency	ACF=1		100		kHz
13.13	$f_{-20dB}$	Attenuation 20dB			70		kHz
	<b>Adjacent Channel Output</b>						
13.14	$V_{23}$	Output voltage low			0.1		V
13.15	$V_{23}$	Output voltage high		4.5	4.9		V

**Table 5. Electrical characteristics (continued)**

( $T_{amb} = 25^{\circ}C$ ,  $V_{CC1} = V_{CC2} = V_{CC3} = V_{CCST} = V_{CCVCO} = V_{CCMIX1} = V_{CCMIX2} = V_{CCIF1} = 8.5V$ ,  $f_{RF} = 98MHz$ ,  $dev = 40kHz$ ,  $f_{MOD} = 1kHz$ ,  $f_{Xtal} = 10.25MHz$ , in application circuit, unless otherwise specified).

Item	Symbol	Parameter	Test Conditions	Min.	Typ.	Max.	Unit
13.16	$R_{OUT}$	Output resistance		3.6	4.5	5.4	$k\Omega$
<b>Multipath Channel Gain</b>							
13.17	$G_{min}$	Gain minimum	MPG=0		12		dB
13.18	$G_{max}$	Gain maximum	MPG=1		23		dB
<b>Multipath Bandpass Filter</b>							
13.19	$f_{BP19}$	Centre frequency	MPF=0		19		kHz
13.20	$f_{BP31}$	Centre frequency	MPF=1		31		kHz
13.21	Q	Quality factor		5	8	10	
<b>Multipath Output</b>							
13.22	$V_{24}$	Output voltage low			0.1		V
13.23	$V_{24}$	Output voltage high		4.5	4.9		V
13.24	$R_{OUT}$	Output resistance		2	3	4	$k\Omega$
<b>14</b>	<b>ISS (intelligent Selectivity System)</b>						
<b>Filter 450kHz</b>							
14.1	$f_{centre}$	Centre frequency	$f_{REF\_intern} = 450kHz$		450		kHz
14.2	BW 3dB	Bandwidth, -3dB	ISS80 = 1	70	80	90	kHz
14.3	BW 20dB	Bandwidth, -20dB	ISS80 = 1	132	150	168	kHz
14.4	BW 3dB	Bandwidth, -3dB	ISS80 = 0	105	120	135	kHz
14.5	BW 20dB	Bandwidth, -20dB	ISS80 = 0	220	250	280	kHz
14.6	BW 3dB	Bandwidth weather band	ISS30 = 1	20	30	40	kHz
14.7	BW 20dB	-20dB weather band	ISS30 = 1	56	80	104	kHz
<b>Adjacent Channel ISS Filter Threshold</b>							
14.8	$V_{NTH}$	Internal low threshold	ACNTH		0		V
14.9	$V_{NTH}$	Internal high threshold	ACNTH	0.2	0.3	0.4	V
14.10	$V_{WTH}$	Internal low threshold	ACWTH		0.25	0.35	V
14.11	$V_{WTH}$	Internal high threshold	ACWTH	0.65	0.95	1.3	V
<b>Multipath Threshold</b>							
14.12	$V_{THMP}$	Internal low threshold	MPTH	0.3	0.50	0.7	V
14.13	$V_{THMP}$	Internal high threshold	MPTH	0.65	1.25	1.55	V
<b>ISS Filter Time Constant</b>							
14.14	$I_{27}, I_{28}$	Charge current low mid	TISS, ISSCTL = 1	-96	-74	-54	$\mu A$
14.15	$I_{27}, I_{28}$	Charge current high mid	TISS, ISSCTL = 1		-60		$\mu A$
14.16	$I_{27}, I_{28}$	Charge current low narrow	TISS, ISSCTL = 1	-165	-124	-87	$\mu A$

**Table 5. Electrical characteristics (continued)**

( $T_{amb} = 25^{\circ}\text{C}$ ,  $V_{CC1} = V_{CC2} = V_{CC3} = V_{CCST} = V_{CCVCO} = V_{CCMIX1} = V_{CCMIX2} = V_{CCIF1} = 8.5\text{V}$ ,  
 $f_{RF} = 98\text{MHz}$ ,  $dev = 40\text{kHz}$ ,  $f_{MOD} = 1\text{kHz}$ ,  $f_{Xtal} = 10.25\text{MHz}$ , in application circuit, unless  
 otherwise specified).

Item	Symbol	Parameter	Test Conditions	Min.	Typ.	Max.	Unit
14.17	$I_{27}, I_{28}$	Charge current high narrow	TISS, ISSCTL = 1		-110		$\mu\text{A}$
14.18	$I_{27}, I_{28}$	Discharge current low	TISS, ISSCTL = 0	0.4	1	2	$\mu\text{A}$
14.19	$I_{27}, I_{28}$	Discharge current high	TISS, ISSCTL = 0	10	15	20	$\mu\text{A}$
14.20	$V_{27}, V_{28}$	Low voltage	ISSCTL = 0		0.1	0.2	V
14.21	$V_{27}, V_{28}$	High voltage	ISSCTL = 1	4.6	4.9		V
<b>ISS Filter Switch Threshold</b>							
14.22	$V_{27}, V_{28}$	Threshold ISS on	ISSCTL = 0		3		V
14.23	$V_{27}, V_{28}$	Threshold ISS off	ISSCTL = 0		1		V
14.24	$V_{27}, V_{28}$	Threshold ISS narrow on	ISSCTL = 0		4		V
14.25	$V_{27}, V_{28}$	Threshold ISS narrow off	ISSCTL = 0		2		V
14.26	$I_3$	Charge current low	TDEV		-15		$\mu\text{A}$
14.27	$I_3$	Charge current high	TDEV	-20	-30	-40	$\mu\text{A}$
14.28	$I_3$	Discharge current low	TDEV	0.4	1	2	$\mu\text{A}$
14.29	$I_3$	Discharge current high	TDEV	10	15	20	$\mu\text{A}$
14.30	$DEV_{WTH}$	Internal low threshold	DWTH		30		kHz
14.31	$DEV_{WTH}$	Internal high threshold	DWTH		75		kHz
14.32	$RATIO_{min}$	Referred to threshold	DTH		1		
14.33	$RATIO_{max}$	Referred to threshold	DTH		1.5		
<b>15</b>	<b>Softmute</b>						
15.1	$V_{ANT}$	Upper startpoint	SMTH, SMD, SLOPE = 0		10		$\text{dB}\mu\text{V}$
15.2	$V_{ANT}$	lower startpoint	SMTH, SMD, SLOPE = 0		3		$\text{dB}\mu\text{V}$
15.3	$a_{SMmin}$	Min. softmute depth	SMD, SLOPE = 0, $SMTH_{Upper}$		18		dB
15.4	$a_{SMmax}$	Max. softmute depth	SMD, SLOPE = 0, $SMTH_{Upper}$		36		dB
15.5	$a_{SMTHISS}$	Mute depth threshold for ISS filter on	SMCTH	0.2	1	2	dB
15.6	$V_{ACTH}$	Internal AC mute threshold	ACM	60		340	mV
15.7	$a_{SMAC}$	AC mute depth	ACMD	4		10	dB
15.8	$I_{49}$	Charge current		-65	-47.5	-30	$\mu\text{A}$
15.9	$I_{49}$	Discharge current		11.5	2.5	4	$\mu\text{A}$
<b>16</b>	<b>S/N MPX</b>						
16.1	(S+N)/N		$V_{ANT} = 60\text{dB}\mu\text{V}$ , $dev = 40\text{kHz}$ , $LP = 15\text{kHz}$ deemphasis $t = 50\mu\text{s}$	66	69		dB

### 3.2.3 AM section

**Table 6. Electrical Characteristics**

( $T_{amb} = 25^{\circ}\text{C}$ ,  $V_{CC1} = V_{CC2} = V_{CC3} = V_{CCST} = V_{CCVCO} = V_{CCMIX1} = V_{CCMIX2} = V_{CCIF1} = 8.5\text{V}$ ,  $f_{RF} = 98\text{MHz}$ ,  $m = 30\%$ ,  $f_{MOD} = 400\text{kHz}$ ,  $f_{Xtal} = 10.25\text{MHz}$ , in application circuit, unless otherwise specified).

Item	Symbol	Parameter	Test Conditions	Min.	Typ.	Max.	Unit
<b>17</b>	<b>Global</b>						
17.1	$V_{ANT\_us}$	Usable sensitivity	(S+N)/N = 26 dB	25	19		$\text{dB}\mu\text{V}$
17.2	$\Delta V_{ANT}$	IF2 AGC Range	Ref.: $V_{INRF} = 60\text{dB}\mu\text{V}$ ,	50	52		dB
17.3	(S+N)/N	Signal to Noise Ratio	Ref.: $V_{INRF} = 60\text{dB}\mu\text{V}$	50	55		dB
17.4	$a_{IF}$	IF rejection	Ref.: $V_{INRF} = 60\text{dB}\mu\text{V}$ , IF = 10.7MHz	70	80		dB
17.5	$f_{AF}$	Frequency response	Ref.: $V_{INRF} = 60\text{dB}\mu\text{V}$ , $\Delta V_{AF} = -3\text{ dB}$		3.6		kHz
17.6	THD	Total Harmonic Distortion	$V_{INRF} = 60\text{dB}\mu\text{V}$ , $m = 0.8$ $m = 0.3$ $V_{INRF} = 120\text{ dB}\mu\text{V}$ , $m = 0.8$ $m = 0.3$		0.5 0.3 1.0 0.3		%
17.7	$V_{53}$	AF output level	$V_{INRF} = 60\text{dB}\mu\text{V}$	152	190	228	$\text{mV}_{RMS}$
17.8	$V_{24}$	IF output level	$V_{INRF} = 60\text{dB}\mu$ , $m=\text{off}$		190		$\text{mV}_{RMS}$
17.9	$V_4$	Min. RF AGC threshold Max. RF AGC threshold	WAGC		90 109		$\text{dB}\mu\text{V}$ $\text{dB}\mu\text{V}$
17.10	$V_{71}$	Min. IF AGC threshold Max. IF AGC threshold	WAGC		90 109		$\text{dB}\mu\text{V}$ $\text{dB}\mu\text{V}$
17.11	$V_{71}$	Min. DAGC threshold Max. DAGC threshold	DAGC		74 96		$\text{dB}\mu\text{V}$ $\text{dB}\mu\text{V}$
17.12	$ I_{78max} $	AGC2 charge current	seek	80	100	130	$\mu\text{A}$
17.13	CCR	Charge current ratio	seek/seek off		30		
<b>18</b>	<b>AGC Voltage Driver Output</b>						
18.1	$V_6$	Max. AGC output voltage		3.5			V
18.2	$V_6$	Min. AGC output voltage				0.5	V
18.3	$ I_6 $	AGC current			100		$\mu\text{A}$
<b>19</b>	<b>AGC PIN Diode Driver Output</b>						
19.1	$I_7$	AGC driver current		-2.6	-2	-1.4	mA
<b>20</b>	<b>AM Mixer1 (10.7MHz)</b>						
20.1	$R_{IN}$	Input resistance	differential	100			$\text{k}\Omega$
20.2	$C_{IN}$	Input capacitance	differential		4		pF
20.3	$R_{OUT}$	Output impedance	differential	100			$\text{k}\Omega$

**Table 6. Electrical Characteristics**

( $T_{amb} = 25^{\circ}\text{C}$ ,  $V_{CC1} = V_{CC2} = V_{CC3} = V_{CCST} = V_{CCVCO} = V_{CCMIX1} = V_{CCMIX2} = V_{CCIF1} = 8.5\text{V}$ ,  
 $f_{RF} = 98\text{MHz}$ ,  $m = 30\%$ ,  $f_{MOD} = 400\text{kHz}$ ,  $f_{xtal} = 10.25\text{MHz}$ , in application circuit, unless  
 otherwise specified).

Item	Symbol	Parameter	Test Conditions	Min.	Typ.	Max.	Unit
20.4	CP <sub>1dB</sub>	1dB compression point	referred to diff. mixer input		112		dB $\mu\text{V}$
20.5	IIP3	3rd order intermodulation			132		dB $\mu\text{V}$
20.6	F	Noise figure			8		dB
20.7	A	Gain		23	26	29	dB
20.8	C <sub>min</sub>	Min. capacitance step	IF1T		0.55		pF
20.9	C <sub>max</sub>	Max. capacitance	IF1T		8.25		pF
20.10	C <sub>1-80</sub>		IF1T		2		pF
<b>21</b>	<b>AM Mixer2 (450kHz)</b>						
21.1	R <sub>71</sub>	Input resistance			330		$\Omega$
21.2	C <sub>71</sub>	Input capacitance			2.5		pF
21.3	CP <sub>1dB</sub>	1dB compression point	referred to diff. mixer input		120		dB $\mu\text{V}$
21.4	IIP3	3rd order intermodulation			132		dB $\mu\text{V}$
21.5	F	Noise figure			12		dB
21.6	A	Max. gain	Mixer2 tank output		34		dB
21.7	$\Delta A$	Gain control range			20		dB
21.8	C <sub>min</sub>	Min. cap step	IF2T		1.6		pF
21.9	C <sub>max</sub>	Max. cap	IF2T		24		pF
21.10	C <sub>62-63</sub>		IF2T		2		pF
<b>22</b>	<b>IF Noise Blanking</b>						
22.1	t <sub>bl</sub>	Min. blanking time			8		$\mu\text{s}$
22.2	t <sub>bl</sub>	Max. blanking time			17		$\mu\text{s}$
22.3	V <sub>th</sub>	Min internal threshold		-30	0	30	mV
22.4	V <sub>th</sub>	Max. internal threshold		150	200	250	mV
22.5	V <sub>thstep</sub>	Threshold step		5	15	25	mV
22.6	V <sub>desth</sub>	Min. desensitivity threshold		2	2.2	2.4	V
22.7	V <sub>desth</sub>	Max. desensitivity threshold		3.6	4	4.4	V

### 3.2.4 Stereodecoder

**Table 7. Electrical characteristics**

( $T_{amb} = 25^{\circ}\text{C}$ ,  $V_{CC1} = V_{CC2} = V_{CC3} = V_{CCST} = V_{CCVCO} = V_{CCMIX1} = V_{CCMIX2} = V_{CCIF1} = 8.5\text{V}$ ,  $V_{MPX} = 500\text{mV}_{\text{rms mono}}$ ,  $f = 1\text{kHz}$ , deemphasis =  $50\mu\text{s}$ ,  $f_{\text{xtal}} = 10.25\text{MHz}$ , in application circuit, unless otherwise specified).

Item	Symbol	Parameter	Test Conditions	Min.	Typ.	Max.	Unit
<b>23</b>	<b>Stereodecoder</b>						
23.1	$V_{in}$	MPX input level	STD Gain = 2,5 dB		0.5	0.93	$V_{\text{rms}}$
23.2	$R_{in}$	Input resistance		70	100	130	$k\Omega$
23.3	$G_{\text{min}}$	Min. Stereodecoder gain		-0.5	0	0.5	dB
23.4	$G_{\text{max}}$	Max. Stereodecoder gain		3.15	3.75	4.35	dB
23.5	$G_{\text{step}}$	Stereodecoder gain step resolution		1	1.25	1.5	dB
23.6	SVRR	Supply voltage ripple rejection	Vripple = 100mV, f = 1kHz	56	60		dB
23.7	a	Max. channel separation	$V_{MPX} = 500\text{mV}_{\text{rms stereo}}$ only L/R		50		dB
23.8	THD	Total harmonic distortion			0.02	0.3	%
23.9	(S+N)/N	Signal plus Noise to Noise ratio	A-weighted, 19kHz notch		85		dB
23.10	$V_{\text{puafs}}$	Pull up voltage for AFS pin			3.3		V
23.11	$R_{\text{puafs}}$	Pull up resistor for AFS pin			25		$k\Omega$
23.12	$V_{\text{TH1}}$	1. threshold for AFS PIN		2.2	2.4	2.6	V
23.13	$V_{\text{TH2}}$	2. threshold for AFS PIN		0.6	0.8	1.0	V
<b>24</b>	<b>Mono/Stereo-switch</b>						
24.1	$V_{\text{PTHST1}}$	Pilot threshold voltage	for Mono->Stereo, PTH = 1	5.5	10	15.5	$\text{mV}_{\text{rms}}$
24.2	$V_{\text{PTHST0}}$	Pilot threshold voltage	for Mono->Stereo, PTH = 0	9	14	19	$\text{mV}_{\text{rms}}$
24.3	$V_{\text{PTHMO1}}$	Pilot threshold voltage	for Stereo->Mono, PTH = 1	4	8	12	$\text{mV}_{\text{rms}}$
24.4	$V_{\text{PTHMO0}}$	Pilot threshold voltage	for Stereo->Mono, PTH = 0	7	12	16	$\text{mV}_{\text{rms}}$
<b>25</b>	<b>19kHz PLL</b>						
25.1	$f_{\text{lock}}$	PLL lock range	Pilot magnitude $20\text{mV}_{\text{rms}} = 4\%$	18.9		19.1	kHz
25.2	DP	Pilot deviation	Pilot frequency 19kHz	4		30	%
<b>26</b>	<b>Deemphasis- and highcut</b>						
26.1	$t_{\text{HC50}}$	Deemphasis time constant	DEEMP = 0, DESFT = 1 $V_{\text{LEVEL}} \gg V_{\text{HCH}}$		50		$\mu\text{s}$
26.2	$t_{\text{HC75}}$	Deemphasis time constant	DEEMP = 1, DESFT = 1 $V_{\text{LEVEL}} \gg V_{\text{HCH}}$		75		$\mu\text{s}$



**Table 7. Electrical characteristics (continued)**

( $T_{amb} = 25^{\circ}\text{C}$ ,  $V_{CC1} = V_{CC2} = V_{CC3} = V_{CCST} = V_{CCVCO} = V_{CCMIX1} = V_{CCMIX2} = V_{CCIF1} = 8.5\text{V}$ ,  
 $V_{MPX} = 500\text{mV}_{\text{rms}}$  mono,  $f = 1\text{kHz}$ , deemphasis =  $50\mu\text{s}$ ,  $f_{\text{xtal}} = 10.25\text{MHz}$ , in application  
circuit, unless otherwise specified).

Item	Symbol	Parameter	Test Conditions	Min.	Typ.	Max.	Unit
26.3	$t_{\text{HC25}}$	Deemphasis time constant	DEEMP = 0, DESFT = 0 $V_{\text{LEVEL}} \gg V_{\text{HCH}}$		25		$\mu\text{s}$
26.4	$t_{\text{HC37}}$	Deemphasis time constant	DEEMP = 1, DESFT = 0 $V_{\text{LEVEL}} \gg V_{\text{HCH}}$		37.5		$\mu\text{s}$
26.5	$t_{\text{HC50}}$	Highcut time constant	DEEMP = 0, DESFT = 1 $V_{\text{LEVEL}} \ll V_{\text{HCL}}$		150		$\mu\text{s}$
26.6	$t_{\text{HC75}}$	Highcut time constant	DEEMP = 1, DESFT = 1 $V_{\text{LEVEL}} \ll V_{\text{HCL}}$		225		$\mu\text{s}$
26.7	$F_{\text{AMCMin}}$	Min. AM corner frequency	DEEMP = 0, DESFT = 1 AMCF		1.06		kHz
26.8	$F_{\text{AMCMin}}$	Max. AM corner frequency	DEEMP = 0, DESFT = 1 AMCF		3.18		kHz
<b>27</b>	<b>Stereoblend- and highcut-control</b>						
27.1	$L_{\text{Gmin}}$	Min. level gain	LG	-0.5	0	0.5	dB
27.2	$L_{\text{Gmax}}$	Max. level gain	LG	4	4.7	5.2	dB
27.3	$L_{\text{Gstep}}$	Level gain step resolution	LG	0.4	0.67	0.8	dB
27.4	$\text{VSBL}_{\text{min}}$	Min. voltage for mono	SBC		29	33	$\%V_{\text{REF1}}$
27.5	$\text{VSBL}_{\text{max}}$	Max. voltage for mono	SBC	54	58		$\%V_{\text{REF1}}$
27.6	$\text{VSBL}_{\text{step}}$	Step resolution	SBC		4.2		$\%V_{\text{REF1}}$
27.7	$\text{VHCH}_{\text{min}}$	Min. voltage for no highcut	VHCH		42	46	$\%V_{\text{REF1}}$
27.8	$\text{VHCH}_{\text{max}}$	Max. Voltage for no highcut	VHCH	61	66		$\%V_{\text{REF1}}$
27.9	$\text{VHCH}_{\text{step}}$	Step resolution	VHCH		8		$\%V_{\text{REF1}}$
27.10	$\text{VHCL}_{\text{min}}$	Min. voltage for full high cut	VHCL, MAXHC = 00		11	15	$\%V_{\text{HCH}}$
27.11	$\text{VHCL}_{\text{max}}$	Max. voltage for full high cut	VHCL, MAXHC = 00	31	33		$\%V_{\text{HCH}}$
27.12	$\text{VHCL}_{\text{step}}$	Step resolution	VHCL, MAXHC = 00		7.3		$\%V_{\text{HCH}}$
<b>28</b>	<b>Carrier and harmonic suppression at the output</b>						
28.1	a19	Pilot signal $f=19\text{kHz}$	$V_{\text{pilot}} = 50\text{mV}_{\text{rms}}$		50		dB
28.2	a38	Subcarrier $f=38\text{kHz}$			75		dB
28.3	a57	Subcarrier $f=57\text{kHz}$			62		dB
28.4	a76	Subcarrier $f=76\text{kHz}$			90		dB
<b>29</b>	<b>Intermodulation (Note 1)</b>						
29.1	a2	$f_{\text{mod}}=10\text{kHz}$ , $f_{\text{spur}}=1\text{kHz}$			65		dB
29.2	a3	$f_{\text{mod}}=13\text{kHz}$ , $f_{\text{spur}}=1\text{kHz}$			75		dB

**Table 7. Electrical characteristics (continued)**

( $T_{amb} = 25^{\circ}\text{C}$ ,  $V_{CC1} = V_{CC2} = V_{CC3} = V_{CCST} = V_{CCVCO} = V_{CCMIX1} = V_{CCMIX2} = V_{CCIF1} = 8.5\text{V}$ ,  
 $V_{MPX} = 500\text{mV}_{\text{rms}}$  mono,  $f = 1\text{kHz}$ , deemphasis =  $50\mu\text{s}$ ,  $f_{\text{Xtal}} = 10.25\text{MHz}$ , in application  
circuit, unless otherwise specified).

Item	Symbol	Parameter	Test Conditions	Min.	Typ.	Max.	Unit
<b>30</b>	<b>Traffic Radio (Note 2)</b>						
30.1	a57	Signal f=57kHz			70		dB
<b>31</b>	<b>SCA - Subsidiary Communications Authorization (Note 3)</b>						
31.1	a67	Signal f=67kHz			75		dB
<b>32</b>	<b>ACI - Adjacent Channel Interference (Note 4)</b>						
32.1	a114	Signal f=114kHz			95		dB
32.2	a190	Signal f=190kHz			84		dB
<b>33</b>	<b>FM noise blanker</b>						
33.1	$V_{\text{TRMIN}}$	Min. trigger threshold <sup>0)</sup>	$V_{\text{PEAK}}=0.8\text{V}$ , NBLTH		147		$\text{mV}_{\text{OP}}$
33.2	$V_{\text{TRMAX}}$	Max. trigger threshold <sup>0)</sup>	$V_{\text{PEAK}}=0.8\text{V}$ , NBLTH		280		$\text{mV}_{\text{OP}}$
33.3	$V_{\text{TRSTEP}}$	Trigger threshold step <sup>0)</sup>			19		$\text{mV}_{\text{OP}}$
33.4	$V_{\text{TRNOISE}}$	Min. noise controlled trigger threshold <sup>0)</sup>	$V_{\text{PEAK}}=1.5\text{V}$ , NBCTH		450		$\text{mV}_{\text{OP}}$
33.5	$V_{\text{TRNOISE}}$	Max. noise controlled trigger threshold <sup>0)</sup>	$V_{\text{PEAK}}=1.5\text{V}$ , NBCTH		1200		$\text{mV}_{\text{OP}}$
33.6	$V_{\text{PEAK}}$	Peak voltage	NBRR = 00, $V_{\text{MPX}}=0\text{mV}$	0.5	0.8	1	V
33.7	$V_{\text{PEAK}}$	Peak voltage	$V_{\text{MPX}}=50\text{mV}$ , f=150kHz	1.6	1.9	2.1	V
33.8	$V_{\text{PEAK}}$	Peak voltage	$V_{\text{MPX}}=200\text{mV}$ , f=150kHz	2.3	2.5	2.7	V
33.9	$V_{\text{PEAKDEV}}$	Min. deviation dependent peak voltage	$V_{\text{MPX}}=800\text{mV}$ , NBDTH = 11	0.5	0.8 (off)	1	$V_{\text{OP}}$
33.10	$V_{\text{PEAKDEV}}$	Max. deviation dependent peak voltage	$V_{\text{MPX}}=800\text{mV}$ , NBDTH= 00	2.0	2.3	2.6	$V_{\text{OP}}$
33.11	$V_{\text{PEAKFS}}$	Min. fieldstrength controlled peak voltage	$V_{\text{MPX}}=0\text{mV}$ , $V_{\text{LEVEL}} \ll V_{\text{SBL}}$ (fully mono), NBFS = 11	0.5	0.8 (off)	1	V
33.12	$V_{\text{PEAKFS}}$	Max. fieldstrength controlled peak voltage	$V_{\text{MPX}}=0\text{mV}$ , $V_{\text{LEVEL}} \ll V_{\text{SBL}}$ (fully mono), NBFS = 00	1.7	2.0	2.1	V
33.13	$T_{\text{S}}$	Min. blanking time	Signal HOLDN in testmode, NBT		22		$\mu\text{s}$
33.14	$T_{\text{S}}$	Max. blanking time	Signal HOLDN in testmode, NBT		38		$\mu\text{s}$
33.15	$\text{SR}_{\text{PEAK}}$	Noise rectifier charge	Signal PEAK in testmode, NBPC=0		10		$\text{mV}/\mu\text{s}$
33.16	$\text{SR}_{\text{PEAK}}$	Noise rectifier charge	Signal PEAK in testmode, NBPC=1		20		$\text{mV}/\mu\text{s}$

**Table 7. Electrical characteristics (continued)**

( $T_{amb} = 25^{\circ}\text{C}$ ,  $V_{CC1} = V_{CC2} = V_{CC3} = V_{CCST} = V_{CCVCO} = V_{CCMIX1} = V_{CCMIX2} = V_{CCIF1} = 8.5\text{V}$ ,  
 $V_{MPX} = 500\text{mV}_{\text{rms}}$  mono,  $f = 1\text{kHz}$ , deemphasis =  $50\mu\text{s}$ ,  $f_{\text{Xtal}} = 10.25\text{MHz}$ , in application  
circuit, unless otherwise specified).

Item	Symbol	Parameter	Test Conditions	Min.	Typ.	Max.	Unit
33.17	$V_{\text{RECTADJ}}$	Noise rectifier discharge adjustment	Signal PEAK in testmode, NBRR=00, NBSMP=0, MPPC=0		0.3		V/ms
33.18	$V_{\text{RECTADJ}}$	Noise rectifier discharge adjustment	Signal PEAK in testmode, NBRR=01, NBSMP=0, MPPC=0		0.8		V/ms
33.19	$V_{\text{RECTADJ}}$	Noise rectifier discharge adjustment	Signal PEAK in testmode, NBRR=10, NBSMP=0, MPPC=0		1.3		V/ms
33.20	$V_{\text{RECTADJ}}$	Noise rectifier discharge adjustment	Signal PEAK in testmode, NBRR=11, NBSMP=0, MPPC=0		2.0		V/ms
33.21	$V_{\text{ADJMP}}$	Noise rectifier adjustment by multipath	Signal PEAK in testmode, $V_{\text{MPTC}}=1\text{V}$ , NBRR=01, MPPC=1		2.5		V/ms
33.22	$V_{\text{ADJMP}}$	Noise rectifier adjustment by strong multipath influence	Signal PEAK in testmode, $V_{\text{MPTC}}=1\text{V}$ , NBRR=01, MPPC=0		3.3		V/ms
33.23	$V_{\text{ADJMP}}$	Noise rectifier adjustment by multipath and strong multipath influence	Signal PEAK in testmode, $V_{\text{MPTC}}=1\text{V}$ , NBRR=01, MPPC=1		4.5		V/ms
33.24	$G_{\text{AMdelay}}$	AM delay filter attenuation	$f = 2.2\text{kHz}$		2		dB
<b>34</b>	<b>Multipath Detector</b>						
34.1	$f_{\text{CMP}}$	Center frequency of multipath-bandpass	stereo decoder locked on pilot tone		19		kHz
34.2	$G_{\text{BPMP}}$	Min. band pass gain	MPBPG	4	6	8	dB
34.3	$G_{\text{BPMP}}$	Max. band pass gain	MPBPG	9	12	15	dB
34.4	$G_{\text{RECTMP}}$	Min. rectifier gain	MPRG	-1	0	1	dB
34.5	$G_{\text{RECTMP}}$	Max. rectifier gain	MPRG	4.5	7.6	9.5	dB
34.6	$I_{\text{CHMP}}$	Rectifier charge current	MPCC = 0	0.5	0.8	1.2	$\mu\text{A}$
34.7	$I_{\text{CHMP}}$	Rectifier charge current	MPCC = 1	0.2	0.4	0.6	$\mu\text{A}$
34.8	$I_{\text{DISMP}}$	Rectifier discharge current		0.3	1	0.8	mA
<b>35</b>	<b>Quality detector</b>						
35.1	a	Min. MP influence factor	QDC	0.5	0.6	0.7	
35.2	a	Max. MP influence factor	QDC	0.9	1.05	1.2	
35.3	A	Min. noise influence factor	QNG		6		dB
35.4	A	Max. noise influence factor	QNG		15		dB

## 1. Intermodulation Suppression

$$a2 = V_O(\text{signal}, @1\text{KHz}) / V_O(\text{spurious}, @1\text{KHz}) ; fs = (2 \times 10\text{KHz}) - 19\text{KHz}$$

$$a3 = V_O(\text{signal}, @1\text{KHz}) / V_O(\text{spurious}, @1\text{KHz}) ; fs = (3 \times 13\text{KHz}) - 38\text{KHz}$$

measured with: 91% stereo signal; 9% pilot signal; fm = 10kHz or 13kHz.

## 2. Traffic Radio (V.F.) Suppression

$$a57(V,W,F) = V_O(\text{signal}, @1\text{KHz}) / V_O(\text{spurious}, @1\text{KHz} \pm 23\text{KHz})$$

measured with: 91% stereo signal; 9% pilot signal; fm=1kHz; 5% sub carrier (f=57kHz, fm=23Hz AM, m=60%)

## 3. SCA ( Subsidiary Communications Authorization )

$$a67 = V_O(\text{signal}, @1\text{KHz}) / V_O(\text{spurious}, @9\text{KHz}) ; fs = (2 \times 38\text{KHz}) - 67\text{KHz}$$

measured with: 81% mono signal; 9% pilot signal; fm=1kHz; 10%SCA – sub carrier ( fs = 67kHz, unmodulated ).

## 4. ACI ( Adjacent Channel Interference )

$$a114 = V_O(\text{signal}, @1\text{KHz}) / V_O(\text{spurious}, @4\text{KHz}) ; fs = 110\text{KHz} - (3 \times 38\text{KHz})$$

$$a190 = V_O(\text{signal}, @1\text{KHz}) / V_O(\text{spurious}, @4\text{KHz}) ; fs = 186\text{KHz} - (5 \times 38\text{KHz})$$

measured with: 90% mono signal; 9% pilot signal; fm=1kHz; 1% spurious signal ( fs = 110kHz or 186kHz, unmodulated).

<sup>0</sup>) All thresholds are measured in Testmode at the quality output. The thresholds are calculated by

$$V_{NBTH} - V_{PEAK}$$

$V_{PEAK}$  is adjusted by applying a 150kHz sinewave at MPXIN.

Figure 3. Trigger threshold vs.  $V_{PEAK}$

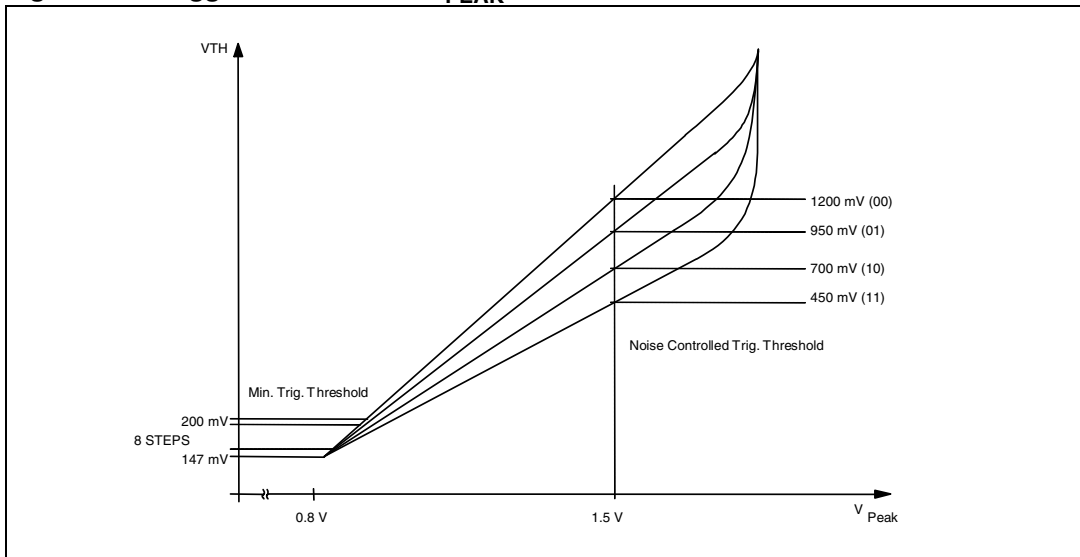

Figure 4. Deviation controlled trigger adjustment

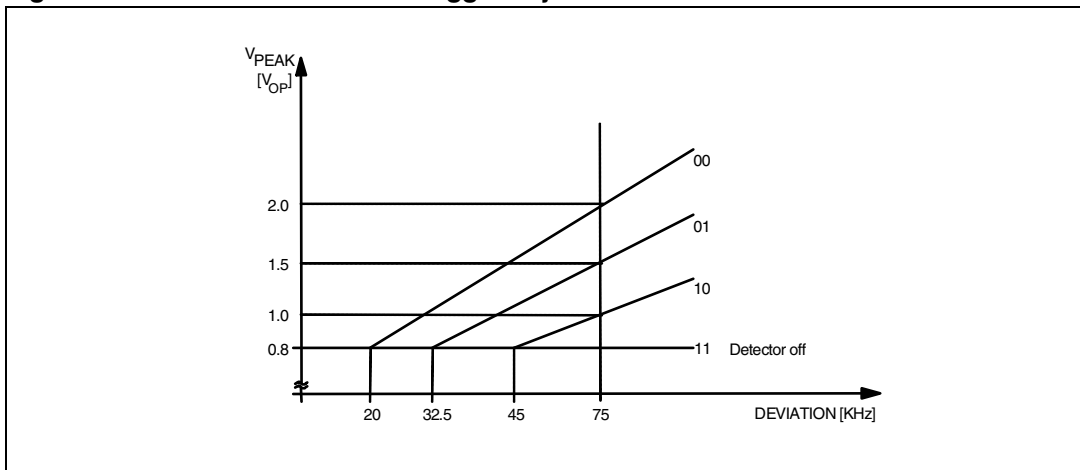
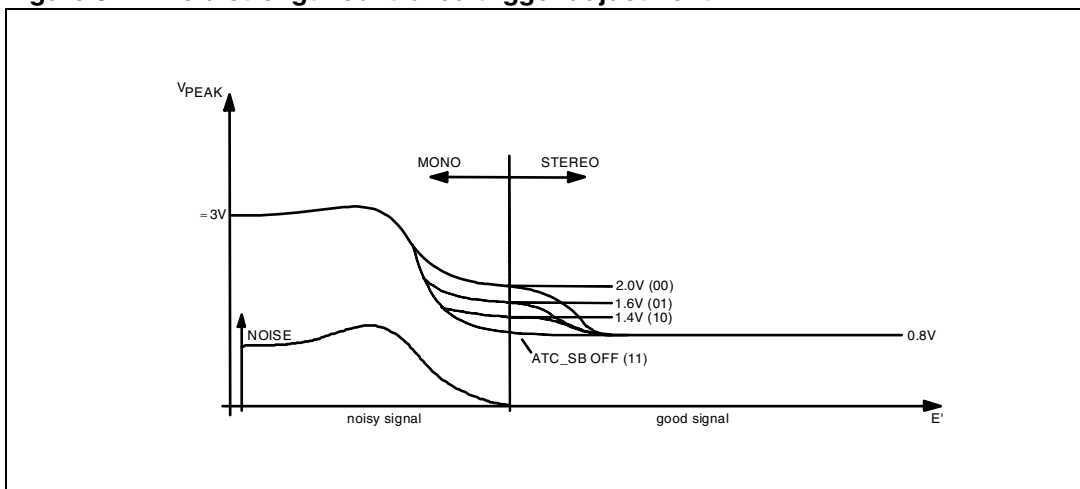

Figure 5. Field strength controlled trigger adjustment



### 3.2.5 PLL section

**Table 8. Electrical characteristics**

( $T_{amb} = 25^{\circ}\text{C}$ ,  $V_{CC1} = V_{CC2} = V_{CC3} = V_{CCST} = V_{CCVCO} = V_{CCMIX1} = V_{CCMIX2} = V_{CCIF1} = 8.5\text{V}$ ,  $f_{RF} = 98\text{MHz}$ , dev. = 40kHz,  $f_{MOD} = 1\text{kHz}$ ,  $f_{Xtal} = 10.25\text{MHz}$ , in application circuit, unless otherwise specified).

Item	Symbol	Parameter	Test Conditions	Min.	Typ.	Max.	Unit
<b>36</b>	<b>Output of Tuning Voltages (TV1,TV2)</b>						
36.1	$V_{OUT}$	Output voltage	TVO	0.5		$V_{CC3}-0.5$	V
36.2	$R_{OUT}$	Output impedance	TVMODE=0	32	40	48	k $\Omega$
36.3	$R_{OUT}$	Output impedance	TVMODE=1	16	20	24	k $\Omega$
<b>37</b>	<b>Xtal Reference Oscillator</b>						
37.1	$f_{LO}$	Reference frequency	$C_{Load} = 15\text{pF}$		10.25		MHz
37.2	$C_{Step}$	Min. cap step	XTAL		0.75		pF
37.3	$C_{max}$	Max. cap	XTAL		23.25		pF
37.4	$\Delta f/f$	Deviation versus $V_{CC2}$	$\Delta V_{CC2} = 1\text{V}$		1.5		ppm/V
37.5	$\Delta f/f$	Deviation versus temp	$-40^{\circ}\text{C} < T < +85^{\circ}\text{C}$		0.2		ppm/K
<b>38</b>	<b>Loop Filter Input/Output</b>						
38.1	$-I_{IN}$	Input leakage current	$V_{IN} = \text{GND}$ , $PD_{OUT} = \text{Tristate}$	-0.1		0.1	$\mu\text{A}$
38.2	$I_{IN}$	Input leakage current	$V_{IN} = V_{REF1}$ $PD_{OUT} = \text{Tristate}$	-0.1		0.1	$\mu\text{A}$
38.3	$V_{OL}$	Output voltage Low	$I_{OUT} = -0.2\text{mA}$		0.05	0.5	V
38.4	$V_{OH}$	Output voltage High	$I_{OUT} = 0.2\text{mA}$	$V_{CC3}-0.5$	$V_{CC3}-0.05$		V
38.5	$I_{OUT}$	Output current, sink	$V_{OUT} = 1\text{V to } V_{CC3}-1\text{V}$			10	mA
38.6	$I_{OUT}$	Output current, source	$V_{OUT} = 1\text{V to } V_{CC3}-1\text{V}$	-10			mA
<b>39</b>	<b>Voltage Controlled Oscillator (VCO)</b>						
39.1	$f_{VCOmin}$	Minimum VCO frequency		50			MHz
39.2	$f_{VCOmax}$	Maximum VCO frequency				260	MHz
39.3	C/N	Carrier to Noise	$f_{VCO} = 200\text{MHz}$ , $\Delta f = 1\text{KHz}$ , $B = 1\text{Hz}$ , closed loop		80		dBc
<b>40</b>	<b>SSTOP, INLOCK, ISSSTATUS Outputs (Open Collector)</b>						
40.1	V	Output voltage low	$I = -200\mu\text{A}$		0.2	0.5	V
40.2	V	Output voltage high				5	V
40.3	-I	Output leakage current	$V = 5\text{V}$	-0.1		0.1	$\mu\text{A}$
40.4	I	Output current, sink	$V = 0.5\text{V}-5\text{V}$			1	mA
<b>41</b>	<b>Switching Outputs S1, S2 (Open Collector SMODE=1)</b>						
41.1	V	Output voltage low	$I = -5\text{mA}$		0.2	0.5	V

**Table 8. Electrical characteristics (continued)**

( $T_{amb} = 25^{\circ}\text{C}$ ,  $V_{CC1} = V_{CC2} = V_{CC3} = V_{CCST} = V_{CCVCO} = V_{CCMIX1} = V_{CCMIX2} = V_{CCIF1} = 8.5\text{V}$ ,  $f_{RF} = 98\text{MHz}$ , dev. = 40kHz,  $f_{MOD} = 1\text{kHz}$ ,  $f_{Xtal} = 10.25\text{MHz}$ , in application circuit, unless otherwise specified).

Item	Symbol	Parameter	Test Conditions	Min.	Typ.	Max.	Unit
41.2	V	Output voltage high				$V_{CC1}$	V
41.3	-I	Output leakage current	$V = 5\text{V}$	-3		3	$\mu\text{A}$
41.4	I	Output current, sink	$V = 0.5\text{V} - V_{CC}$	5	10	13	mA
<b>42</b>	<b>Switching Outputs S1, S2 (Open Emitter SMODE=0)</b>						
42.1	V	Output voltage low	$I = 0\mu\text{A}$		0		V
42.2	V	Output voltage high	$I = 1\text{mA}$		$V_{CC1} - 1$		V
42.3	-I	Output leakage current		-0.1		0.1	$\mu\text{A}$
42.4	I	Output current, sink	$V = 5\text{V}$	5	9.5	11.5	mA

## 4 Functional description

### 4.1 FM section

#### 4.1.1 Mixer1, AGC and 1.IF

FM quadrature I/Q-mixer converts FM RF to IF1 of 10.7MHz. The mixer provides inherent image rejection and wide dynamic range with low noise and large input signal performance. The mixer1 tank can be adjusted by software (IF1T). For accurate image rejection the phase-error of I/Q can be compensated by software (PH)

It is capable of tuning the US FM, US weather, Europe FM, Japan FM and East Europe FM bands

- US FM = 87.9 to 107.9 MHz
- US weather = 162.4 to 162.55 MHz
- Europe FM = 87.5 to 108 MHz
- Japan FM = 76 to 91 MHz
- East Europe FM = 65.8 to 74 MHz

The AGC operates on different sensitivities and bandwidths in order to improve the input sensitivity and dynamic range. AGC thresholds are programmable by software (RFAGC,IFAGC,KAGC). The output signal is a controlled current for pin diode attenuator.

A 10.7MHz programmable amplifier (IFG1) correct the IF ceramic insertion loss and the costumer level plan application.

#### 4.1.2 Mixer2, limiter and demodulator

In this 2nd mixer stage the first 10.7MHz IF is converted into the second 450kHz IF. A multi-stage limiter generates signals for the complete integrated demodulator including spike cancellation (DNB). MPX output DC offset versus noise DC level is correctable by software (DEM), if tuner softmute is activated.

#### 4.1.3 Quality detection and ISS

##### Fieldstrength

Parallel to mixer2 input a 10.7MHz limiter generates a signal for digital IF counter and a fieldstrength output signal. This internal unweighted fieldstrength is used for keying AGC, adjacent channel and multipath detection and is available at PIN22 (FSU) after +6dB buffer stage. It is possible to combine the IF counter result with this FSU via programmable comparator (SSTH). The behaviour of FSU signal can be corrected for DC offset (SL) and slope (SMSL). The generated unweighted fieldstrength is externally filtered and used for softmute function and generation of ISS filter switching signal for weak input level (sm).

##### Adjacent channel detector

The input of the adjacent channel detector is AC coupled from internal unweighted fieldstrength. A programmable highpass or bandpass (ACF) and amplifier (ACG) as well as rectifier determines the influences. This voltage is compared with adjustable comparator1 thresholds (ACWTH, ACNTH). The output signal of this comparator generates a DC level at PIN27 by programmable time constant. Time control (TISS) for a present adjacent channel



is made by charge and discharge current after comparator1 in an external capacitance. The charge current is fixed and the discharge current is controlled by I<sup>2</sup>C Bus. This level produces digital signals (ac, ac+) in an additional comparator4. The adjacent channel information is available as analog output signal after rectifier and +8dB output buffer.

### Multipath detector

The input of the multipath detector is AC coupled from internal unweighted fieldstrength. A programmable bandpass (MPF) and amplifier (MPG) as well as rectifier determines the influences. This voltage is compared with an adjustable comparator2 thresholds (MPTH). The output signal of this comparator2 is used for the "Milano" effect. In this case the adjacent channel detection is switched off. The "Milano" effect is selectable by I<sup>2</sup>C Bus (MPOFF). The multipath information is available as analog output signal after rectifier and +8dB output buffer.

### 450kHz IF narrow bandpass filter (ISS filter)

The device gets an additional 450KHz IF narrow bandpass filter for suppression of noise and adjacent channel signal influences. This narrow filter has three switchable bandwidths, narrow range of 80kHz, mid range of 120kHz and 30kHz for weather band information. Without ISS filter the IF bandwidth (wide range) is defined only by ceramic filter chain. The filter is located between mixer2 and 450kHz limiter stage. The centre frequency is matched to the demodulator center frequency.

### Deviation detector

In order to avoid distortion in audio output signal the narrow ISS filter is switched OFF for present overdeviation. Hence the demodulator output signal is detected. A lowpass filtering and peak rectifier generates a signal that is defined by software controlled current (TDEV) in an external capacitance.

This value is compared with a programmable comparator3 thresholds (DWTH, DTH) and generates two digital signals (dev, dev+). For weak signal condition deviation threshold is dependent on FSWO.

### ISS switch logic

All digital signals coming from adjacent channel detector, deviation detector and softmute are acting via switching matrix on ISS filter switch. The IF bandpass switch mode is controlled by software (ISSON, ISS30, ISS80, CTLOFF). The switch ON of the IF bandpass is also available by external manipulation of voltage at PIN27. Two application modes are available (APPM).

The conditions are described in table 51.

## 4.1.4 Soft mute control

The filtered fieldstrength (FSWO) signal is the reference for mute control. The startpoint and mute depth are programmable (SMTH, SMD) in a wide range. The time constant is defined by external capacitance. Additional adjacent channel mute function is supported. A highpass filter with -3dB threshold frequency of 100kHz, amplifier and peak rectifier generates an adjacent noise signal from MPX output with the same time constant for softmute. This value is compared with comparator5 thresholds (ACM). For present strong adjacent channel the MPX signal is additional attenuated (ACMD).

## 4.2 AM section

The up/down conversion is combined with gain control circuit sensing three input signals, narrow band information at PIN 54, upconversion signal (IF2AGC) at PIN 71 and wide band information (RFAGC) at PIN 4. This gain control gives two output signals. The first one is a current for pin diode attenuator and the second one is a voltage for preamplifier. Time constant of RF- and IF-AGC is defined by internal 100k resistor and external capacitor at PIN 67. The intervention points for AGC (DAGC, WAGC) are programmable by software.

In order to avoid a misbehaviour of AGC intervention point it is important to know that the DAGC threshold has to be lower than WAGC threshold !

The oscillator frequency for upconversion-mixer1 is generated by dividing the VCO frequency after VCO divider (VCOD) and AM predivider (AMD).

Two 10,7MHz ceramic filters before mixer2 input increases 900KHz attenuation. In mixer2 the IF1 is down converted into the IF2 450kHz. After filtering by ceramic filter a 450kHz amplifier is included with an additional gain control of IF2 below DAGC threshold. Time constant is defined by capacitance at PIN 78.

Mixer1 and mixer2 tanks are software controlled adjustable (IF1T, IF2T).

The demodulator is a peak detector to generate the audio output signal.

A separate output is available for AMIF stereo (AMST).

### AM IF noise blanker

In order to remove in AM short spikes a noise cancellation conception is used in 450KHz IF AM level. The advantage is to avoid long narrow AGC- and demodulator- time constants, which enlarge spike influences on audio signal and makes difficult to remove it in audio path.

The 10,7MHz AM IF signal generates before 10,7 MHz ceramic filter via limitation an unweighted field strength signal including slope of noise spike. The comparison of these detected slope between fast and slow rectifier ignores audio modulation whereby the threshold of slow rectifier is programmable (AINBT). A comparator activates a pulse generator.

The duration of this pulse is software programmable (AINT) and is smooth blanking out the spikes in 450KHz AM mixer2. Additionally this functionality is controlled by narrow AM field strength (AINBD).

## 4.3 Stereodecoder

### 4.3.1 Decoder

The stereo decoder-part of the TDA7540 (see Fig. 14) contains all functions necessary to demodulate the MPX-signal like pilot tone-dependent MONO/STEREO-switching as well as "stereoblend" and "highcut". Adaptations like programmable input gain, roll-off compensation, selectable deemphasis time constant and a programmable field strength input allow easy adaption to different applications.

The 4.th order input filter has a corner frequency of 80kHz and is used to attenuate spikes and noise and acts as an anti-aliasing filter for the following switch capacitor filters.

## Demodulator

In the demodulator block the left and the right channel are separated from the MPX-signal. In this stage also the 19-kHz pilot tone is canceled. For reaching a high channel separation the TDA7540 offers an I<sup>2</sup>C-bus programmable roll-off adjustment, which is able to compensate the low pass behavior of the tuner section. Within the compensation range an adjustment to obtain at least 40dB channel separation is possible. The bits for this adjustment are located together with the level gain adjustment in one byte. This gives the possibility to perform an optimization step during the production of the car radio where the channel separation and the field strength control are trimmed.

In addition to that the FM signal can be inverted.

## Deemphasis and Highcut

The deemphasis low pass allows to choose between a time constant of 50 $\mu$ s/ 75 $\mu$ s (DEEMP) and 25 $\mu$ s/37.5 $\mu$ s (DESFT). The highcut control range will be in both cases  $\tau_{HC} = 2 \times \tau_{Deemp}$ . Inside the highcut control range (between VHCH and VHCL) the LEVEL signal is converted into a 5-bit word, which controls the low pass time constant between  $\tau_{Deemp} \dots 3 \times \tau_{Deemp}$ . Thereby the resolution will remain always 5 bits independently of the absolute voltage range between the VHCH- and VHCL-values.

The highcut function can be switched off by I<sup>2</sup>C-bus .

In AM mode (AMON = 1) the bits DEEMP and DESFT together with the AM corner frequency bits (AMCF1...5) can be used as programmable AM frequency response. The maximum corner frequency is defined by  $\tau_{Deemp}$  , the minimum is defined by  $3 \times \tau_{Deemp}$

## 19kHz PLL and pilot tone detector

The PLL has the task to lock on the 19kHz pilot tone during a stereo-transmission to allow a correct demodulation. The included pilot tone-detector enables the demodulation if the pilot tone reaches the selected pilot tone threshold  $V_{PTHST}$ . Two different thresholds are available. By reading the status byte of the TDA7540 via I<sup>2</sup>C-bus the detector output can be checked.

### Field Strength Control

The field strength input is used to control the highcut- and the stereoblend-function. In addition the signal can be also used to control the noise blanker thresholds and as input for the multipath detector.

## LEVEL-Input and -Gain

As level input for the stereo decoder is used the FSU voltage (pin22). Applying a capacitor at FSTC (pin33) a desired time constant can be reached together with the internal resistor of 10k between FSU pin and FSTC pin.

In addition to that the LEVEL signal is low pass filtered internally in order to suppress undesired high frequency modulation on the highcut- and stereoblend-function . The filter is a combination of a 1.st-order RC-low pass at 53kHz (working as anti-aliasing filter) and a 1.st-order switched capacitor low pass at 2.2kHz. The second stage is a programmable gain stage to adapt the LEVEL signal internally . The gain is widely programmable in 8 steps from 0dB to 4,7dB (step=0.67dB). These 3bits are located together with the Roll-Off bits in the "Stereo decoder 8"-byte to simplify a possible adaptation during the production of the car radio.

### Stereoblend control

The stereoblend control block converts the internal LEVEL-voltage into a demodulator compatible analog signal, which is used to control the channel separation between 0dB and the maximum separation. Internally this control range has a fixed upper limit, which is the internal reference voltage  $V_{REF1}$ . The lower limit can be programmed between 29 and 58% of  $V_{REF1}$  in 4% steps (see fig.6).

To adjust the external LEVEL-voltage to the internal range two values must be defined: the LEVEL gain  $L_G$  and VSBL. To adjust the voltage where the full channel separation is reached (VST) the LEVEL gain  $L_G$  has to be defined. The following equation can be used to estimate the gain:

$$L_G = V_{REF1}/FSU@full\ stereo$$

The MONO-voltage VMO (0dB channel separation) can be chosen selecting VSBL.

**Figure 6. Relation between internal and external level-voltagees and setup of stereoblend**

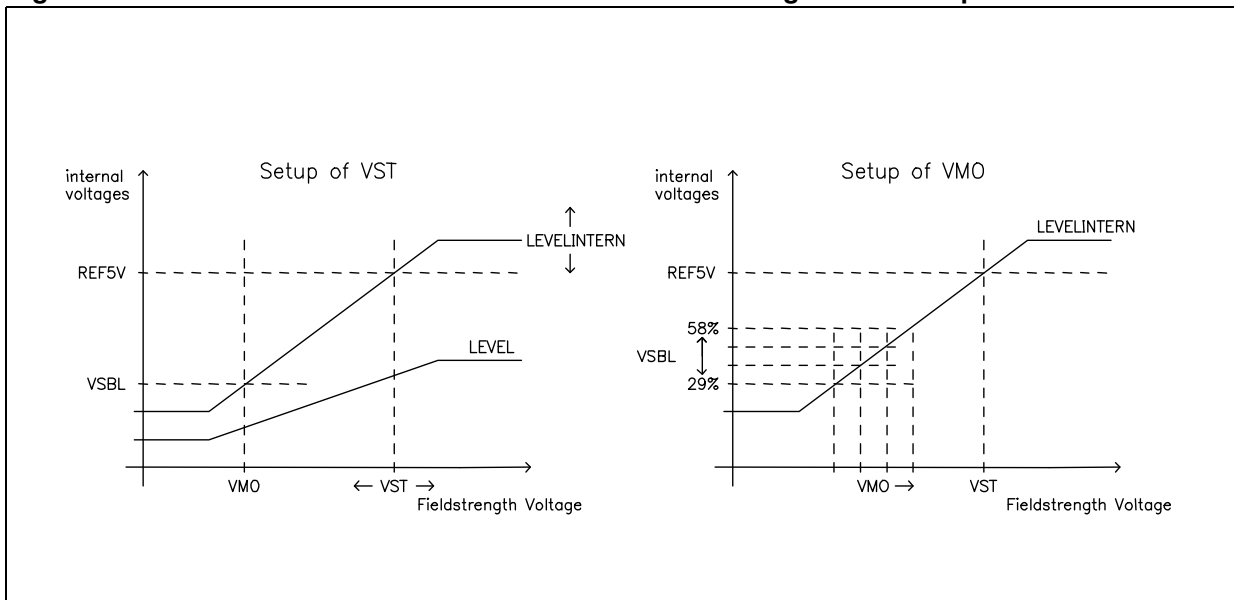

The stereo blend function can be switched ON/OFF using bit Addr25<d2>. Please note that in AM it must be switched in forced mono!

### Highcut control

The highcut control set-up is similar to the stereoblend control set-up: the starting point VHCH can be set with 2 bits to be 42, 50, 58 or 66% of  $V_{REF1}$  whereas the range can be set to be 11, 18.3, 25.7 or 33% of VHCH (see fig. 7).

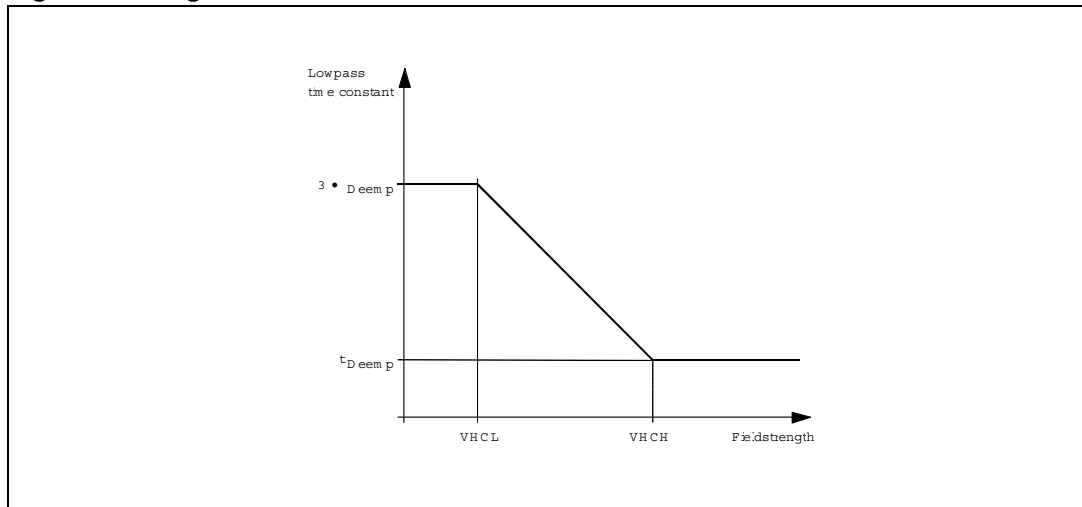
**Figure 7. Highcut characteristics**

### 4.3.2 Functional description of the noise blanker

In the automotive environment spikes produced by the ignition or for example the wiper-motor disturb the MPX-signal. The aim of the noise blanker part is to cancel the audible influence of the spikes. Therefore the output of the stereo decoder is held at the actual voltage for a time between  $22\mu s$  and  $38\mu s$  (programmable). The block diagram of the noise blanker is given in fig.15.

In a first stage the spikes must be detected but to avoid a wrong triggering on high frequency (white) noise a complex trigger control is implemented. Behind the trigger stage a pulse former generates the "blanking"-pulse. An own biasing circuit supplies the noise blanker in order to avoid any cross talk to the signal path.

#### Trigger path

The incoming MPX signal is high pass filtered, amplified and rectified. This second order high pass filter has a corner-frequency of 140kHz. The rectified signal, RECT, is low pass filtered to generate a signal called PEAK. Also noise with a frequency 140kHz increases the PEAK voltage. The resulting voltage can be adjusted by use of the noise rectifier discharge current. The PEAK voltage is fed to a threshold generator, which adds to the PEAK-voltage a DC-dependent threshold  $V_{TH}$ . Both signals, RECT and  $PEAK+V_{TH}$  are fed to a comparator, which triggers a re-triggerable monoflop. The monoflop's output activates the sample-and-hold circuits in the signal path for the selected duration.

#### Automatic noise controlled threshold adjustment (see [Figure 3](#))

There are mainly two independent possibilities for programming the trigger threshold:

1. the low threshold in 8 steps (NBLTH)
2. and the noise adjusted threshold in 4 steps (NBCTH).

The low threshold is active in combination with a good MPX signal without any noise; the PEAK voltage is less than 1V. The sensitivity in this operation is high.

If the MPX signal is noisy (low fieldstrength) the PEAK voltage increases due to the higher noise, which is also rectified. With increasing of the PEAK voltage the trigger threshold increases, too. This particular gain is programmable in 4 steps (NBCTH).

### Automatic threshold control by the stereoblend voltage (see [Figure 5](#))

Besides the noise controlled threshold adjustment there is an additional possibility for influencing the noise blanker trigger threshold using the bits NBFS. This influence depends on the stereoblend control.

The point where the MPX signal starts to become noisy is fixed by the RF part. This point is also the starting point of the normal noise-controlled trigger adjustment. But in some cases the noise blanker can create a wrong triggering, which create distortion, already in the region of mono/stereo transition. Therefore a opportunity to control the PEAK voltage by the stereo blend function it is implemented.

### Over deviation detector (see [Figure 4](#))

If the system is tuned to stations with a high deviation the noise blanker can trigger on the higher frequencies of the modulation. To avoid this wrong behavior, which causes noise in the output signal, the noise blanker offers a deviation-dependent threshold adjustment. By rectifying the MPX signal a further signal representing the actual deviation is obtained. It is used to increase the PEAK voltage. Offset and gain of this circuit are programmable in 3 steps (NBDTH) of the stereo decoder-byte (the first step turns off the detector).

### Multipath-level

To react on high repetitive spikes caused by a Multipath-situation, the discharge-time of the PEAK voltage can be decreased depending on the voltage-level at Pin MPout. There are two ways to do this. One way is to switch on the linear influence of the Multipath-Level on the PEAK-signal . In this case the discharge slew rate is  $1V/ms^{(a)}$ . The second possibility is to activate a function, which switches to the 18k discharge if the Multipath-Level is below 2.5V.

### AM mode of noise blanker

The TDA7540 offers an AM audio noise blanker too.

If the AM noise blanker is used the AM audio delay filter must be switched on. It is not recommended to use the AM noise blanker without to use the AMIF noiseblanker inside the tuner.

Together with the IF AM noise blanker, this audio noise blanking can work in two different modes.

Mode 1 uses the same threshold controls like in FM mode. The detector uses in AM mode the audio input for spike detection. A combination of programmable gain stage and low pass filtering forms an envelope detector wich drives the noise blanker input via 10/20KHz, 1st/2nd order high pass filter.

In mode 2 only a fixed noise blanker threshold is used.

In order to blank the whole spike in AM mode the hold time of the S&H circuit is much longer than in FM mode ( $640\mu s$  -  $1,2ms$ )

## 4.3.3 Functional description of the multipath-detector

Using the internal Multipath-Detector the audible effects of a multipath condition can be minimized. A multipath-condition is detected by rectifying the 19kHz spectrum in the fieldstrength signal. An external capacitor is used to define the attack- and decay-times (see

a. The slew rate is measured with  $R_{Discharge}=\infty$  and  $V_{MPout}=2.5V$

block diagram, fig. 16). The MP\_OUT-pin is used as detector-output connected to a capacitor of about 47nF. Using this configuration an external adaptation to the user's requirement is possible without affecting the "normal" fieldstrength input (LEVEL) for the stereo decoder.

To keep the old value of the Multipath Detector during an AF-jump, the MP-Hold switch can disconnect the external capacitor. This switch is controlled directly by the AFS-Pin.

Selecting MPION the channel separation is automatically reduced during a multipath condition according to the voltage appearing at the MP\_OUT-pin.

### Programming

To obtain a good multipath performance an adaptation is necessary. Therefore the gain of the first 19kHz-bandpass is programmable in two steps (MPG), the gain of the second 19kHz-bandpass is programmable in four steps (MPBPG) and the rectifier gain is programmable in four steps(MPRG). Please note that the frequency of the first multipath bandpass (MPF) must be set to 19kHz! The attack- and decay-times can be set by the external capacitor value and the multipath detector charge current MPCC.

#### 4.3.4 Quality detector

The TDA7540 offers a quality detector output, which gives a voltage representing the FM-reception conditions. To calculate this voltage the MPX-noise and the multipath-detector output are summed according to the following formula:

$$V_{Qual} = 0.8b (V_{Noise}-0.8 V)+ a (V_{REF1}-V_{Mpout}).$$

The noise-signal is the PEAK-signal without additional influences (see noise blanker description). The factor 'a' can be programmed from 0.6 to 1.05(QDC) and the factor b can be programmed from 6dB to 15dB ( QNG). The output is a low impedance output able to drive external circuitry as well as simply fed to an AD-converter for RDS applications.

#### 4.3.5 AFS control and stereo decoder mute

The TDA7540 is supplied with several functionality to support AF-checks using the stereo decoder. The additional pin (AFS) is implemented in order to speed up the stereo decoder AF-functions compared to IIC controlling.

The block diagram of AFS function is shown in [Figure 17](#).

In order to separate the different functions of the AFS pin, two different logic thresholds are implemented. Below the higher threshold voltage (2.4V) only the multipath-detector is switched into small time constant (internal logical signal MPfast).

Below the lower threshold voltage (0.8V) the full AFS function is activated. The MPXIN pin is switched into high impedance mode (internal signal AFSMute), which avoids any clicks during the jump condition. If the stereo decoder is not muted, it is possible at the same time to evaluate the noise- and multipath-content of the alternate frequency using the Quality detector output.

Furthermore the AFS pin does also freeze the condition of pilot locking and magnitude (internal signal PDhold). The Pdhld signal is defined by  $V_{th1}$  or  $V_{th2}$ , dependent on the PDH signal.

## 4.4 PLL and if counter section

### 4.4.1 PLL frequency synthesizer block

This part contains a frequency synthesizer and a loop filter for the radio tuning system. Only one VCO is required to build a complete PLL system for FM world tuning and AM upconversion (see [Figure 9](#)). For auto search stop operation an IF counter system is available.

The PLL counter works in a two stages configuration. The first stage is a swallow counter with a two modulus (32/33) precounter. The second stage is an 11-bit programmable counter.

The circuit receives the scaling factors for the programmable counters and the values of the reference frequencies via an I<sup>2</sup>C-Bus interface. The reference frequency is generated by an adjustable internal (XTAL) oscillator followed by the reference divider. The main reference and step-frequencies are free selectable (RC, PC).

Output signals of the phase detector are switching the programmable current sources. The loop filter integrates their currents to a DC voltage.

The values of the current sources are programmable by 6 bits also received via the I<sup>2</sup>C Bus (A, B, CURRH, LPF).

To minimize the noise induced by the digital part of the system, a special guard configuration is implemented.

The loop gain can be set for different conditions by setting the current values of the chargepump generator.

#### Frequency generation for phase comparison

The RF signals applies a two modulus counter (32/33) pre-scaler, which is controlled by a 5-bit A-divider. The 5-bit register (PC0 to PC4) controls this divider. In parallel the output of the prescaler connects to an 11-bit B-divider. The 11-bit PC register (PC5 to PC15) controls this divider

Dividing range behind VCO divider:

$$f_{VCOdiv} = [33 \times A + (B + 1 - A) \times 32] \times f_{REF}$$

$$f_{VCOdiv} = (32 \times B + A + 32) \times f_{REF}$$

Important: For correct operation:  $A \leq 32$ ;  $B \geq A$

#### Three state phase comparator

The phase comparator generates a phase error signal according to phase difference between  $f_{SYN}$  and  $f_{REF}$ . This phase error signal drives the charge pump current generator.

#### Charge pump current generator

This system generates signed pulses of current. The phase error signal decides the duration and polarity of those pulses. The current absolute values are programmable by A register for high current and B register for low current.



### Inlock detector

Switching the chargepump in low current mode can be done either via software or automatically by the inlock detector, by setting bit LDENA to "1".

After reaching a phase difference about lower than 40nsec the chargepump is forced in low current mode. A new PLL divider alternation by I<sup>2</sup>C-Bus will switch the chargepump in the high current mode.

### Low noise CMOS op-amp

An internal voltage divider at pin VREF2 connects the positive input of the low noise op-amp. The charge pump output connects the negative input. This internal amplifier in cooperation with external components can provide an active filter. The negative input is switchable to three input pins, to increase the flexibility in application. This feature allows two separate active filters for different applications.

While the high current mode is activated LPHC output is switched on.

## 4.4.2 IF counter block

The aim of IF counter is to measure the intermediate frequency of the tuner for AM and FM mode. The input signal for FM and AM upconversion is the same 10.7MHz IF level after limiter. AM 450KHz signal is coming from narrow filtered IF2 before demodulation. A switch controlled by IF counter mode (IFCM) is choosing the input signal for IF counter.

The grade of integration is adjustable by eight different measuring cycle times. The tolerance of the accepted count value is adjustable, to reach an optimum compromise for search speed and precision of the evaluation.

### The IF-counter mode

The IF counter works in 3 modes controlled by IFCM register.

### Sampling timer

A sampling timer generates the gate signal for the main counter. The basically sampling time are in FM mode 6.25kHz ( $t_{TIM}=160\mu s$ ) and in AM mode 1kHz ( $t_{TIM}=1ms$ ). This is followed by an asynchronous divider to generate several sampling times.

### Intermediate frequency main counter

This counter is a 11 - 21-bit synchronous autoreload down counter. Five bits (CF) are programmable to have the possibility for an adjust to the centre frequency of the IF-filter. The counter length is automatic adjusted to the chosen sampling time and the counter mode (FM, AM-UPC, AM).

At the start the counter will be loaded with a defined value which is an equivalent to the divider value ( $t_{Sample} \times f_{IF}$ ).

If a correct frequency is applied to the IF counter frequency input at the end of the sampling time the main counter is changing its state from 0h to 1FFFFFFh.

This is detected by a control logic and an external search stop output is changing from LOW to HIGH. The frequency range inside which a successful count result is adjustable by the EW bits.

$$t_{CNT} = (CF + 1696 + 1) / f_{IF} \quad \text{FM mode}$$

$$t_{CNT} = (CF + 10688 + 1) / f_{IF} \quad \text{AM up conversion mode}$$

$$t_{CNT} = (CF + 488 + 1) / f_{IF} \quad \text{AM mode}$$

Counter result succeeded:

$$t_{TIM} \geq t_{CNT} - t_{ERR}$$

$$t_{TIM} \leq t_{CNT} + t_{ERR}$$

Counter result failed:

$$t_{TIM} > t_{CNT} + t_{ERR}$$

$$t_{TIM} < t_{CNT} - t_{ERR}$$

$t_{TIM}$  = IF timer cycle time (sampling time)

$t_{CNT}$  = IF counter cycle time

$t_{ERR}$  = discrimination window (controlled by the EW registers)

The IF counter is only started by inlock information from the PLL part. It is enabled by software (IFENA).

### Adjustment of the measurement sequence time

The precision of the measurements is adjustable by controlling the discrimination window. This is adjustable by programming the control registers EW.

The measurement time per cycle is adjustable by setting the registers IFS.

### Adjust of the Frequency Value

The center frequency of the discrimination window is adjustable by the control registers CF.

## 4.5 I<sup>2</sup>C-Bus interface

The TDA7540 supports the I<sup>2</sup>C-Bus protocol. This protocol defines any device that sends data onto the bus as a transmitter, and the receiving device as the receiver. The device that controls the transfer is a master and device being controlled is the slave. The master will always initiate data transfer and provide the clock to transmit or receive operations.

### 4.5.1 Data transition

Data transition on the SDA line must only occur when the clock SCL is LOW. SDA transitions while SCL is HIGH will be interpreted as START or STOP condition.

### 4.5.2 Start condition

A start condition is defined by a HIGH to LOW transition of the SDA line while SCL is at a stable HIGH level. This "START" condition must precede any command and initiate a data transfer onto the bus. The device continuously monitors the SDA and SCL lines for a valid START and will not response to any command if this condition has not been met.

### 4.5.3 Stop condition

A STOP condition is defined by a LOW to HIGH transition of the SDA while the SCL line is at a stable HIGH level. This condition terminates the communication between the devices and forces the bus-interface of the device into the initial condition.

### 4.5.4 Acknowledge

Indicates a successful data transfer. The transmitter will release the bus after sending 8 bits of data. During the 9th clock cycle the receiver will pull the SDA line to LOW level to indicate it receive the eight bits of data.

### 4.5.5 Data transfer

During data transfer the device samples the SDA line on the leading edge of the SCL clock. Therefore, for proper device operation the SDA line must be stable during the SCL LOW to HIGH transition.

### 4.5.6 Device addressing

To start the communication between two devices, the bus master must initiate a start instruction sequence, followed by an eight bit word corresponding to the address of the device it is addressing.

The most significant 6 bits of the slave address are the device type identifier.

The TDA7540 device type is fixed as "110001".

The next significant bit is used to address a particular device of the previous defined type connected to the bus.

The state of the hardwired PIN 59 defines the state of this address bit. So up to two devices could be connected on the same bus. When PIN 59 is connected to VCC2 and a resistor at PIN 55 versus ground of about 5,6k Ohm the address bit "1" is selected. In this case the AM part doesn't work. Otherwise the address bit "0" is selected (FM and AM is working). Therefor a double FM tuner concept is possible.

The last bit of the start instruction defines the type of operation to be performed:

- When set to "1", a read operation is selected
- When set to "0", a write operation is selected

The TDA7540 connected to the bus will compare their own hardwired address with the slave address being transmitted, after detecting a START condition. After this comparison, the TDA7540 will generate an "acknowledge" on the SDA line and will do either a read or a write operation according to the state of R/W bit.

### 4.5.7 Write operation

Following a START condition the master sends a slave address word with the R/W bit set to "0". The device will generate an "acknowledge" after this first transmission and will wait for a second word (the word address field). This 8-bit address field provides an access to any of the 64 internal addresses.

Upon receipt of the word address the TDA7540 slave device will respond with an "acknowledge". At this time, all the following words transmitted to the TDA7540 will be considered as Data. The internal address will be automatically incremented up to hex40 in

page mode. Than again subadresse hex60 has to be transmitted for following registers above 32.

After each word receipt the TDA7540 will answer with an "acknowledge".

#### 4.5.8 Read operation

If the master sends a slave address word with the R/W bit set to "1", the TDA7540 will transit one 8-bit data word. This data word includes the following informations:

bit0 (ISS filter, 1 = ON, 0 = OFF)

bit1 (ISS filter bandwidth, 1 = 80kHz, 0 = 120kHz)

bit2 (STEREO, 1 = STEREO, 0 = MONO)

bit3 (1 = PLL is locked in , 0 = PLL is locked out).

bit4 (fieldstrength indicator, 1 = lower as softmute threshold, 0 = higher as softmute threshold)

bit5 (adjacent channel indicator, 1 = adjacent channel present, 0 = no adjacent channel)

bit6 (deviation indicator, 1 = strong overdeviation present, 0 = no strong overdeviation)

bit7 (deviation indicator, 1 = overdeviation present, 0 = no overdeviation)

## 5 Software specification

The interface protocol comprises:

- start condition (S)
- chip address byte
- subaddress byte
- sequence of data (N bytes + Acknowledge)
- stop condition (P)

The pagermode is only working up to byte 31. After byte 31 it is need to send again the chip address followed by the subaddress 32 and the databytes starting from 32 up to 39!

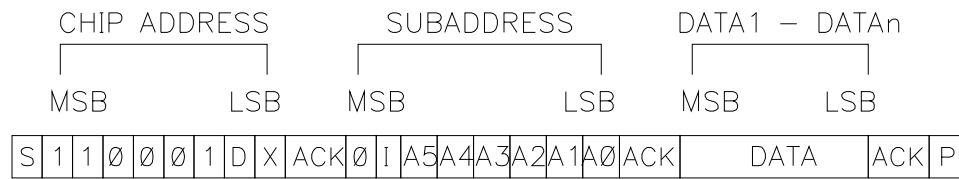

- S = Start
- P = Stop
- ACK = Acknowledge
- D = Device address
- X = R/W bit
- I = Pagemode
- A = Subaddress

### 5.1 Address organization

Table 9. Address organization

Function	Addr	7	6	5	4	3	2	1	0
CHARGE PUMP	0	FMSEEK	CURRH	B1	B0	A3	A2	A1	A0
PLL COUNTER	1	PC7	PC6	PC5	PC4	PC3	PC2	PC1	PC0
	2	PC15	PC14	PC13	PC12	PC11	PC10	PC9	PC8
TV1	3	TV1O7	TV1O6	TV1O5	TV1O4	TV1O3	TV1O2	TV1O1	TV1O0
TV2	4	TV2O7	TV2O6	TV2O5	TV2O4	TV2O3	TV2O2	TV2O1	TV2O0
IFC CTRL 1	5	LDENA	CASF	IFCM1	IFCM0	IFENA	IFS2	IFS1	IFS0
IFC CTRL 2	6	EW2	EW1	EW0	CF4	CF3	CF2	CF1	CF0
AM CTL	7	LM	TVMODE	TV2WB	TV1WB	AMD1	AMD0	AMST	AMSEEK
QUALITY ISS	8	TISS2	TISS1	TISS0	---	ISS30	ISS80	ISSON	CTLOFF
QUALITY AC	9	ACNTH1	ACNTH0	ACWTH2	ACWTH1	ACWTH0	ACG	ACF	---
QUALITY MP	10	MPAC	APPM2	APPM1	MPTH1	MPTH0	MPG	MPF	MPOFF
QUALITY DEV	11	BWCTL	DTH1	DTH0	DWTH1	DWTH0	TDEV2	TDEV1	TDEV0

**Table 9. Address organization (continued)**

Function	Addr	7	6	5	4	3	2	1	0
MUTE1	12	MENA	SMD3	SMD2	SMD1	SMD0	SMTH2	SMTH1	SMTH0
MUTE2	13	F100K	ACM3	ACM2	ACM1	ACM0	ACMD1	ACMD0	SMCTH
VCO/PLLREF	14	LPF	AMON	RC2	RC1	RC0	VCOD2	VCOD1	VCOD0
FMAGC	15	RFKAGC	KAGC2	KAGC1	KAGC0	IFAGC1	IFAGC0	RFAGC1	RFAGC0
AMAGC	16	DAGC3	DAGC2	DAGC1	DAGC0	WAGC3	WAGC2	WAGC1	WAGC0
DEM ADJ	17	DNB1	DNB0	DEM5	DEM4	DEM3	DEM2	DEM1	DEM0
LEVEL	18	ODSW	ODCUR	SMSL	SL4	SL3	SL2	SL1	SL0
IF1/XTAL	19	XTAL4	XTAL3	XTAL2	XTAL1	XTAL0	IFG11	IFG10	XTLIM
TANK ADJ	20	IF1T3	IF1T2	IF1T1	IF1T0	IF2T3	IF2T2	IF2T1	IF2T0
I/Q ADJ	21	SMO1	SMO0	---	---	PH3	PH2	PH1	PH0
AMIFNB	22	AINT1	AINT0	AINBD1	AINBD0	AINBT3	AINBT2	AINBT1	AINBT0
SCTRL	23	SSTH3	SSTH2	SSTH1	SSTH0	S2MODE	S2	S1MODE	S1
STD1	24	STVCO1	STVCO0	NBT1	NBT0	SI	TFCKL	NBFT	TSMA
STD2	25	STING1	STING0	DEEMP	PTH	NBPC	MS	STDON	STDM
STD3	26	NBDTH1	NBDTH0	NBON	NBCTH1	NBCTH0	NBLTH2	NBLTH1	NBLTH0
STD4	27	NBSMP	VHCL1	VHCL0	VHCH1	VHCH0	MAXHC1	MAXHC0	HCON
STD5	28	MPPC	QDC1	QDC0	NBFS1	NBFS0	SBC2	SBC1	SBC0
STD6	29	MPRG1	MPRG0	MPCC	MPION	MPBPG1	MPBPG0	NBRR1	NBRR0
STD7	30	AMAF	LG2	LG1	LG0	ROC3	ROC2	ROC1	ROC0
STD8	31	AMNBD	AMNBFO	AMNBHP	PDH	AFSM	AFSON	QNG1	QNG0
STD9	32	AMCF4	AMCF3	AMCF2	AMCF1	AMCF0	DESFT	---	---
TESTTU1	33	OUT20	ISSIN	TOUT	TIN1	CLKSEP	TEST3	TEST2	TEST1
TESTTU2	34	OUT7	OUT6	OUT5	OUT4	OUT3	OUT2	OUT1	OUT0
TESTTU3	35	---	TINACM	TINMP	TINAC	OUT11	OUT10	OUT9	OUT8
TESTTU4	36	OUT19	OUT18	OUT17	OUT16	OUT15	OUT14	OUT13	OUT12
TESTTU5	37	TIN2	OUT27	OUT26	OUT25	OUT24	OUT23	OUT22	OUT21
TESTSTD	38	---	---	MUXST3	MUXST2	MUXST1	MUXST0	---	TST
FMDEMSB	39	VCOM	PCM	---	SBSH	SBA	SBTO	SBW	SBT

## 5.2 Control register function

**Table 10. Control register function**

Register Name	Function
A	Charge pump high current
ACF	Adjacent channel filter select
ACG	Adjacent channel filter gain
ACM	Threshold for startpoint adjacent channel mute
ACMD	Adjacent channel mute depth
ACNTH	Adjacent channel narrow band threshold
ACWTH	Adjacent channel wide band threshold
AFSM	AFS influence on stereodecoder mute
AFSON	AFS Pin enable
AINBD	AM IF noise blanker desensitivity
AINBT	AM IF noise blanker threshold
AINT	AM IF noise blanking time
AMAF	AM audio filter
AMD	AM prescaler
AMCF	AM corner frequency
AMIN	AM IF1 input select
AMNBD	AM audio delay for noise blanking
AMNBFO	AM audio noise blanker high pass filter order
AMNBHP	AM audio noise blanker high pass filter frequency
AMON	AM-FM switch
AMSEEK	Set short time constant of AGC in AM seek mode
AMST	AM stereo select
APPM	Application mode quality detection
B	Charge pump low current
BWCTL	ISS filter fixed bandwidth (ISS80) in automatic control
CASF	Check alternative station frequency
CF	Center frequency IF counter
CLKSEP	Clock separation (only for testing)
CTLOFF	Switch off automatic control of ISS filter
CURRH	Set current high charge pump
DAGC	AM narrow band AGC threshold
DEEMP	Stereodecoder deemphasis
DEM	Demodulator offset

Table 10. Control register function (continued)

Register Name	Function
DESFT	Stereodecoder deemphasis shift
DNB	Demodulator spike blanking threshold
DTH	Deviation detector threshold for ISS filter "OFF"
DWTH	Deviation detector threshold for ISS filter narrow/wide
EW	Frequency error window IF counter
F100K	Corner frequency of AC-mute high pass filter
FMSEEK	ISS time constant change in FM seek mode
HCON	High cut enable
IF1T	FM/AM mixer1 tank adjust
IF2T	AM mixer2 tank adjust
IFAGC	FM IF AGC
IFCM	IF counter mode
IFENA	IF counter enable
IFG	IF1 amplifier gain (10.7MHz)
IFS	IF counter sampling time
ISSIN	Test input for ISS filter
ISSON	ISS filter "ON"
ISS30	ISS filter 30KHz weather band
ISS80	ISS filter narrow/mid switch
KAGC	FM keying AGC
LDENA	Lock detector enable
LG	Level gain adjust in stereodecoder
LM	Local mode FM seek stop
LPF	Loop filter input select
MAXHC	Maximum high cut
MENA	Softmute enable
MPAC	Adjacent channel control by multipath
MPCC	Multipath detector charge current
MPBPG	Multipath detector bandpass filter gain
MPF	Multipath filter frequency
MPG	Multipath filter gain
MPION	Multipath internal influence enable
MPOFF	Multipath control "OFF"
MPPC	Multipath influence on peak discharge current
MPRG	Multipath detector rectifier gain



Table 10. Control register function (continued)

Register Name	Function
MPTH	Multipath threshold
MS	Mono/Stereo switch automatically
MUXST	Test multiplexer output stereodecoder
NBCTH	Noise blanker noise controlled threshold
NBDTH	Noise blanker deviation controlled threshold
NBFS	Field strength controlled noise blanker
NBFT	AM noise blanker fixed threshold
NBLTH	Noise blanker low threshold
NBON	Noise blanker enable
NBPC	Noise blanker peak charge current
NBRR	Noise blanker rectifier discharge resistor
NBSMP	Strong multipath influence on noise blanker on/off
NBT	Noise blanker time
ODCUR	Current for overdeviation-correction
ODSW	Overdeviation-correction enable
OUT	Test output (only for testing)
PC	Counter for PLL (VCO frequency)
PCM	Pilot cancellation mode
PDH	PD hold activation
PH	I/Q mixer phase adjust
PTH	Pilot threshold
QDC	Quality detector coefficient
QNG	Quality noise gain
RC	Reference counter PLL
RFAGC	FM RF AGC
RFKAGC	FM RF keying AGC
ROC	Roll-Off compensation
S	Two mode switching output enable
SBA	FM demodulator spike blanker attack mode
SBC	Stereoblend control
SBSH	FM demodulator spike blanker sample&hold mode
SBT	FM demodulator spike blanker test mode
SBTO	FM demodulator spike blanker toggle mode
SBW	FM demodulator spike blanker window mode
SI	Signal invertion

Table 10. Control register function (continued)

Register Name	Function
SL	S meter slider
SMODE	Two mode switching output
SMCTH	Softmute capacitor threshold for ISS "ON"
SMD	Softmute depth threshold
SMO	Softmute reference voltage offset
SMSL	S meter slope
SMTH	Softmute startpoint threshold
SSTH	Unweighted fieldstrength threshold for seek stop
STDON	Stereodecoder on/off if muted
STDM	Stereodecoder mute enable
STING	Stereodecoder ingain
STVCO	Stereodecoder VCO adjust
TDEV	Time constant for deviation detector
TEST	Testing PLL/IFC (only for testing)
TFCKL	Fast clock for testing audioprocessor
TIN	Switch FSU PIN to TEST input (only for testing)
TINAC	Test input adjacent channel (only for testing)
TINACM	Test input adjacent channel mute (only for testing)
TINMP	Test input multipath(only for testing)
TISS	Time constant for ISS filter "ON"/"OFF"
TMSA	Test mode stereodecoder and audioprocessor
TOUT	Switch FSU PIN to Test output (only for testing)
TST	Test stereodecoder enable
TVMODE	Tuning voltage offset mode
TVO	Tuning voltage offset for prestage
TVWB	Tuning voltage offset for prestage (weather band mode)
VCOD	VCO divider
VCOM	Stereodecoder VCO mode
VHCH	Start level high cut
VHCL	Stop level high cut
WAGC	AM wide band AGC
XTAL	Xtal frequency adjust
XTLIM	Xtal amplitude limitation

Table 11. Subaddress

MSB							LSB	Function
	I	A5	A4	A3	A2	A1	A0	
		0	0	0	0	0	0	Charge pump control
		-	-	-	-	-	-	-
		1	0	0	0	0	0	STD9
		-	-	-	-	-	-	-
		1	0	0	1	1	1	FMDEMSB
	0							Page mode "OFF"
	1							Page mode enable

### 5.2.1 Data Byte Specification

Table 12. Addr 0 Charge Pump Control

MSB							LSB	Function
d7	d6	d5	d4	d3	d2	d1	d0	
				0	0	0	0	High current = 0mA
				0	0	0	1	High current = 0.5mA
				0	0	1	0	High current = 1mA
				0	0	1	1	High current = 1.5mA
				-	-	-	-	-
				1	1	1	1	High current = 7.5mA
		0	0					Low current = 0 $\mu$ A
		0	1					Low current = 50 $\mu$ A
		1	0					Low current = 100 $\mu$ A
		1	1					Low current = 150 $\mu$ A
	0							Select low current
	1							Select high current
	0							ISS time constant at PIN 27 available, FMSEEK "OFF"
	1							ISS time constant at PIN 28 available, FMSEEK "ON"

Table 13. Addr 1 PLL Counter 1 (LSB)

MSB							LSB	Function
d7	d6	d5	d4	d3	d2	d1	d0	
0	0	0	0	0	0	0	0	LSB = 0
0	0	0	0	0	0	0	1	LSB = 1
0	0	0	0	0	0	1	0	LSB = 2

**Table 13. Addr 1 PLL Counter 1 (LSB) (continued)**

MSB							LSB	Function
d7	d6	d5	d4	d3	d2	d1	d0	
-	-	-	-	-	-	-	-	-
1	1	1	1	1	1	0	0	LSB = 252
1	1	1	1	1	1	0	1	LSB = 253
1	1	1	1	1	1	1	0	LSB = 254
1	1	1	1	1	1	1	1	LSB = 255

**Table 14. Addr 2 PLL Counter 2 (MSB)**

MSB							LSB	Function
d7	d6	d5	d4	d3	d2	d1	d0	
0	0	0	0	0	0	0	0	MSB = 0
0	0	0	0	0	0	0	1	MSB = 256
0	0	0	0	0	0	1	0	MSB = 512
-	-	-	-	-	-	-	-	-
1	1	1	1	1	1	0	0	MSB = 64768
1	1	1	1	1	1	0	1	MSB = 65024
1	1	1	1	1	1	1	0	MSB = 65280
1	1	1	1	1	1	1	1	MSB = 65536

Swallow mode:  $f_{VCO}/f_{SYN} = LSB + MSB + 32$

**Table 15. Addr 3,4 TV1,2**

MSB							LSB	Function
d7	d6	d5	d4	d3	d2	d1	d0	
	0	0	0	0	0	0	0	Tuning Voltage Offset = 0
	0	0	0	0	0	0	1	TVO = 25mV
	0	0	0	0	0	1	0	TVO = 50mV
-	-	-	-	-	-	-	-	-
	1	1	1	1	1	1	1	TVO = 3175mV
0								-TVO
1								+TVO

Table 16. Addr 5 IF Counter Control 1

MSB								LSB		Function
d7	d6	d5	d4	d3	d2	d1	d0			
					0	0	0	$t_{\text{Sample}} = 20.48\text{ms (FM)128ms (AM)}$		
					0	0	1	$t_{\text{Sample}} = 10.24\text{ms (FM)64ms (AM)}$		
					0	1	0	$t_{\text{Sample}} = 5.12\text{ms (FM)32ms (AM)}$		
					0	1	1	$t_{\text{Sample}} = 2.56\text{ms (FM)16ms (AM)}$		
					1	0	0	$t_{\text{Sample}} = 1.28\text{ms (FM)8ms (AM)}$		
					1	0	1	$t_{\text{Sample}} = 640\mu\text{s (FM)4ms (AM)}$		
					1	1	0	$t_{\text{Sample}} = 320\mu\text{s (FM)2ms (AM)}$		
					1	1	1	$t_{\text{Sample}} = 160\mu\text{s (FM)1ms (AM)}$		
				0				IF counter disable / stand by		
				1				IF counter enable		
		0	0					Not valid		
		0	1					IF counter FM mode		
		1	0					IF counter AM mode (450KHz)		
		1	1					IF counter AM mode (10.7MHz)		
	0							Disable mute & AGC on hold in FM mode		
	1							Enable mute & AGC on hold in FM mode		
0								Lock detector disable		
1								Lock detector enable		

Table 17. Addr 6 IF Counter Control 2

MSB								LSB		Function
d7	d6	d5	d4	d3	d2	d1	d0			
			0	0	0	0	0	$f_{\text{Center}} = 10.60625\text{MHz (FM)} / 10.689\text{MHz} ; 449\text{KHz (AM)}$		
			0	0	0	0	1	$f_{\text{Center}} = 10.61250\text{MHz (FM)} / 10.690\text{MHz} ; 450\text{KHz (AM)}$		
-	-	-	-	-	-	-	-	-		
			0	1	0	1	1	$f_{\text{Center}} = 10.67500\text{MHz (FM)} / 10.700\text{MHz} ; 460\text{KHz (AM)}$		
			0	1	1	0	0	$f_{\text{Center}} = 10.68125\text{MHz (FM)} / 10.701\text{MHz} ; 461\text{KHz (AM)}$		
			0	1	1	0	1	$f_{\text{Center}} = 10.68750\text{MHz (FM)} / 10.702\text{MHz} ; 462\text{KHz (AM)}$		
			0	1	1	1	0	$f_{\text{Center}} = 10.69375\text{MHz (FM)} / 10.703\text{MHz} ; 463\text{KHz (AM)}$		
			0	1	1	1	1	$f_{\text{Center}} = 10.70000\text{MHz (FM)} / 10.704\text{MHz} ; 464\text{KHz (AM)}$		
-	-	-	-	-	-	-	-	-		
			1	1	1	1	1	$f_{\text{Center}} = 10.80000\text{MHz (FM)} / 10.720\text{MHz} ; 480\text{KHz (AM)}$		
0	0	0						Not valid		
0	0	1						Not valid		

**Table 17. Addr 6 IF Counter Control 2 (continued)**

MSB							LSB		Function
d7	d6	d5	d4	d3	d2	d1	d0		
0	1	0							Not valid
0	1	1							$\Delta f = 6.25\text{kHz}$ (FM) 1kHz (AM)
1	0	0							$\Delta f = 12.5\text{kHz}$ (FM) 2kHz (AM)
1	0	1							$\Delta f = 25\text{kHz}$ (FM) 4kHz (AM)
1	1	0							$\Delta f = 50\text{kHz}$ (FM) 8kHz (AM)
1	1	1							$\Delta f = 100\text{kHz}$ (FM) 16kHz (AM)

**Table 18. Addr 7 AM Control**

MSB							LSB		Function
d7	d6	d5	d4	d3	d2	d1	d0		
								0	Normal AGC time constant
								1	Short time constant for AM seek stop
								0	Multipath information available FM at PIN 24
								1	AM stereo output available at PIN 24
				0	0				Prescaler ratio 10
				0	1				Prescaler ratio 8
				1	0				Prescaler ratio 6
				1	1				Prescaler ratio 4
		0	0						Disable additional TV1, 2 offset
		0	1						Enable additional TV1 offset +3,175V (for weather band)
		1	0						Enable additional TV2 offset +3,175V (for weather band)
		1	1						Enable additional TV1, 2 offset +3,175V (for weather band)
	0								TV is tracking with PLL
	1								TV is independent on PLL
0									Disable local mode
1									Enable local mode (PIN diode current = 0.5mA)

**Table 19. Addr 8 Quality ISS Filter**

MSB							LSB		Function
d7	d6	d5	d4	d3	d2	d1	d0		
								0	ISS filter control "ON"
								1	ISS filter control "OFF"
								0	Switch ISS filter "OFF"
								1	Switch ISS filter "ON"

Table 19. Addr 8 Quality ISS Filter (continued)

MSB							LSB	Function
d7	d6	d5	d4	d3	d2	d1	d0	
					0			Switch "OFF" ISS filter 120kHz
					1			Switch "ON" ISS filter 80kHz
				0				Switch "OFF" ISS filter 30KHz for weatherband
				1				Switch "ON" ISS filter 30KHz for weatherband
0	0	0						discharge current1 $\mu$ A, charge current mid 74 $\mu$ A narrow124 $\mu$ A
0	0	1						discharge current3 $\mu$ A, charge current mid 72 $\mu$ A narrow122 $\mu$ A
0	1	0						discharge current5 $\mu$ A, charge current mid 70 $\mu$ A narrow120 $\mu$ A
0	1	1						discharge current7 $\mu$ A, charge current mid 68 $\mu$ A narrow118 $\mu$ A
-	-	-						-
1	1	1						discharge current15 $\mu$ A, charge current mid 60 $\mu$ A narrow110 $\mu$ A

Table 20. Addr 9 Quality Detection Adjacent Channel

MSB							LSB	Function
d7	d6	d5	d4	d3	d2	d1	d0	
							0/1	Not valid
							0	AC highpass frequency 100kHz
							1	AC bandpass frequency 100kHz
					0			AC gain 32dB
					1			AC gain 38dB
		0	0	0				AC wide band threshold 0.25V
		0	0	1				AC wide band threshold 0.35V
		0	1	0				AC wide band threshold 0.45V
		-	-	-				-
		1	1	1				AC wide band threshold 0.95V
0	0							AC narrow band threshold 0.0V
0	1							AC narrow band threshold 0.1V
1	0							AC narrow band threshold 0.2V
1	1							AC narrow band threshold 0.3V

**Table 21. Addr 10 Quality Detection Multipath**

MSB							LSB	Function
d7	d6	d5	d4	d3	d2	d1	d0	
							0	Multipath control "ON"
							1	Multipath control "OFF"
						0		MP bandpass frequency 19KHz
						1		MP bandpass frequency 31KHz
					0			MP gain 12dB
					1			MP gain 23dB
			0	0				MP threshold 0.50V
			0	1				MP threshold 0.75V
			1	0				MP threshold 1.00V
			1	1				MP threshold 1.25V
	0	0						Application mode 1
	0	1						Application mode 2
0								Multipath eliminates ac
1								Multipath eliminates ac and ac+

**Table 22. Addr 11 Quality Deviation Detection**

MSB							LSB	Function
d7	d6	d5	d4	d3	d2	d1	d0	
					0	0	0	charge current 39µA, discharge current 1µA
					0	0	1	charge current 37µA, discharge current 3µA
					0	1	0	charge current 35µA, discharge current 5µA
					0	1	1	charge current 33µA, discharge current 7µA
					-	-	-	-
					1	1	1	charge current 25µA, discharge current 15µA
			0	0				DEV threshold for ISS narrow/wide 30kHz
			0	1				DEV threshold for ISS narrow/wide 45kHz
			1	0				DEV threshold for ISS narrow/wide 60kHz
			1	1				DEV threshold for ISS narrow/wide 75kHz
	0	0						DEV threshold for ISS filter "OFF" ratio 1.5
	0	1						DEV threshold for ISS filter "OFF" ratio 1.4
	1	0						DEV threshold for ISS filter "OFF" ratio 1.3
	1	1						DEV threshold for ISS filter "OFF" ratio 1



Table 22. Addr 11 Quality Deviation Detection (continued)

MSB							LSB	Function
d7	d6	d5	d4	d3	d2	d1	d0	
0								Disable ISS filter to fixed bandwidth (ISS80) in automatic control
1								Enable ISS filter to fixed bandwidth (ISS80) in automatic control

Table 23. Addr 12 Softmute Control 1

MSB							LSB	Function
d7	d6	d5	d4	d3	d2	d1	d0	
					0	0	0	Startpoint mute 0 in application about 3dB $\mu$ V antenna level
					0	0	1	Startpoint mute 1 in application about 4dB $\mu$ V antenna level
					-	-	-	-
					1	1	1	Startpoint mute 7 in application about 10dB $\mu$ V antenna level
	0	0	0	0				Mute depth 0 in application 18dB
	0	0	0	1				Mute depth 1 in application 20dB
	0	0	1	0				Mute depth 2 in application 22dB
	0	0	1	1				Mute depth 3 in application 24dB
	-	-	-	-				- (logarithmically behaviour)
	1	1	1	1				Mute depth 15 in application 36dB
0								FM mute disable, (has to be 0 in AM mode)
1								FM mute enable

Table 24. Addr 13 Softmute Control 2

MSB							LSB	Function
d7	d6	d5	d4	d3	d2	d1	d0	
							0	Disable mute threshold for ISS filter "ON"
							1	Enable mute threshold for ISS filter "ON"
					0	0		AC mute depth 10dB
					0	1		AC mute depth 8dB
					1	0		AC mute depth 6dB
					1	1		AC mute depth 4dB
	0	0	0	0				AC mute threshold 60mV
	0	0	0	1				AC mute threshold 80mV
	0	0	1	0				AC mute threshold 100mV
	-	-	-	-				-
	0	1	1	1				AC mute threshold 340mV

**Table 24. Addr 13 Softmute Control 2 (continued)**

MSB							LSB		Function
d7	d6	d5	d4	d3	d2	d1	d0		
	1	1	1	1					AC mute "OFF"
0									AC mute filter 110KHz
1									AC mute filter 100KHz

**Table 25. Addr 14 VCODIV/PLLREF**

MSB							LSB		Function
d7	d6	d5	d4	d3	d2	d1	d0		
						0	0		not valid (only for testing)
						0	1		VCO frequency divided by 2
						1	0		VCO frequency divided by 3
						1	1		original VCO frequency
					0				VCO "I" signal 0 degree
					1				VCO "I" signal 180 degree
		1	0	0					PLL reference frequency 50KHz
		1	0	1					PLL reference frequency 25KHz
		1	1	0					PLL reference frequency 10KHz
		1	1	1					PLL reference frequency 9KHz
		0	0	0					PLL reference frequency 2KHz
	0								Select FM mode
	1								Select AM mode
0									Select PLL low pass filter FM
1									Select PLL low pass filter AM

**Table 26. Addr 15 FM AGC**

MSB							LSB		Function
d7	d6	d5	d4	d3	d2	d1	d0		
						0	0		RFAGC threshold $V_{9-11TH} = 85(77 \text{ ANT})dB\mu V$
						0	1		RFAGC threshold $V_{9-11TH} = 90(82 \text{ ANT})dB\mu V$
						1	0		RFAGC threshold $V_{9-11TH} = 94(86 \text{ ANT})dB\mu V$
						1	1		RFAGC threshold $V_{9-11TH} = 96(88 \text{ ANT})dB\mu V$
				0	0				IFAGC threshold $V_{77TH} = 86(60 \text{ ANT})dB\mu V$
				0	1				IFAGC threshold $V_{77TH} = 92(66 \text{ ANT})dB\mu V$
				1	0				IFAGC threshold $V_{77TH} = 96(70 \text{ ANT})dB\mu V$
				1	1				IFAGC threshold $V_{77TH} = 98(72 \text{ ANT})dB\mu V$

Table 26. Addr 15 FM AGC (continued)

MSB							LSB		Function
d7	d6	d5	d4	d3	d2	d1	d0		
	0	0	0						KAGC threshold 80dB $\mu$ V
	0	0	1						KAGC threshold 82dB $\mu$ V
	0	1	0						KAGC threshold 84dB $\mu$ V
	0	1	1						KAGC threshold 86dB $\mu$ V
	1	0	0						KAGC threshold 88dB $\mu$ V
	1	0	1						KAGC threshold 90dB $\mu$ V
	1	1	0						KAGC threshold 92dB $\mu$ V
	1	1	1						Keying AGC "OFF"
0									RF KAGC"OFF"
1									RF KAGC"ON"

Table 27. Addr 16 AM AGC

MSB							LSB		Function
d7	d6	d5	d4	d3	d2	d1	d0		
				0	0	0	0		WAGC $V_{4TH}= 90(65 \text{ ANT})dB\mu$ $V_{71TH}= 90(60 \text{ ANT})dB\mu$
				0	0	0	1		WAGC $V_{4TH}= 94(69 \text{ ANT})dB\mu$ $V_{71TH}= 94(64 \text{ ANT})dB\mu$
				0	0	1	0		WAGC $V_{4TH}= 97(72 \text{ ANT})dB\mu$ $V_{71TH}= 96,5(66,5 \text{ ANT})dB\mu$
				0	0	1	1		WAGC $V_{4TH}= 98,5(73,5 \text{ ANT})dB\mu$ $V_{71TH}= 98,5(68,5 \text{ ANT})dB\mu$
				0	1	0	0		WAGC $V_{4TH}= 100(75 \text{ ANT})dB\mu$ $V_{71TH}= 100(70 \text{ ANT})dB\mu$
				0	1	0	1		WAGC $V_{4TH}= 101,5(76,5 \text{ ANT})dB\mu$ $V_{71TH}= 101(71 \text{ ANT})dB\mu$
				0	1	1	0		WAGC $V_{4TH}= 102,5(77,5 \text{ ANT})dB\mu$ $V_{71TH}= 102,5(72,5 \text{ ANT})dB\mu$
				0	1	1	1		WAGC $V_{4TH}= 103,5(78,5 \text{ ANT})dB\mu$ $V_{71TH}= 103,5(73,5 \text{ ANT})dB\mu$
				1	0	0	0		WAGC $V_{4TH}= 104,5(79,5 \text{ ANT})dB\mu$ $V_{71TH}= 104(74 \text{ ANT})dB\mu$
				1	0	0	1		WAGC $V_{4TH}= 105(80 \text{ ANT})dB\mu$ $V_{71TH}= 105(75 \text{ ANT})dB\mu$
				1	0	1	0		WAGC $V_{4TH}= 106(81 \text{ ANT})dB\mu$ $V_{71TH}= 105,5(75,5 \text{ ANT})dB\mu$
				1	0	1	1		WAGC $V_{4TH}= 106,5(81,5 \text{ ANT})dB\mu$ $V_{71TH}= 106,5(76,5 \text{ ANT})dB\mu$
				1	1	0	0		WAGC $V_{4TH}= 107(82 \text{ ANT})dB\mu$ $V_{71TH}= 107(77 \text{ ANT})dB\mu$
				1	1	0	1		WAGC $V_{4TH}= 108(83 \text{ ANT})dB\mu$ $V_{71TH}= 107,5(77,5 \text{ ANT})dB\mu$
				1	1	1	0		WAGC $V_{4TH}= 108,5(83,5 \text{ ANT})dB\mu$ $V_{71TH}= 108(78 \text{ ANT})dB\mu$
				1	1	1	1		WAGC $V_{4TH}= 109(84 \text{ ANT})dB\mu$ $V_{71TH}= 108,5(78,5 \text{ ANT})dB\mu$
0	0	0	0						DAGC $V_{71TH}= 74(44 \text{ ANTENNA})dB\mu$

**Table 27. Addr 16 AM AGC (continued)**

MSB							LSB		Function
d7	d6	d5	d4	d3	d2	d1	d0		
0	0	0	1						DAGC $V_{71TH}= 77(47 \text{ ANTENNA})dB_{\mu}$
0	0	1	0						DAGC $V_{71TH}= 79(49 \text{ ANTENNA})dB_{\mu}$
0	0	1	1						DAGC $V_{71TH}= 80,5(50,5 \text{ ANTENNA})dB_{\mu}$
0	1	0	0						DAGC $V_{71TH}= 82(52 \text{ ANTENNA})dB_{\mu}$
0	1	0	1						DAGC $V_{71TH}= 83,5(53,5 \text{ ANTENNA})dB_{\mu}$
0	1	1	0						DAGC $V_{71TH}= 85(55 \text{ ANTENNA})dB_{\mu}$
0	1	1	1						DAGC $V_{71TH}= 86,5(56,5 \text{ ANTENNA})dB_{\mu}$
1	0	0	0						DAGC $V_{71TH}= 88(58 \text{ ANTENNA})dB_{\mu}$
1	0	0	1						DAGC $V_{71TH}= 89(59 \text{ ANTENNA})dB_{\mu}$
1	0	1	0						DAGC $V_{71TH}= 90(60 \text{ ANTENNA})dB_{\mu}$
1	0	1	1						DAGC $V_{71TH}= 91(61 \text{ ANTENNA})dB_{\mu}$
1	1	0	0						DAGC $V_{71TH}= 92(62 \text{ ANTENNA})dB_{\mu}$
1	1	0	1						DAGC $V_{71TH}= 93(63 \text{ ANTENNA})dB_{\mu}$
1	1	1	0						DAGC $V_{71TH}= 94(64 \text{ ANTENNA})dB_{\mu}$
1	1	1	1						DAGC $V_{71TH}= 96(66 \text{ ANTENNA})dB_{\mu}$

**Table 28. Addr 17 FM Demodulator Fine Adjust**

MSB							LSB		Function
d7	d6	d5	d4	d3	d2	d1	d0		
		0	0	0	0	0	0	0	0mV
		0	0	0	0	0	0	1	+8.5mV
		0	0	0	0	0	1	0	+17mV
		-	-	-	-	-	-	-	-
		0	1	1	1	1	1	1	+263.5mV
		1	0	0	0	0	0	0	0mV
		1	0	0	0	0	0	1	-8.5mV
		1	0	0	0	0	1	0	-17mV
		-	-	-	-	-	-	-	-
		1	1	1	1	1	1	1	-263.5mV
0	0								Spike cancelation "OFF"
0	1								Threshold for spike cancelation 750mV
1	0								Threshold for spike cancelation 270mV
1	1								Threshold for spike cancelation 520mV

Table 29. Addr 18 S-Meter Slider

MSB							LSB		Function
d7	d6	d5	d4	d3	d2	d1	d0		
				0	0	0	0	0	S meter slider offset SL=0dB
				0	0	0	1	1	S meter offset SL=1dB
				0	0	1	0	0	S meter offset SL=2dB
				-	-	-	-	-	-
				1	1	1	1	1	S meter offset SL=15dB
			0						S meter offset -SL
			1						S meter offset +SL
		0							S Meter slope 1V/decade
		1							S meter slope 1.5V/decade
	0								Overdeviation correction current max=45μA
	1								Overdeviation correction current max=90μA
0									Overdeviation correction "OFF"
1									Overdeviation correction "ON"

Table 30. Addr 19 IF GAIN/XTAL Adjust

MSB							LSB		Function
d7	d6	d5	d4	d3	d2	d1	d0		
								0	Xtal amplitude limitation disable
								1	Xtal amplitude limitation enable
					0	0			IF1 gain1 9dB
					0	1			IF1 gain1 12dB
					1	0			IF1 gain1 15dB
					1	1			IF1 gain1 18dB
0	0	0	0	0					C <sub>Load</sub> 0pF
0	0	0	0	1					C <sub>Load</sub> 0.75pF
0	0	0	1	0					C <sub>Load</sub> 1.5pF
0	0	0	1	1					C <sub>Load</sub> 2.25pF
0	0	1	0	0					C <sub>Load</sub> 3pF
-	-	-	-	-					-
1	1	1	1	1					C <sub>Load</sub> 23.25pF

**Table 31. Addr 20 Tank Adjust**

MSB							LSB		Function
d7	d6	d5	d4	d3	d2	d1	d0		
				0	0	0	0	450kHz 0pF	
				0	0	0	1	450kHz 1.6pF	
				0	0	1	0	450kHz 3.2pF	
				0	0	1	1	450kHz 4.8pF	
				-	-	-	-	-	
				1	1	1	1	450kHz 24pF	
0	0	0	0					10.7MHz 0pF	
0	0	0	1					10.7MHz 0.55pF	
0	0	1	0					10.7MHz 1.1pF	
0	0	1	1					10.7MHz 1.65pF	
-	-	-	-					-	
1	1	1	1					10.7MHz 8.25pF	

**Table 32. Addr 21 I/Q FM Mixer1 Adjust**

MSB							LSB		Function
d7	d6	d5	d4	d3	d2	d1	d0		
				0	0	0	0	-7 degree	
				0	0	0	1	-6 degree	
				0	0	1	0	-5 degree	
				-	-	-	-	-	
				0	1	1	1	0 degree	
				1	0	0	0	+1 degree	
				1	0	0	1	+2 degree	
				-	-	-	-	-	
				1	1	1	1	+8degree	
0	0							Softmute reference offset OFF	
0	1							Softmute reference offset -50mV	
1	0							Softmute reference offset -100mV	
1	1							Softmute reference offset -150mV	

Table 33. Addr 22 AM IF Noise Blanker

MSB							LSB		Function
d7	d6	d5	d4	d3	d2	d1	d0		
				0	0	0	0	0	AINBT 0mV
				0	0	0	1	1	AINBT 12.5mV
				0	0	1	0	0	AINBT 25mV
				-	-	-	-	-	-
				1	1	1	1	1	AINBT 187.5mV
		0	0						AINBD "ON"
		0	1						AINBD 4.0V
		1	0						AINBD 3.2V
		1	1						AINBD "OFF"
0	0								AINBT 8 $\mu$ s
0	1								AINBT 11 $\mu$ s
1	0								AINBT 14 $\mu$ s
1	1								AINBT 17 $\mu$ s

Table 34. Addr 23 Switch Control

MSB							LSB		Function
d7	d6	d5	d4	d3	d2	d1	d0		
							0	0	S1 LOW output voltage
							1	1	S1 HIGH output voltage
						0			S1 emitter output available
						1			S1 open collector output available
					0				S2 LOW output voltage
					1				S2 HIGH output voltage
				0					S2 emitter output available
				1					S2 open collector output available
0	0	0	0						SSTOP=IFC (IF counter status)
0	0	0	1						SSTOP= H if IFC=H&FSU>0.89V
0	0	1	0						SSTOP= H if IFC=H&FSU>1.16V
0	0	1	1						SSTOP= H if IFC=H&FSU>1.43V
-	-	-	-						
1	1	1	1						SSTOP= H if IFC=H&FSU>4.67V

**Table 35. Addr 24 Stereodecoder 1**

MSB							LSB		Function
d7	d6	d5	d4	d3	d2	d1	d0		
								0	Test mode stereodecoder and audioprocessor "ON"
								1	Test mode stereodecoder and audioprocessor "OFF"
								0	Audio AM noise blanker fix threshold disable
								1	Audio AM noise blanker fix threshold enable
					0				Fast clock for testing audioprocessor "ON"
					1				Fast clock for testing audioprocessor "OFF"
				0					Audio inverter OFF
				1					Audio inverter ON
		0	0						Audio noise blanking time (FM = 38µs, AM = 1.2 ms)
		0	1						Audio noise blanking time (FM = 25,5µs, AM = 0.8 ms)
		1	0						Audio noise blanking time (FM = 32µs, AM = 1.0 ms)
		1	1						Audio noise blanking time (FM = 22µs, AM = 0.64 ms)
	0								Stereodecoder VCO adjust minus
	1								Stereodecoder no VCO adjust
0									Stereodecoder VCO adjust plus
1									Stereodecoder no VCO adjust

**Table 36. Addr 25 Stereodecoder 2**

MSB							LSB		Function
d7	d6	d5	d4	d3	d2	d1	d0		
								0	Stereo decoder mute disable
								1	Stereo decoder mute enable
								0	Stereo decoder "ON" if muted
								1	Stereo decoder "OFF" if muted
					0				Forced MONO, must be set in AM
					1				MONO/STEREO switch automatically
				0					Noise blanker peak charge current low
				1					Noise blanker peak charge current high
			0						Pilot threshold high
			1						Pilot threshold low
		0							Deemphasis 50µs
		1							Deemphasis 75µs
0	0								Stereodecoder ingain = 3,75dB
0	1								Stereodecoder ingain = 2,5dB



Table 36. Addr 25 Stereodecoder 2 (continued)

MSB								LSB	Function
d7	d6	d5	d4	d3	d2	d1	d0		
1	0								Stereodecoder ingain = 1,25dB
1	1								Stereodecoder ingain = 0dB

Table 37. Addr 26 Stereodecoder 3

MSB								LSB	Function
d7	d6	d5	d4	d3	d2	d1	d0		
					0	0	0		Audio noise blanker low threshold 280mV
					0	0	1		Audio noise blanker low threshold 261mV
					0	1	0		Audio noise blanker low threshold 242mV
					0	1	1		Audio noise blanker low threshold 223mV
					1	0	0		Audio noise blanker low threshold 204mV
					1	0	1		Audio noise blanker low threshold 185mV
					1	1	0		Audio noise blanker low threshold 166mV
					1	1	1		Audio noise blanker low threshold 147mV
			0	0					Audio noise blanker noise controlled threshold 1200mV
			0	1					Audio noise blanker noise controlled threshold 950mV
			1	0					Audio noise blanker noise controlled threshold 700mV
			1	1					Audio noise blanker noise controlled threshold 450mV
		0							Audio noise blanker OFF
		1							Audio noise blanker ON
0	0								Deviation adjust 2,0V
0	1								Deviation adjust 1,5V
1	0								Deviation adjust 1,0V
1	1								Deviation detector off

Table 38. Addr 27 Stereodecoder 4

MSB								LSB	Function
d7	d6	d5	d4	d3	d2	d1	d0		
								0	High Cut OFF
								1	High Cut ON
					0	0			max. High Cut 10dB
					0	1			max. High Cut 5.5dB
					1	0			max. High Cut 7.5dB
					1	1			max. High Cut 8.5dB

**Table 38. Addr 27 Stereodecoder 4 (continued)**

MSB							LSB		Function
d7	d6	d5	d4	d3	d2	d1	d0		
			0	0					Start level High Cut at 42% REF5V
			0	1					Start level High Cut at 50% REF5V
			1	0					Start level High Cut at 58% REF5V
			1	1					Start level High Cut at 66% REF5V
	0	0							Stop level High Cut at 11% VHCH
	0	1							Stop level High Cut at 18.3% VHCH
	1	0							Stop level High Cut at 25.7% VHCH
	1	1							Stop level High Cut at 33% VHCH
0									Strong multipath influence on peak discharge OFF
1									Strong multipath influence on peak discharge ON

**Table 39. Addr 28 Stereodecoder 5**

MSB							LSB		Function
d7	d6	d5	d4	d3	d2	d1	d0		
					0	0	0		Stereoblend control at 29% REF5V
					0	0	1		Stereoblend control at 33% REF5V
					0	1	0		Stereoblend control at 38% REF5V
					0	1	1		Stereoblend control at 42% REF5V
					1	0	0		Stereoblend control at 46% REF5V
					1	0	1		Stereoblend control at 50% REF5V
					1	1	0		Stereoblend control at 54% REF5V
					1	1	1		Stereoblend control at 58% REF5V
			0	0					Audio noise blanker field strength adjust 2,0V
			0	1					Audio noise blanker field strength adjust 1,6V
			1	0					Audio noise blanker field strength adjust 1,4V
			1	1					Audio noise blanker field strength adjust OFF
	0	0							Quality detector coefficient a=0,6
	0	1							Quality detector coefficient a=0,75
	1	0							Quality detector coefficient a=0,9
	1	1							Quality detector coefficient a=1,05
0									Multipath influence on peak discharge OFF
1									Multipath influence on peak discharge ON (-1V/ms)

Table 40. Addr 29 Stereodecoder 6

MSB							LSB		Function
d7	d6	d5	d4	d3	d2	d1	d0		
						0	0		Noise rectifier discharge resistor = infinite
						0	1		Noise rectifier discharge resistor =56K
						1	0		Noise rectifier discharge resistor =33K
						1	1		Noise rectifier discharge resistor =18K
				0	0				Multipath detector band pass gain =6dB
				0	1				Multipath detector band pass gain =12dB
				1	0				Multipath detector band pass gain =9dB
				1	1				Multipath detector band pass gain =10,5dB
			0						Multipath detector internal influence ON
			1						Multipath detector internal influence OFF
		0							Multipath detector charge current =0,8μA
		1							Multipath detector charge current =0,4μA
0	0								Multipath detector rectifier gain =7,6dB
0	1								Multipath detector rectifier gain =4,6dB
1	0								Multipath detector rectifier gain =0dB
1	1								Multipath detector rectifier gain disabled

Table 41. Addr 30 Stereodecoder 7

MSB							LSB		Function
d7	d6	d5	d4	d3	d2	d1	d0		
				0	0	0	0		Roll-Off compensation not allowed
				0	0	0	1		Roll-Off compensation 17.1%
				0	0	1	0		Roll-Off compensation 15.2%
				0	0	1	1		Roll-Off compensation 13.3%
				0	1	0	0		Roll-Off compensation 11.4%
				0	1	0	1		Roll-Off compensation 9.6%
				0	1	1	0		Roll-Off compensation 7.8%
				0	1	1	1		Roll-Off compensation 6.0%
				1	0	0	0		Roll-Off compensation not allowed
				1	0	0	1		Roll-Off compensation 4,7%
				1	0	1	0		Roll-Off compensation 2.9%
				1	0	1	1		Roll-Off compensation 1.3%
				1	1	0	0		Roll-Off compensation -0.2%
				1	1	0	1		Roll-Off compensation -1.8%

**Table 41. Addr 30 Stereodecoder 7 (continued)**

MSB							LSB	Function
d7	d6	d5	d4	d3	d2	d1	d0	
				1	1	1	0	Roll-Off compensation -3.4%
				1	1	1	1	Roll-Off compensation -5%
	0	0	0					Level gain 0dB
	0	0	1					Level gain 0.67dB
	0	1	0					Level gain 1.34dB
	-	-	-					-
	1	1	1					Level gain 4.7dB
0								AM audio filter "OFF"
1								AM audio filter "ON"

**Table 42. Addr 31 Stereodecoder 8**

MSB							LSB	Function
d7	d6	d5	d4	d3	d2	d1	d0	
							0 0	Quality noise gain =6dB
							0 1	Quality noise gain =9dB
							1 0	Quality noise gain =12dB
							1 1	Quality noise gain =15dB
					0			Enable AFS PIN
					1			Disable AFS PIN
				0				AFS influence on stereodecoder mute
				1				No AFS influence on stereodecoder mute
			0					PD hold activation if $AFS < V_{th1}$
			1					PD hold activation if $AFS < V_{th2}$
		0						AM audio noise blanker high pass filter frequency 10KHz
		1						AM audio noise blanker high pass filter frequency 20KHz
	0							AM audio noise blanker high pass filter order 1st
	1							AM audio noise blanker high pass filter order 2nd
0								AM audio delay for noise blanking "OFF"
1								AM audio delay for noise blanking "ON"

Table 43. Addr 32 Stereodecoder 9

MSB							LSB	Function
d7	d6	d5	d4	d3	d2	d1	d0	
					0			Deemphasis shift (25/37.5 $\mu$ s)
					1			Deemphasis no shift (50/75 $\mu$ s)
0	0	0	0	0				AM corner frequency = 3.18kHz
0	0	0	0	1				AM corner frequency = 3.10kHz
0	0	0	1	0				AM corner frequency = 3.02kHz
-	-	-	-	-				
1	1	1	0	1				AM corner frequency = 1.12kHz
1	1	1	1	1				AM corner frequency = 1.06kHz

Table 44. Addr 33 Test Tuner Control 1

MSB							LSB	Function
d7	d6	d5	d4	d3	d2	d1	d0	
0	0	0	0	0	0	0	0	Only for testing do not modify default setup.

Table 45. Addr 34 Test Tuner Control 2

MSB							LSB	Function
d7	d6	d5	d4	d3	d2	d1	d0	
0	0	0	0	0	0	0	0	Only for testing do not modify default setup.

Table 46. Addr 35 Test Tuner Control 3

MSB							LSB	Function
d7	d6	d5	d4	d3	d2	d1	d0	
0	0	0	0	0	0	0	0	Only for testing do not modify default setup.

Table 47. Addr 36 Test TUNER Control 4

MSB							LSB	Function
d7	d6	d5	d4	d3	d2	d1	d0	
0	0	0	0	0	0	0	0	Only for testing do not modify default setup.

Table 48. Addr 37 Test TUNER Control 5

MSB							LSB	Function
d7	d6	d5	d4	d3	d2	d1	d0	
0	0	0	0	0	0	0	0	Only for testing do not modify default setup.

**Table 49. Addr 38 Test Stereodecoder Control**

MSB							LSB	Function
d7	d6	d5	d4	d3	d2	d1	d0	
1	1	1	1	1	1	1	0	Only for testing do not modify default setup.

**Table 50. Addr39 FM Demodulator Spike Blanker And Stereo Decoder**

MSB							LSB	Function
d7	d6	d5	d4	d3	d2	d1	d0	
							0	Spike blanker testing "OFF"
							1	Spike blanker testing "ON"
						0		Spike blanker window mode: early + late
						1		Spike blanker window mode: early - late
					0			Spike blanker toggledetector disable
					1			Spike blanker toggledetector enable
				0				Spike blanker slow attack
				1				Spike blanker fast attack
			0					Spike blanker S&H mode: ignore restore
			1					Spike blanker S&H mode: standard
		1						Stereo decoder VCO ON (mandatory in FM mode)
		0						Stereo decoder VCO OFF
	0							Pilot cancellation mode: always
	1							Pilot cancellation mode: if pilot > threshold
0								Stereo decoder VCO set456
1								Stereo decoder VCO free running



Figure 10. Block diagram keying AGC

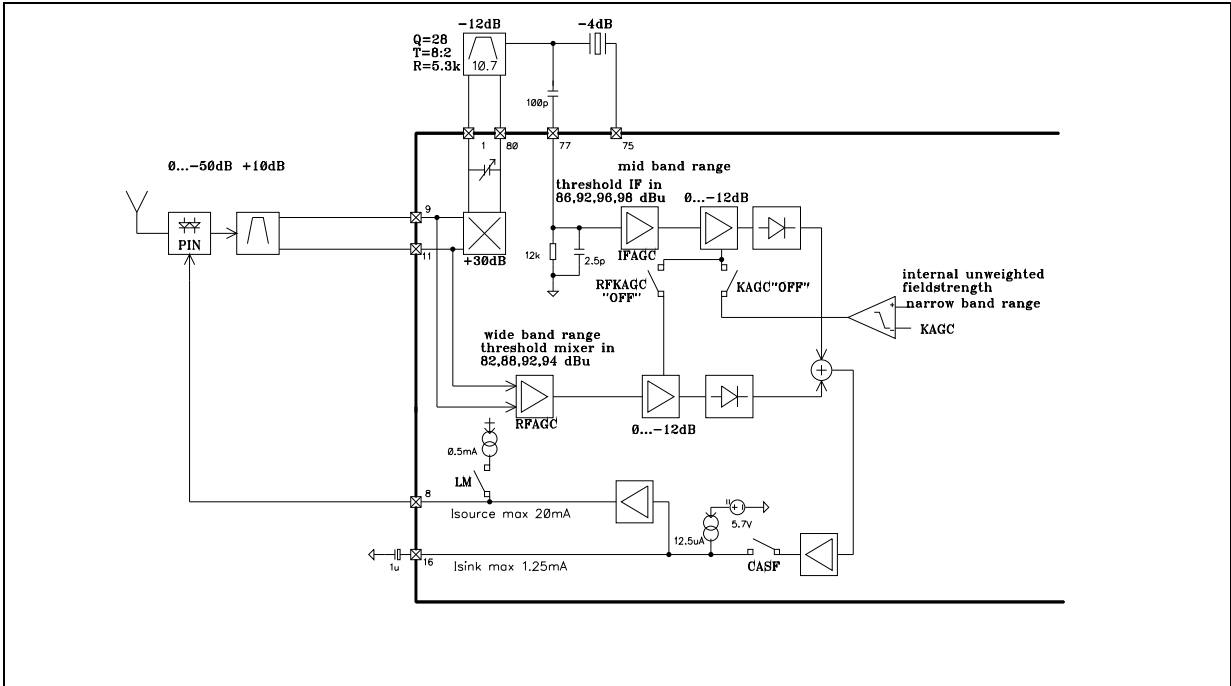
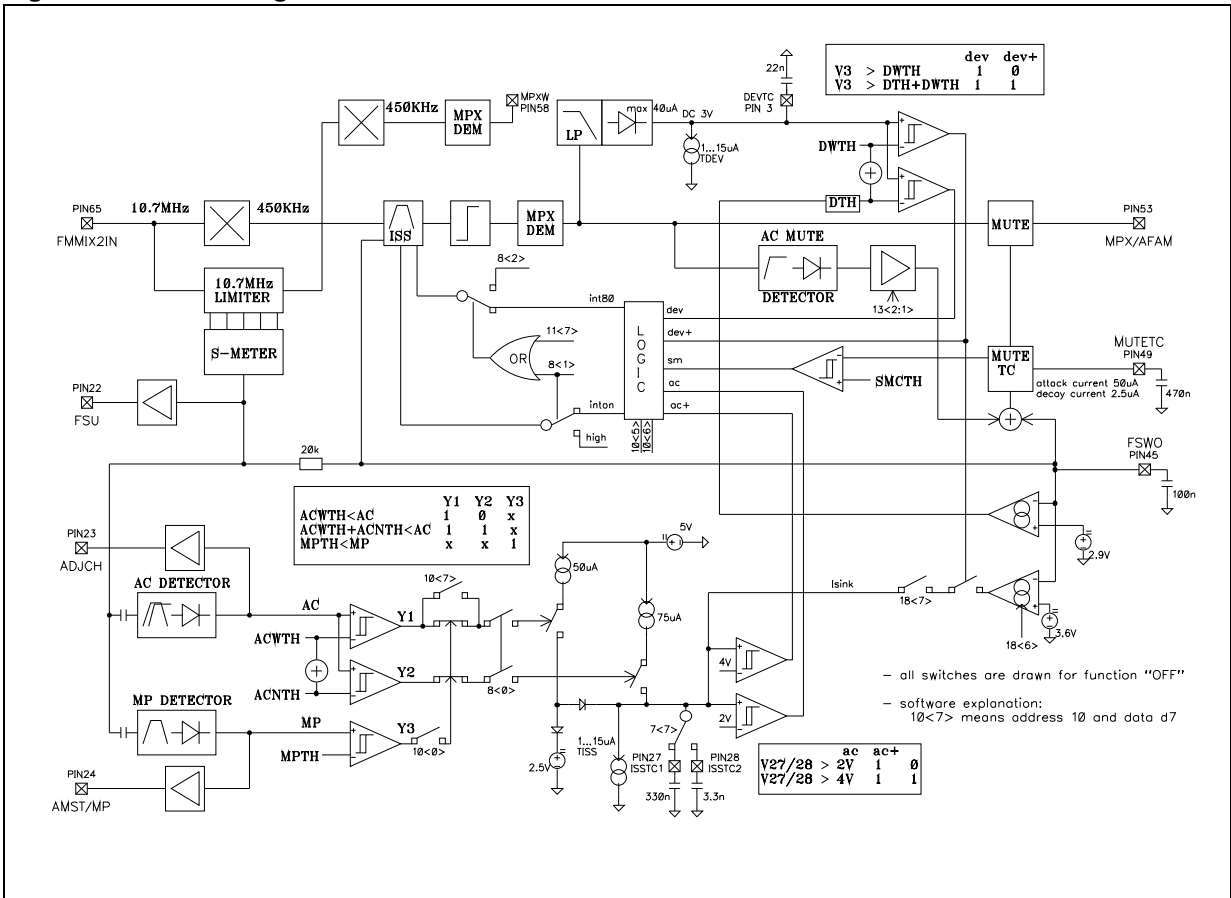

Figure 11. Block diagram ISS function





Block Diagram Quality Detection Principle (without overdeviation correction)

**Table 51.**

Signal	LOW	HIGH
ac	No adjacent channel	Adjacent channel present
ac+	No strong adjacent channel	Adjacent channel higher as ac
sm	Fieldstrength higher as softmute threshold	Fieldstrength lower as softmute threshold
dev	Deviation lower as threshold DWTH	Deviation higher as threshold DWTH
dev+	Deviation lower as threshold DTH*DWTH	Deviation higher as threshold DTH*DWTH
inton	ISS filter off by logic (wide)	ISS filter on by logic
int80	ISS filter 120kHz (mid)	ISS filter 80kHz (narrow)

**Table 52.**

Input Signals					Mode1			Mode2		
ac	ac+	sm	dev	dev+	inton	int80	Function	inton	int80	Function
0	0	0	0	0	0	0	wide	0	0	wide
0	0	0	1	0	0	0	wide	0	0	wide
0	0	0	1	1	0	0	wide	0	0	wide
0	0	1	0	0	1	1	narrow	1	1	narrow
0	0	1	1	0	0	0	wide	1	0	mid
0	0	1	1	1	0	0	wide	0	0	wide
1	0	0	0	0	1	1	narrow	1	0	mid
1	1	0	0	0	1	1	narrow	1	1	narrow
1	0	0	1	0	1	0	mid	1	0	mid
1	1	0	1	1	1	0	mid	1	1	narrow
1	0	1	0	0	1	1	narrow	1	1	narrow
1	1	1	0	0	1	1	narrow	1	1	narrow
1	0	1	1	0	1	0	mid	1	0	mid
1	1	1	1	0	1	0	mid	1	1	narrow
1	0	1	1	1	1	0	mid	1	0	mid
1	1	1	1	1	1	0	mid	1	1	narrow

Figure 12. Block diagram AM part

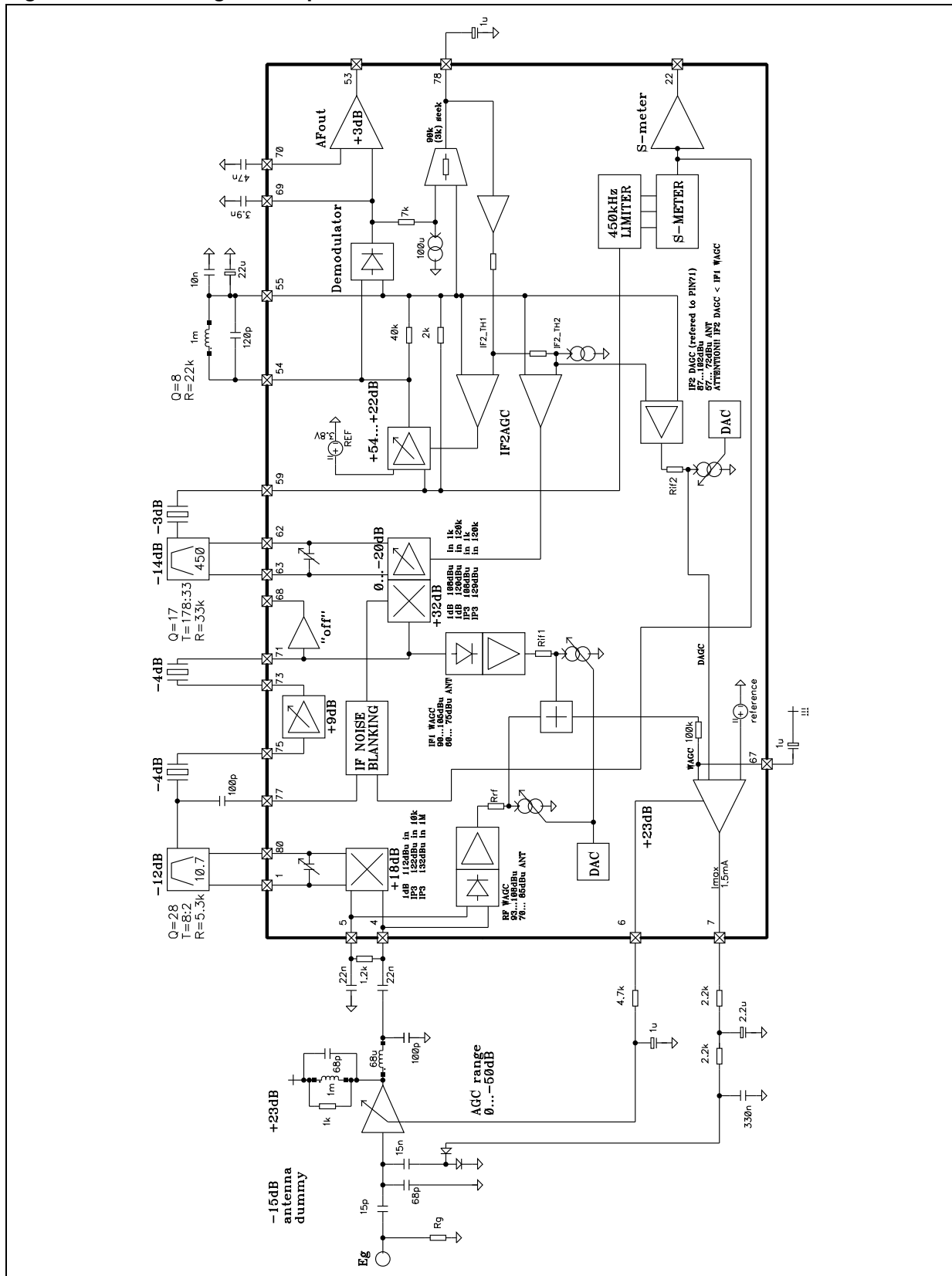

Figure 13. Blockdiagram AM IF Noise Blanker

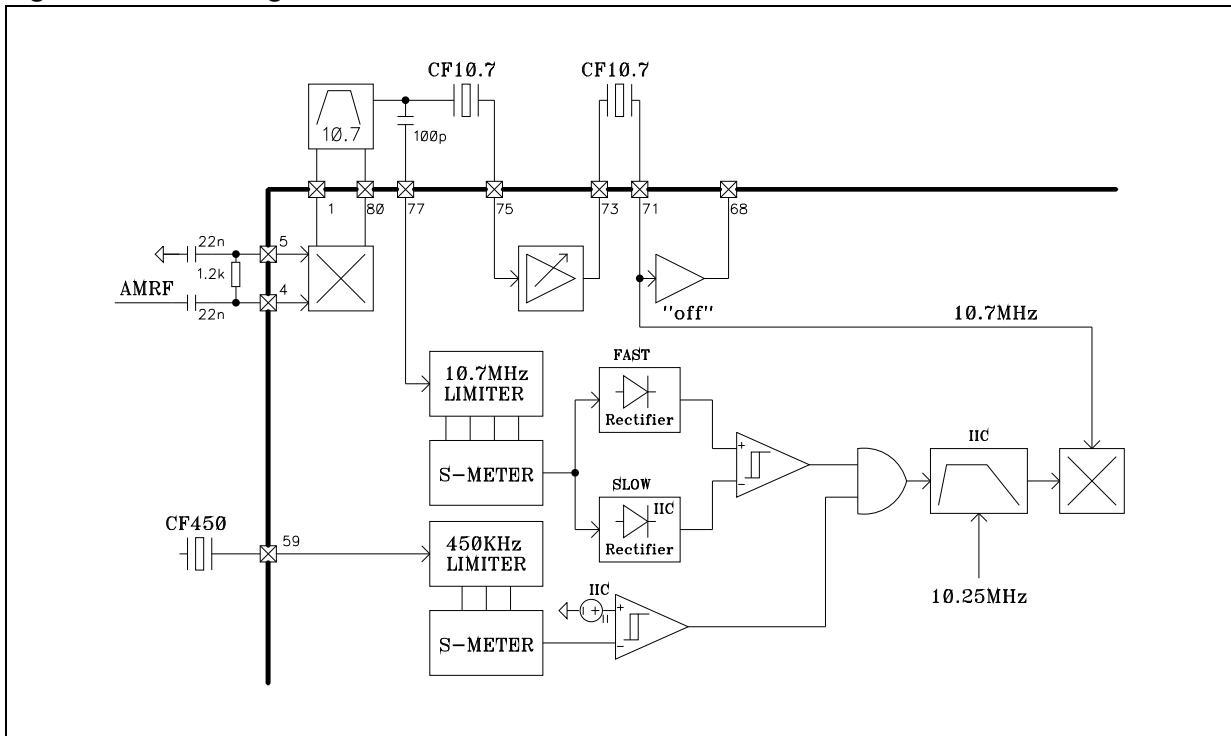

Figure 14. Block diagram Stereodecoder

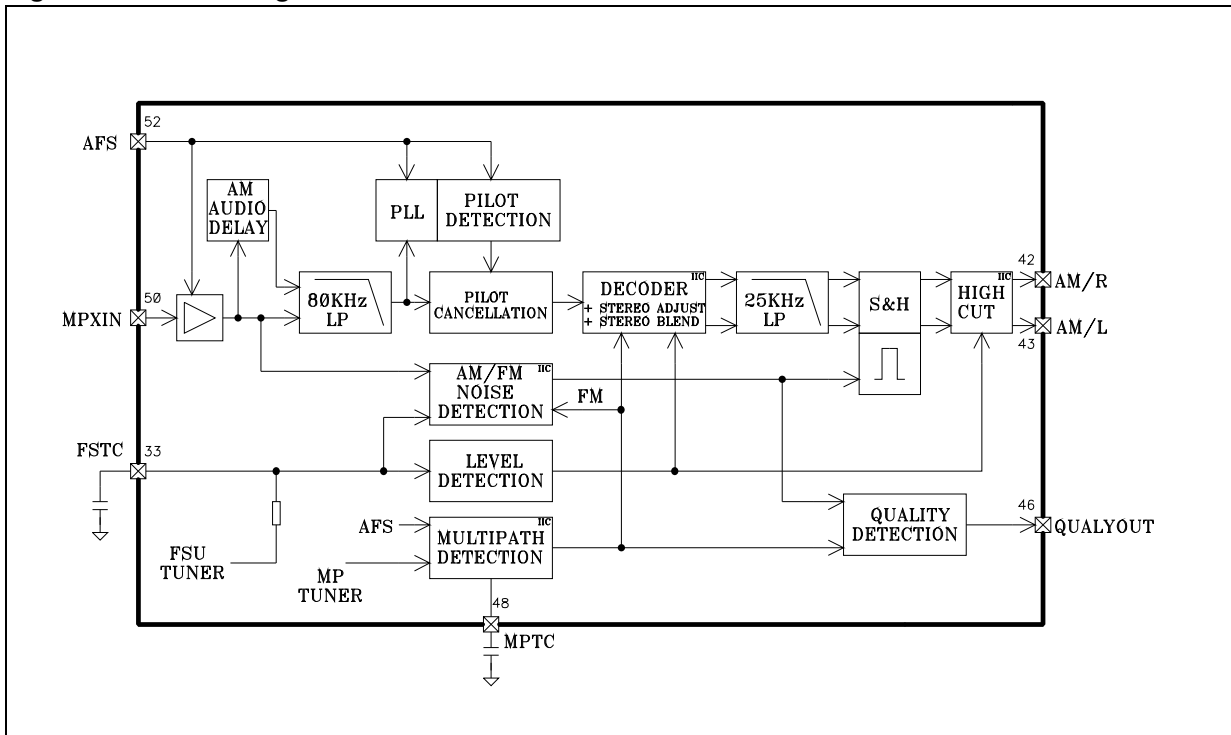

Figure 15. Block diagram Audio Noise Blanker

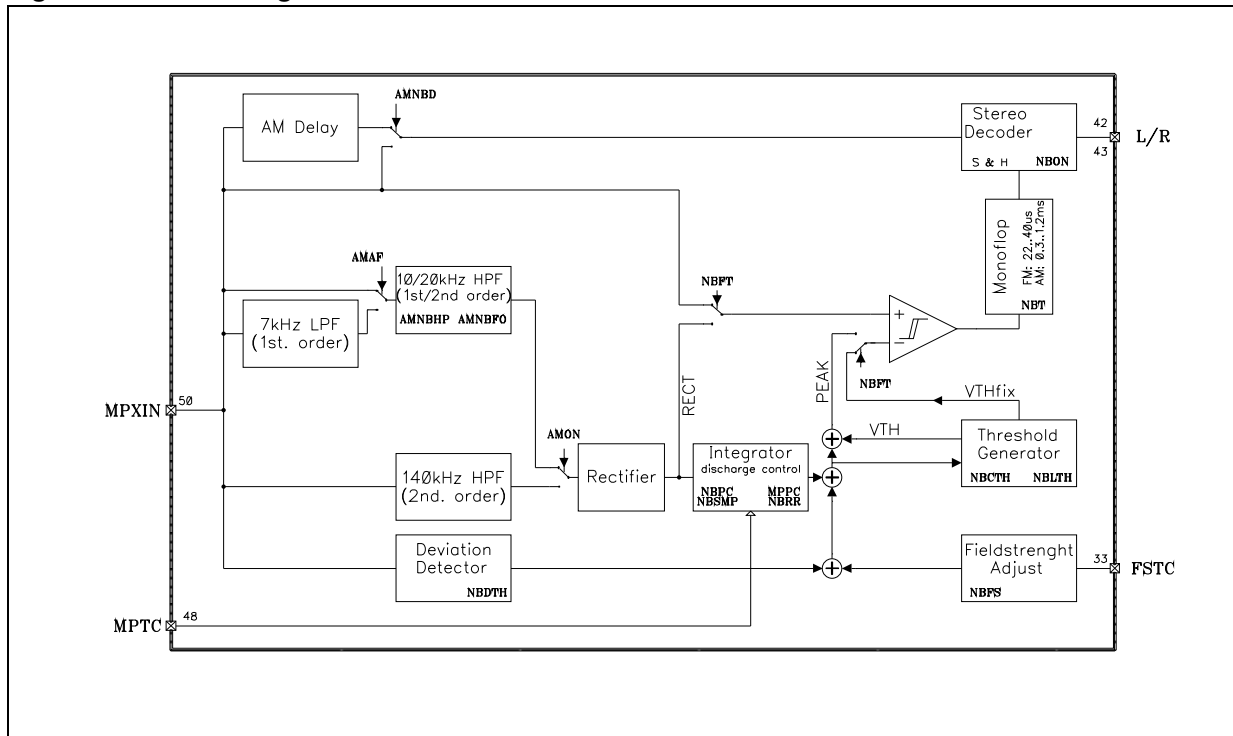

Figure 16. Block diagram Multipath Detection

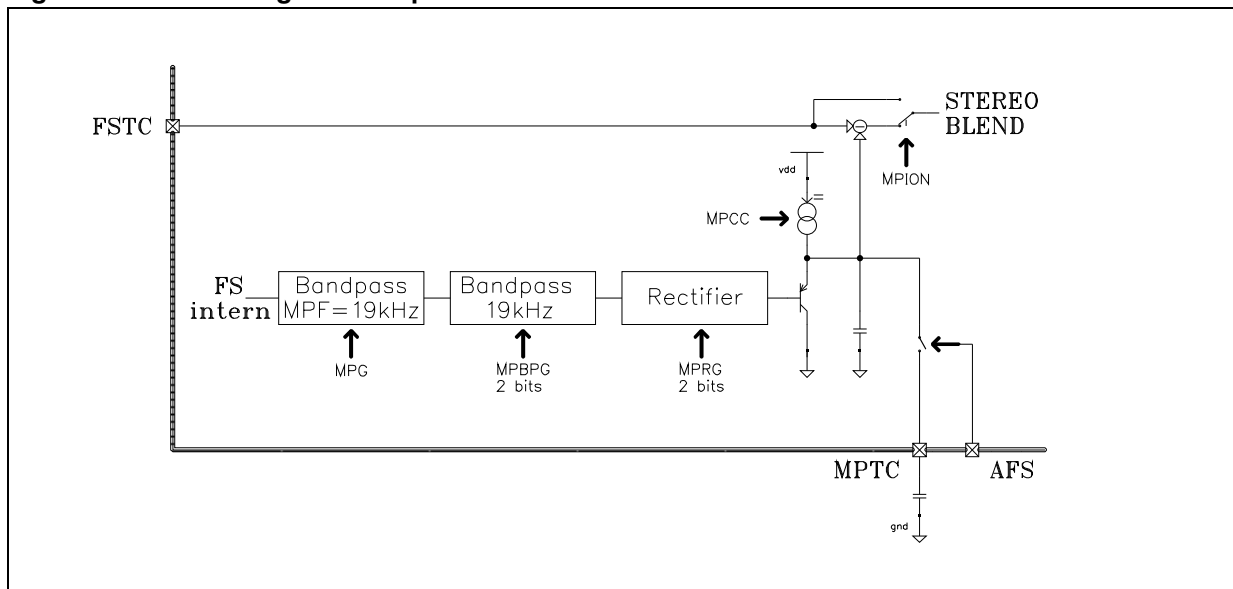
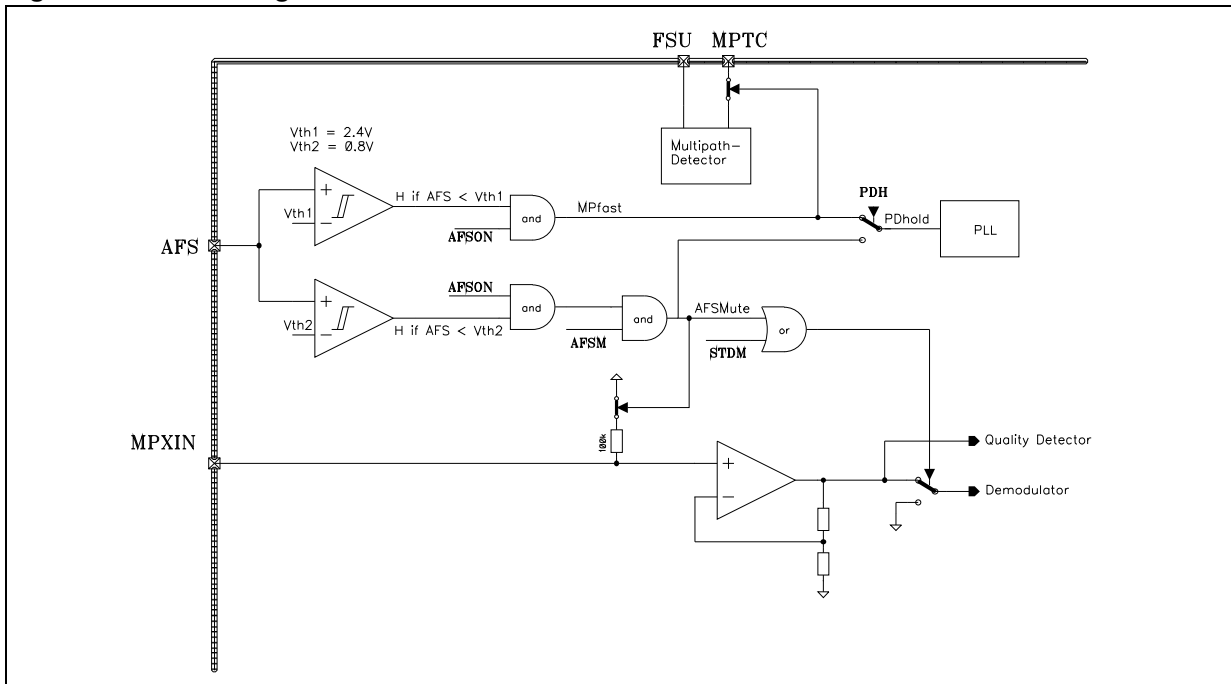

Figure 17. Block diagram AFS function



## 7 Part List (Application and measurement circuit)

Table 53. Part list

Item	Description
F1	TOKO 5KG 611SNS-A096GO
F2	TOKO 5KM 396INS-A467AO
F3	TOKO MC152 E558CN-100021=P3
F4	TOKO 7PSG P826RC-5134N
F5	TOKO PGL 5PGLC-5103N
L1	TOKO FSLM 2520-150 15 $\mu$ H
L2,L4	TOKO FSLM 2520-680 68 $\mu$ H
L3,L8	SIEMENS SIMID03 B82432 1mH
L5	TOKO LL 2012-220
L6	TOKO LL 2012-270
L7	TOKO LL 2012-22.0
CF1,CF2	muRata SFE10.7MS3A10-A 180KHz or (TOKO CFSK107M3-AE-20X)
CF3	muRata SFE10.7MJA10-A 150KHz or (TOKO CFSK107M4-AE-20X)
CF4	muRata SFPS 450H 6KHz or (TOKO ARLFC450T)
D1	TOSHIBA 1SV172
D2,D3	TOKO KP2311E
D4	TOKO KV1370NT
D5	PHILIPS BB156
Q1	TOSHIBA HN3G01J

# 8 Application circuit

Figure 18. Application circuit

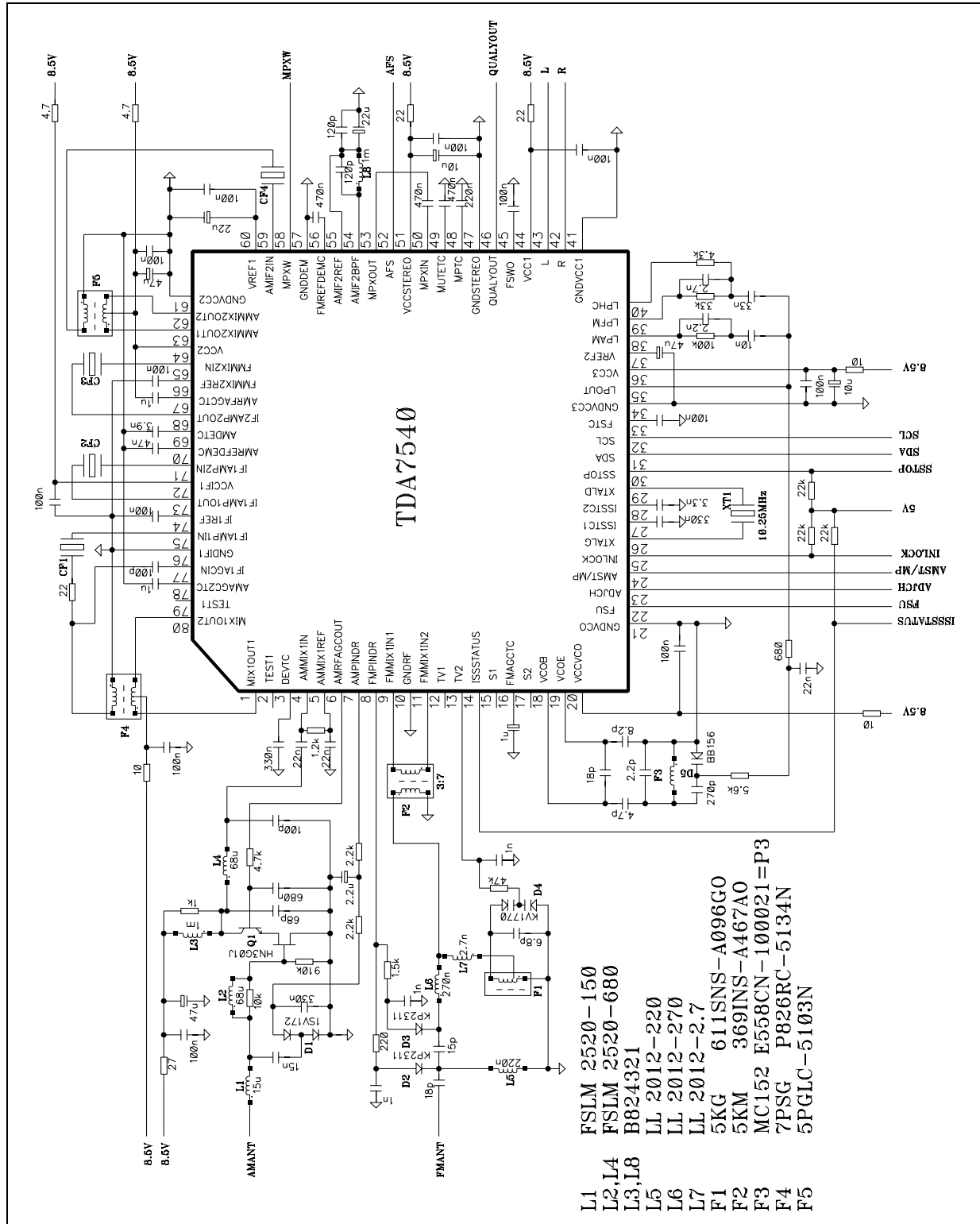

## 9 Application Notes

Following items are important to get highest performance of TDA7540 in application:

1. In order to avoid leakage current from PLL loop filter input to ground a guardring is recommended around loop filter PIN's with PLL reference (VREF2) voltage potential.
2. Distance between Xtal and VCO input PIN 18 should be far as possible and Xtal package should get a shield versus ground.
3. Blocking of VCO supply should be near at PIN 20 and PIN 21.
4. Blocking of VCC2 supply should be near at PIN 64 and PIN 61.
5. Wire lenght to FM mixer1-input and -output should be symetrically and short.
6. FM demodulator capacitance at PIN 56 should be sense connected as short as possible versus demodulator ground at PIN 57.
7. Wire lenght from AM mixer tank output to 9KHz ceramic filter input has to be short as possible.
8. To minimize "AM TWEET" the AM demodulator capacitor should be connected versus GNDVCC1 at PIN 41 and FSU output at PIN 22 should be filtered with capacitor of about 2,2nF versus GNDVCC2.



# 10 Package Information

In order to meet environmental requirements, ST offers these devices in ECOPACK® packages. These packages have a Lead-free second level interconnect. The category of second Level Interconnect is marked on the package and on the inner box label, in compliance with JEDEC Standard JESD97.

The maximum ratings related to soldering conditions are also marked on the inner box label.

ECOPACK is an ST trademark. ECOPACK specifications are available at: [www.st.com](http://www.st.com).

**Figure 19. TQFP80 (14x14x1.40mm) Mechanical Data & Package Dimensions**

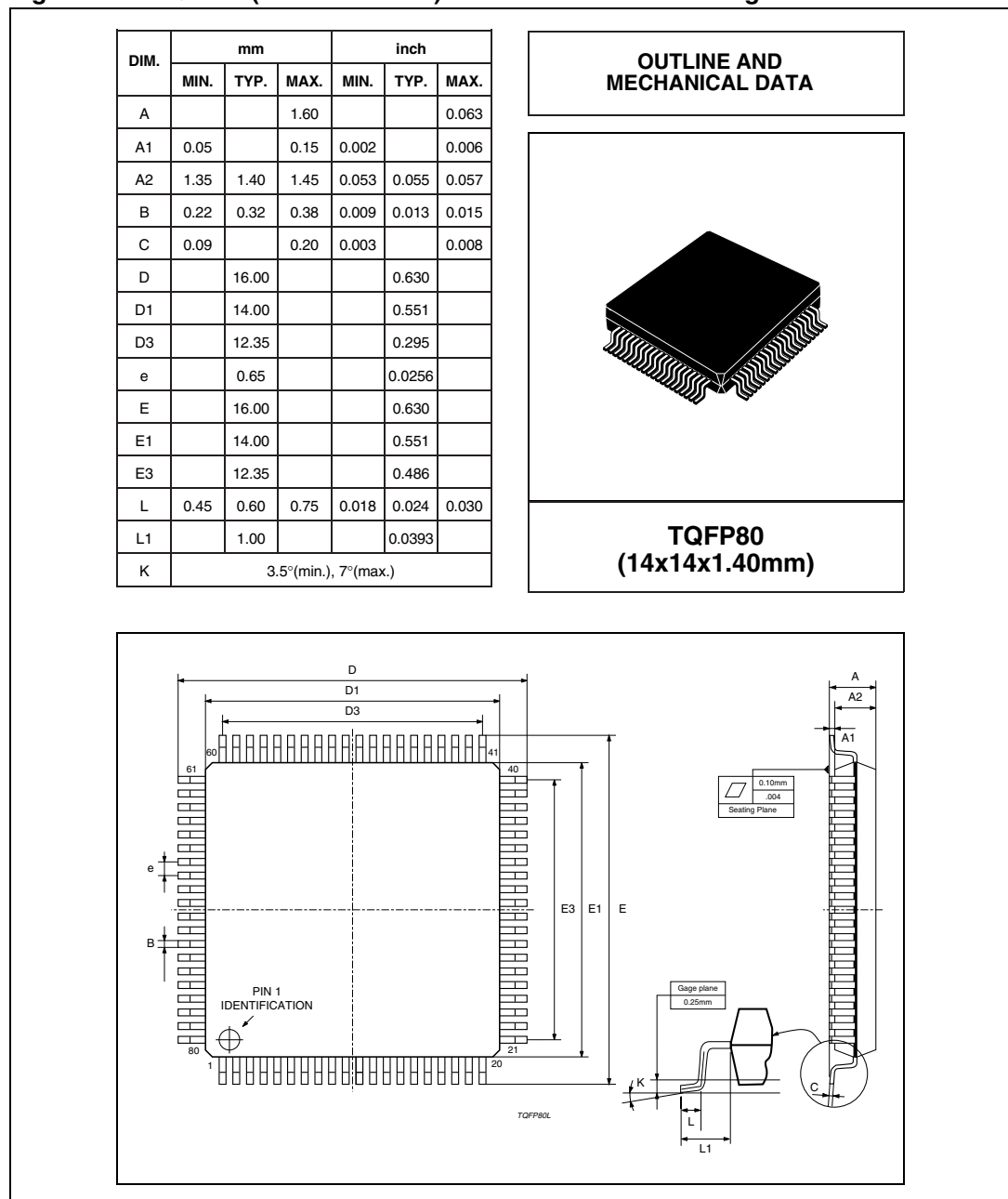

# 11 Revision history

**Table 54. Document revision history**

Date	Revision	Changes
10-May-2006	1	Initial release.
25-Sep-2013	2	Updated disclaimer.

**Please Read Carefully:**

Information in this document is provided solely in connection with ST products. STMicroelectronics NV and its subsidiaries ("ST") reserve the right to make changes, corrections, modifications or improvements, to this document, and the products and services described herein at any time, without notice.

All ST products are sold pursuant to ST's terms and conditions of sale.

Purchasers are solely responsible for the choice, selection and use of the ST products and services described herein, and ST assumes no liability whatsoever relating to the choice, selection or use of the ST products and services described herein.

No license, express or implied, by estoppel or otherwise, to any intellectual property rights is granted under this document. If any part of this document refers to any third party products or services it shall not be deemed a license grant by ST for the use of such third party products or services, or any intellectual property contained therein or considered as a warranty covering the use in any manner whatsoever of such third party products or services or any intellectual property contained therein.

**UNLESS OTHERWISE SET FORTH IN ST'S TERMS AND CONDITIONS OF SALE ST DISCLAIMS ANY EXPRESS OR IMPLIED WARRANTY WITH RESPECT TO THE USE AND/OR SALE OF ST PRODUCTS INCLUDING WITHOUT LIMITATION IMPLIED WARRANTIES OF MERCHANTABILITY, FITNESS FOR A PARTICULAR PURPOSE (AND THEIR EQUIVALENTS UNDER THE LAWS OF ANY JURISDICTION), OR INFRINGEMENT OF ANY PATENT, COPYRIGHT OR OTHER INTELLECTUAL PROPERTY RIGHT.**

**ST PRODUCTS ARE NOT DESIGNED OR AUTHORIZED FOR USE IN: (A) SAFETY CRITICAL APPLICATIONS SUCH AS LIFE SUPPORTING, ACTIVE IMPLANTED DEVICES OR SYSTEMS WITH PRODUCT FUNCTIONAL SAFETY REQUIREMENTS; (B) AERONAUTIC APPLICATIONS; (C) AUTOMOTIVE APPLICATIONS OR ENVIRONMENTS, AND/OR (D) AEROSPACE APPLICATIONS OR ENVIRONMENTS. WHERE ST PRODUCTS ARE NOT DESIGNED FOR SUCH USE, THE PURCHASER SHALL USE PRODUCTS AT PURCHASER'S SOLE RISK, EVEN IF ST HAS BEEN INFORMED IN WRITING OF SUCH USAGE, UNLESS A PRODUCT IS EXPRESSLY DESIGNATED BY ST AS BEING INTENDED FOR "AUTOMOTIVE, AUTOMOTIVE SAFETY OR MEDICAL" INDUSTRY DOMAINS ACCORDING TO ST PRODUCT DESIGN SPECIFICATIONS. PRODUCTS FORMALLY ESCC, QML OR JAN QUALIFIED ARE DEEMED SUITABLE FOR USE IN AEROSPACE BY THE CORRESPONDING GOVERNMENTAL AGENCY.**

Resale of ST products with provisions different from the statements and/or technical features set forth in this document shall immediately void any warranty granted by ST for the ST product or service described herein and shall not create or extend in any manner whatsoever, any liability of ST.

ST and the ST logo are trademarks or registered trademarks of ST in various countries.

Information in this document supersedes and replaces all information previously supplied.

The ST logo is a registered trademark of STMicroelectronics. All other names are the property of their respective owners.

© 2013 STMicroelectronics - All rights reserved

STMicroelectronics group of companies

Australia - Belgium - Brazil - Canada - China - Czech Republic - Finland - France - Germany - Hong Kong - India - Israel - Italy - Japan - Malaysia - Malta - Morocco - Philippines - Singapore - Spain - Sweden - Switzerland - United Kingdom - United States of America

[www.st.com](http://www.st.com)