

RTD2120-series

8051 Embedded Micro-Controller for Monitor

Fully Technology

Revision

Version 1.06

Last updated: 2007/4/3

Revision History

Rev.	Description	Date
1.02	<ol style="list-style-type: none"> 1. CLK02(XFR FF01[1]) default value 1 \rightarrow 0 2. PLL_TEST(XFR FF10[7]) \rightarrow PLL_STA 3. revise the “Reset table” 	2006/2/9
1.03	<ol style="list-style-type: none"> 1. revise the SFR table \rightarrow delete address 93 , B3 2. add PWM description 3. add power supply current 4. add description “All NC pin must be left unconnected or be connected to GND.” 	2006/8/1
1.04	<ol style="list-style-type: none"> 1. added RTD2120K, QFP44 pin config. 2. added RTD2120K, QFP44 pin description. 	2007/1/16
1.05	<ol style="list-style-type: none"> 1. added reset pulse minimum length is 16 MCU clk cycle (page-10) 	2007/2/9
1.06	<ol style="list-style-type: none"> 1. modified WDT block diagram 	2007/4/3

Overview

This chip is the micro-processor of LCD monitor. It uses the Designware DW8051 of Synopsys as the 8051 core of this chip and is compatible with other industry 8051 series. Also, 96Kbyte FLASH with 8 bit bus is embedded in this chip which is licensed from TSMC 0.18um e-FLASH process. Here we use the package of PLCC44/LQFP48/QFP44 if we would like to have a discrete MCU controller or we make a multi-chip package with our LCD monitor controller to form one chip package to save the cost of package and PCB material.

Features

- | Operating voltage range : 3.0V to 3.6V
- | 8051 core, CPU operating frequency up to 50MHz
- | 4 clocks per machine cycle
- | 256-byte internal RAM
- | 512-byte external data RAM, including 256-byte DDC RAM(128-byte x 2) and 256-byte general purpose RAM
- | 96K-byte flash memory, 64k for program and 32k for saving parameter
- | Two DDC ports compliant with VESA DDC1/2B/2Bi/CI
- | Three channels of PWM DAC with programmable frequency from 100K to 100Hz
- | Watchdog timer with programmable interval
- | Three 16-bit counters/timers (T0, T1, and T2)
- | One PLL to provide programmable operating frequency and clock output, 2 clock output ports
- | One full-duplex serial port
- | Six interrupt sources with 2 external interrupts
- | Four channels of 6-bit ADC
- | Hardware In System Programming(ISP) capability, no boot code required
- | Built-in Low voltage reset circuit
- | Embedded 1.8V regulator
- | Code protection
- | Available in 44-pin PLCC, 44-pin QFP or 48-pin LQFP package

Pin Configurations

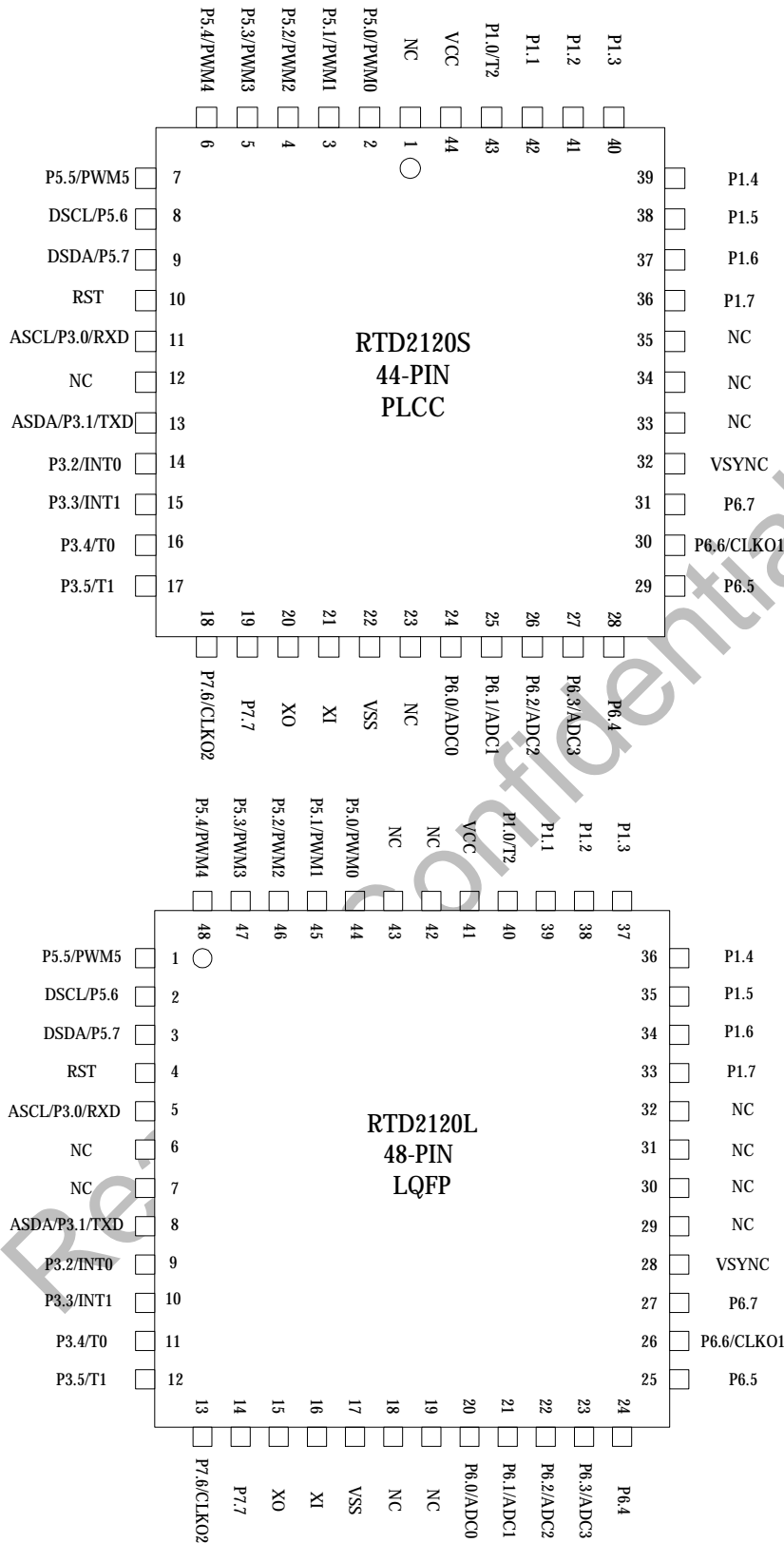

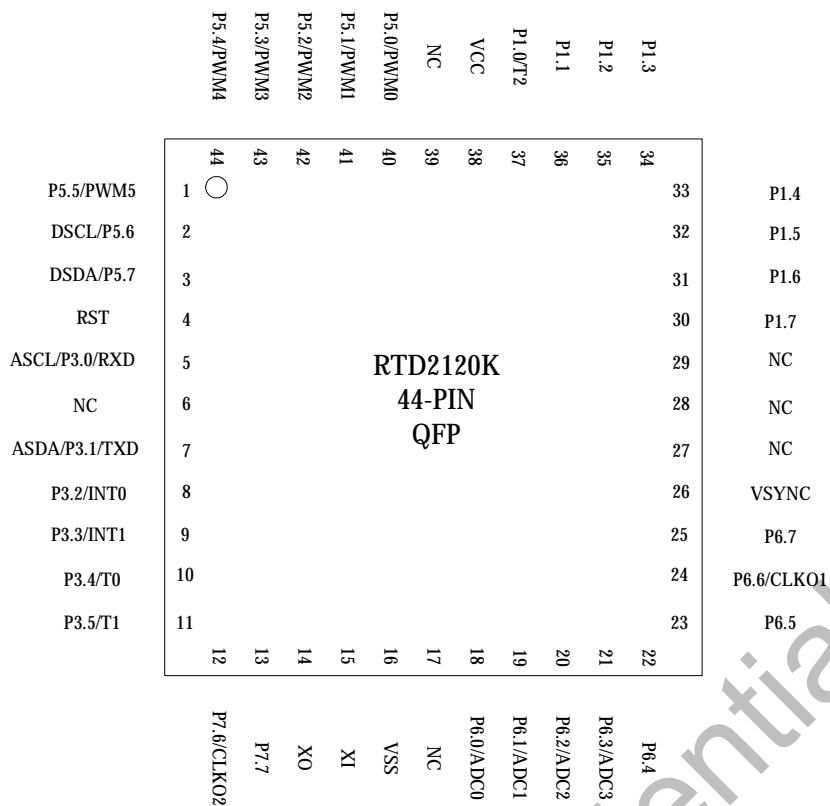

Block Diagram

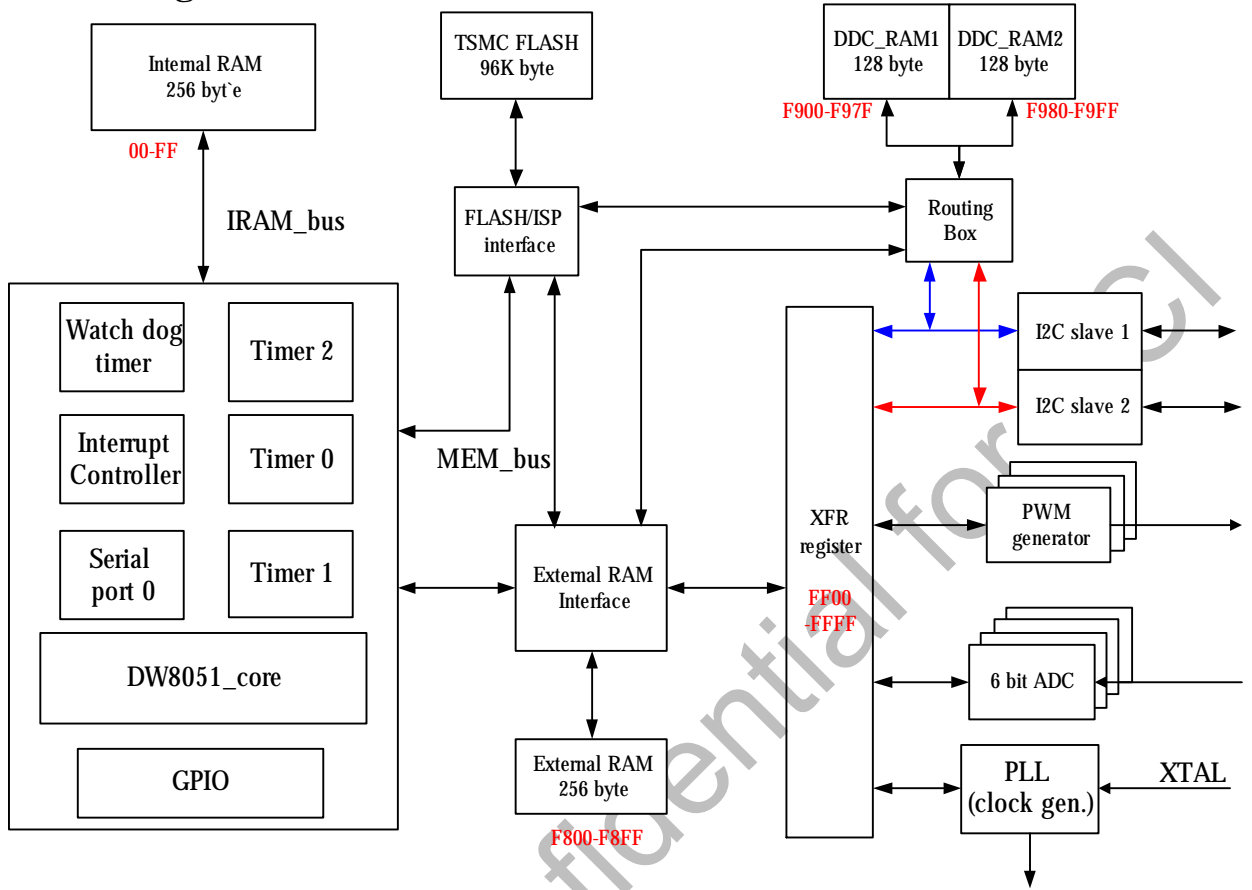

Pin Description

Pin No.			Name	I/O	Internal Pull Up/Down	Default output value	Pin Type	Description
PLCC 44	LQFP 48	QFP 44						
2	44	40	P5.0/PWM0	I/O	--	1(P5.0)	Open Drain	General purpose I/O / PWM0 output
3	45	41	P5.1/PWM1	I/O	--	1(P5.1)	Open Drain	General purpose I/O / PWM1 output
4	46	42	P5.2/PWM2	I/O	--	1(P5.2)	Open Drain	General purpose I/O / PWM2 output
5	47	43	P5.3/PWM3	I/O	--	1(P5.3)	Open Drain	General purpose I/O / PWM3 output
6	48	44	P5.4/PWM4	I/O	--	1(P5.4)	Open Drain	General purpose I/O / PWM4 output
7	1	1	P5.5/PWM5	I/O	--	1(P5.5)	Open Drain	General purpose I/O / PWM5 output
8	2	2	P5.6/DSCL	I/O	--	1(P5.6)	Open Drain	General purpose I/O / DVI DDC SCL
9	3	3	P5.7/DSDA	I/O	--	1(P5.7)	Open Drain	General purpose I/O / DVI DDC SDA
10	4	4	RST	I	Down	0	Input	High active RESET
11	5	5	ASCL/P3.0/RXD	I/O	--	1(ASCL)	Open Drain	ADC DDC SCL / General purpose I/O / RXD
13	8	7	ASDA/P3.1/TXD	I/O	--	1(ASDA)	Open Drain	ADC DDC SDA / General purpose I/O / TXD
14	9	8	P3.2/INT0	I/O	--	1(P3.2)	Standard 8051	General purpose I/O / External interrupt 0
15	10	9	P3.3/INT1	I/O	--	1(P3.3)	Standard 8051	General purpose I/O / External interrupt 1
16	11	10	P3.4/T0	I/O	--	1(P3.4)	Standard 8051	General purpose I/O / Timer 0
17	12	11	P3.5/T1	I/O	--	1(P3.5)	Standard 8051	General purpose I/O / Timer 1
18	13	12	P7.6/CLKO2	I/O	Up	1	Push-Pull	General purpose I/O / Clock out 2
19	14	13	P7.7	I/O	Up	1	Push-Pull	General purpose I/O
20	15	14	XO	O	--	--	--	Crystal out
21	16	15	XI	I	--	--	--	Crystal in
22	17	16	VSS	--	--	--	--	Ground

Pin No.			Name	I/O	Internal Pull Up/Down	Default output value	Pin Type	Description
PLCC	LQFP	QFP						
24	20	18	P6.0/ADC0	I/O	Up	1(P6.0)	Push-Pull	General purpose I/O / ADC 0 input
25	21	19	P6.1/ADC1	I/O	Up	1(P6.1)	Push-Pull	General purpose I/O / ADC 1 input
26	22	20	P6.2/ADC2	I/O	Up	1(P6.2)	Push-Pull	General purpose I/O / ADC 2 input
27	23	21	P6.3/ADC3	I/O	Up	1(P6.3)	Push-Pull	General purpose I/O / ADC 3 input
28	24	22	P6.4	I/O	Up	1	Push-Pull	General purpose I/O
29	25	23	P6.5	I/O	Up	1	Push-Pull	General purpose I/O
30	26	24	P6.6/CLKO1	I/O	Up	1(P6.6)	Push-Pull	General purpose I/O / Clock out 1
31	27	25	P6.7	I/O	Up	1	Push-Pull	General purpose I/O
32	28	26	VSYNC	I	Down	0	Input	VSYNC input
36	33	30	P1.7	I/O	--	1	Standard 8051/ Push-Pull	General purpose I/O
37	34	31	P1.6	I/O	--	1	Standard 8051/ Push-Pull	General purpose I/O
38	35	32	P1.5	I/O	--	1	Standard 8051/ Push-Pull	General purpose I/O
39	36	33	P1.4	I/O	--	1	Standard 8051/ Push-Pull	General purpose I/O
40	37	34	P1.3	I/O	--	1	Standard 8051/ Push-Pull	General purpose I/O
41	38	35	P1.2	I/O	--	1	Standard 8051/ Push-Pull	General purpose I/O
42	39	36	P1.1	I/O	--	1	Standard 8051/ Push-Pull	General purpose I/O
43	40	37	P1.0/ET2	I/O	--	1(P1.0)	Standard 8051/ Push-Pull	General purpose I/O / External Timer 2
44	41	38	VCC	--	--	--	--	Power

Note: All NC pin must be left unconnected or be connected to GND.

DW8051 micro-processor

The DW8051 contained in RTD2120 is compatible with industry standard 803x/805x and provides the following design features and enhancements to the standard 8051 microcontroller:

1. High speed architecture

Compared to standard 8051, the DW8051 processor core provides increased performance by executing instructions in a 4-clock bus cycle, as opposed to the 12-clock bus cycle in the standard 8051. The shortened bus timing improves the instruction execution rate for most instructions by a factor of three over the standard 8051 architectures. The average speed improvement for the entire instruction set is approximately 2.5X.

2. Stretch Memory Cycles

The stretch memory cycle feature enables application software to adjust the speed of data memory access. The DW8051 can execute the MOVX instruction in as little as 2 instruction cycles. However, it is sometimes desirable to stretch this value; for example, to access slow memory or slow memory-mapped peripherals such as UARTs or LCDs.

The three LSBs of the Clock Control Register (at SFR location 8Eh) control the stretch value. You can use stretch values between zero and seven. A stretch value of zero adds zero instruction cycles, resulting in MOVX instructions executing in two instruction cycles. A stretch value of seven adds seven instruction cycles, resulting in MOVX instructions executing in nine instruction cycles. The stretch value can be changed dynamically under program control.

By default, the stretch value resets to one (three cycle MOVX). For full-speed data memory access, the software must set the stretch value to zero. The stretch value affects only data memory access. The only way to reduce the speed of program memory (ROM) access is to use a slower clock.

3. Dual Data Pointers

The DW8051 employs dual data pointers to accelerate data memory block moves. The standard 8051 data pointer (DPTR) is a 16-bit value used to address external data RAM or peripherals. The DW8051 maintains the standard data pointer as DPTR0 at SFR locations 82h and 83h. It is not necessary to modify code to use DPTR0.

The DW8051 adds a second data pointer (DPTR1) at SFR locations 84h and 85h. The SEL bit in the DPTR Select register, DPS (SFR 86h), selects the active pointer. When SEL = 0, instructions that use the DPTR will use DPL0 and DPH0. When SEL = 1, instructions that use the DPTR will use DPL1 and DPH1. SEL is the bit 0 of SFR location 86h. No other bits of SFR location 86h are used.

All DPTR-related instructions use the currently selected data pointer. To switch the active pointer, toggle the SEL bit. The fastest way to do so is to use the increment instruction (INC DPS). This requires only one instruction to switch from a source address to a destination address, saving application code from having to save source and destination addresses when doing a block move.

Using dual data pointers provides significantly increased efficiency when moving large blocks of data.

4. Timer Rate Control

One important difference exists between the RTD2120 and 80C32 regarding timers. The original 80C32 used a 12 clock per cycle scheme for timers and consequently for some serial baud rates (depending on the mode). The RTD2120 architecture normally runs using 4 clocks per cycle. However, in the area of timers, it will default to a 12 clock per cycle scheme on a reset. This allows existing code with real-time dependencies such as baud rates to operate properly. If an application needs higher speed timers or serial baud rates, the timers can be set to run at the 4 clock rate.

The Clock Control register (CKCON – 8Eh) determines these timer speeds. When the relevant CKCON bit is a logic 1, the device uses 4 clocks per cycle to generate timer speeds. When the control bit is set to a zero, the device uses 12 clocks for timer speeds. The reset condition is a 0. CKCON.5 selects the speed of Timer 2. CKCON.4 selects Timer 1 and CKCON.3 selects Timer zero. Note that unless a user desires very fast timing, it is unnecessary to alter these bits. Note that the timer controls are independent.

Memory Organization

Internal Data memory

- | 256 bytes of internal RAM
- | 128 bytes of Special Function Register (SFR)

External Data memory

- | 128 bytes of External Special Function Register (XFR)
- | 256 bytes of DDCRAM(128-bytex2)
- | 256 bytes of general purpose RAM
- | 32k bytes of flash for EDID data and other parameters

External Program memory

- | 64k bytes of flash for program memory
- | The program content can not be read out unless user mass erase the flash first.

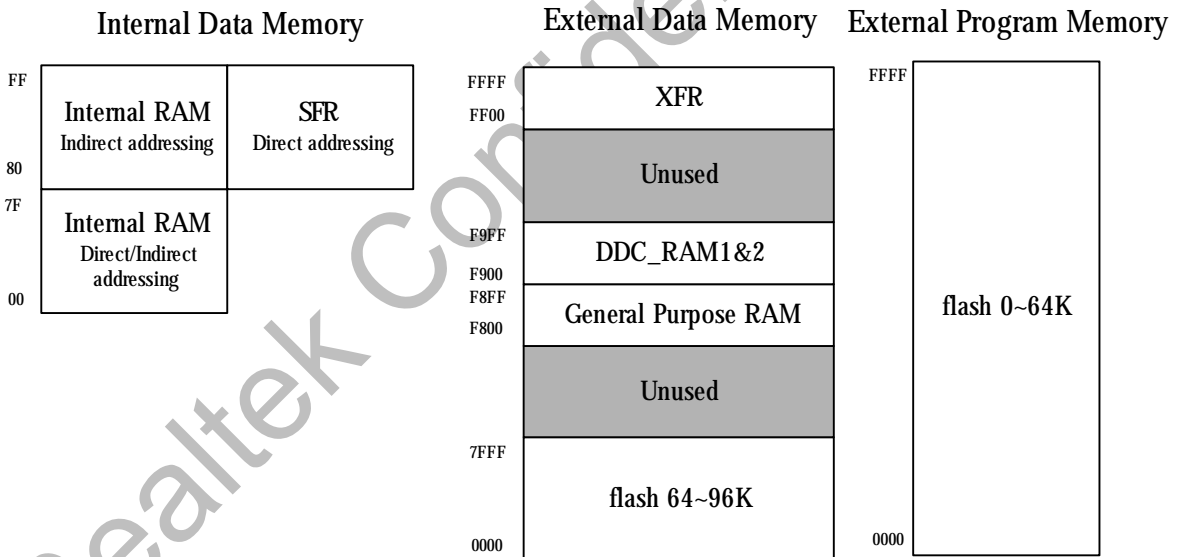

Reset

There are five reset sources in RTD2120, as described below:

- | RST pin
The external reset is high active and its pulse width must be larger than 16 mcu clock cycles. The RST pin can reset the whole chip of RTD2120.
- | Low voltage reset(LVR) and power on reset(POR)
The LVR and POR monitor the power status of RTD2120. The same as external reset, the LVR and POR will reset the whole chip of RTD2120 when triggered.
- | Software reset

To activate software reset, set FF39[1](SOF_RST). When software reset is triggered, it will reset all modules except debug mode.

I Watchdog timer(WDT)

The watchdog timer generates reset when it is overflowed. The watchdog timer resets almost the same modules as software reset except itself(watchdog timer module).

I In System Programming(ISP) reset

ISP reset will generate when entering ISP mode. Compared to Watchdog timer reset, ISP mode resets almost the same modules as Watchdog timer except itself(ISP module).

	Debug mode module	Watchdog timer module	CPU	ISP module and other modules
RST pin	O	O	O	O
LVR & POR	O	O	O	O
Software reset	x	O	O	O
WDT reset	x	x	O	x
ISP reset	x	x	O	x

Note: O = Reset , x = No effect

Interrupt

Six interrupts are provided in RTD2120. Four of these are generated automatically by internal operation: timer 0, timer 1, timer 2 and the serial port interrupt. The other two interrupts are triggered by external pins: INT0 and INT1. Moreover, the DDC and IIC interrupts are connected to DW8051 *INT1* source as the following figure.

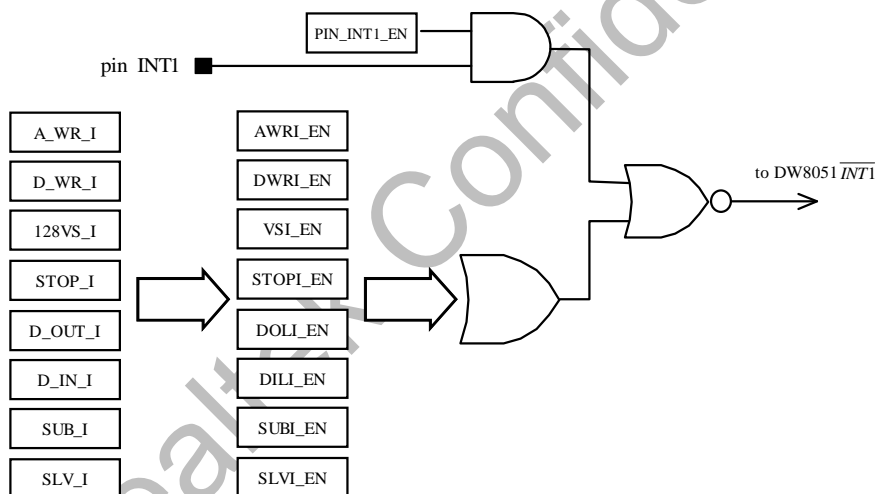

Timer/Counter

RTD2120 has three timers/counters: T0, T1 and T2. T0 and T1 are fully compatible to timer/counter in standard 8051's. Like timer2 in 8052, T2 of RTD2120 has three operating modes: 16-bit timer/counter with capture, 16-bit auto-reload timer/counter and Baud rate generator. However, T2 of RTD2120 does not support "Timer2 output enable(T2OE)" and "downcount enable(DCEN)". The SFRs associated with Timer2 are listed below.

Register	Bit 7	Bit 6	Bit 5	Bit 4	Bit 3	Bit 2	Bit 1	Bit 0	Addr
T2CON	TF2	EXF2	RCLK	TCLK	EXEN2	TR2	C/T2	CP/RL2	C8h
RCAP2L									CAh

RCAP2H									CBh
TL2									CCh
TH2									CDh

1. 16-bit timer/counter with capture

The Timer 2 capture mode is the same as the 16-bit timer/counter with the addition of the capture registers and control signals. If EXEN2 = 0, Timer2 is a 16-bit timer/counter . The C/T2 bit determines whether the 16-bit counter counts osc cycles (divided by 4 or 12), or high-to-low transitions on the P1.0 pin. The TR2 bit enables the counter. When the count increments from FFFFh, the TF2 flag is set.

The CP/RL2 bit in the T2CON SFR enables the capture feature. When CP/RL2 = 1, a high-to-low transition on P1.1 when EXEN2 = 1 causes the Timer 2 value to be loaded into the capture registers (RCAP2L and RCAP2H).

2. 16-bit timer/counter with auto-reload

When CP/RL2 = 0, Timer 2 is configured for the auto-reload mode. Control of counter input is the same as for the other 16-bit counter modes. When the count increments from FFFFh, Timer 2 sets the TF2 flag and the starting value is reloaded into TL2 and TH2. The software must preload the starting value into the RCAP2L and RCAP2H registers. When Timer 2 is in auto-reload mode, a reload can be forced by a high-to-low transition on the P1.1 pin, if enabled by EXEN2 = 1.

3. Baud rate generator

Setting either RCLK or TCLK to 1 configures Timer 2 to generate baud rates for Serial Port 0 in serial mode 1 or 3. In baud rate generator mode, Timer 2 functions in auto-reload mode. However, instead of setting the TF2 flag, the counter overflow generates a shift clock for the serial port function. As in normal auto-reload mode, the overflow also causes the preloaded start value in the RCAP2L and RCAP2H registers to be reloaded into the TL2 and TH2 registers. When either TCLK = 1 or RCLK = 1, Timer 2 is forced into auto-reload operation, regardless of the state of the CP/RL2 bit. When operating as a baud rate generator, Timer 2 does not set the TF2 bit. In this mode, a Timer 2 interrupt can only be generated by a high-to-low transition on the P1.1 pin setting the EXF2 bit, and only if enabled by EXEN2 = 1.

The counter time base in baud rate generator mode is osc/2. To use an external clock source, set C/T2 to 1 and apply the desired clock source to the P1.0 pin.

Special Function Registers(SFR)

Register	Bit 7	Bit 6	Bit 5	Bit 4	Bit 3	Bit 2	Bit 1	Bit 0	Reset Value (Hex)	Addr (Hex)
SP									07	81
DPL0									00	82
DPH0									00	83
DPL1									00	84
DPH1									00	85
DPS	0	0	0	0	0	0	0	SEL	00	86
PCON	SMOD0		1	1	GF1	GF0	STOP	IDLE	30	87
TCON	TF1	TR1	TF0	TR0	IE1	IT1	IE0	IT0	00	88
TMOD	GATE	C/T	M1	M0	GATE	C/T	M1	M0	00	89
TL0									00	8A

Register	Bit 7	Bit 6	Bit 5	Bit 4	Bit 3	Bit 2	Bit 1	Bit 0	Reset Value (Hex)	Addr (Hex)
TL1									00	8B
TH0									00	8C
TH1									00	8D
CKCON			T2M	T1M	T0M	MD2	MD1	MD0	01	8E
SPC_FNC	0	0	0	0	0	0	0	WRS	00	8F
P1	P1.7	P1.6	P1.5	P1.4	P1.3	P1.2	P1.1	P1.0	FF	90
MPAGE									00	92
P1_R	P1.7	P1.6	P1.5	P1.4	P1.3	P1.2	P1.1	P1.0	FF	93
SCON0	SM0	SM1	SM2	REN	TB8	RB8	TI	RI	00	98
SBUF0									00	99
P2	P2.7	P2.6	P2.5	P2.4	P2.3	P2.2	P2.1	P2.0	00	A0
IE	EA	0	ET2	ES0	ET1	EX1	ET0	EX0	00	A8
P3	P3.7	P3.6	P3.5	P3.4	P3.3	P3.2	P3.1	P3.0	FF	B0
P3_R	P3.7	P3.6	P3.5	P3.4	P3.3	P3.2	P3.1	P3.0	FF	B3
IP	1	0	PT2	PS0	PT1	PX1	PT0	PX0	80	B8
T2CON	TF2	EXF2	RCLK	TCLK	EXEN2	TR2	C/T2	CP/RL2	00	C8
RCAP2L									00	CA
RCAP2H									00	CB
TL2									00	CC
TH2									00	CD
PSW	CY	AC	F0	RS1	RS0	OV	F1	P	00	D0
ACC									00	E0
B									00	F0

External Special Function Registers(XFR)

Pin Share

Register::Pin_share0		0xFF00			
Name	Bits	Read/Write	Reset State	Comments	
Reserved	7	--	0	Reserved	
IIC2E	6	R/W	1	0: Pin "P5.6/DSCL" is P5.6, Pin "P5.7/DSDA" is P5.7 1: Pin "P5.6/DSCL" is DSCL, Pin "P5.7/DSDA" is DSDA	
PWM5E	5	R/W	0	0: Pin "P5.5/PWM5" is P5.5 1: Pin "P5.5/PWM5" is PWM5	
PWM4E	4	R/W	0	0: Pin "P5.4/PWM4" is P5.4 1: Pin "P5.4/PWM4" is PWM4	
PWM3E	3	R/W	0	0: Pin "P5.3/PWM3" is P5.3 1: Pin "P5.3/PWM3" is PWM3	
PWM2E	2	R/W	0	0: Pin "P5.2/PWM2" is P5.2 1: Pin "P5.2/PWM2" is PWM2	

PWM1E	1	R/W	0	0: Pin "P5.1/PWM1" is P5.1 1: Pin "P5.1/PWM1" is PWM1
PWM0E	0	R/W	0	0: Pin "P5.0/PWM0" is P5.0 1: Pin "P5.0/PWM0" is PWM0

Register::Pin_share1		0xFF01		
Name	Bits	Read/Write	Reset State	Comments
A_DDC_PIN_SEL	7	R/W	0	0: ADC DDC ports are connected to ASDA/ASCL 1: ADC DDC ports are connected to DSDA/DSCL
D_DDC_PIN_SEL	6	R/W	1	0: DVI DDC ports are connected to ASDA/ASCL 1: DVI DDC ports are connected to DSDA/DSCL
Reserved	5:3	--	0	Reserved
PIN_INT1_EN	2	R/W	1	Pin "P3.3/INT1" connect to 8051 INT1 enable 0: disable 1: enable when Pin "P3.3/INT1" is used as GPIO, this bit must be 0.
CLKO2E	1	R/W	0	0: Pin "P7.6/CLKO2" is P7.6 1: Pin "P7.6/CLKO2" is CLKO2
IIC1E	0	R/W	1	0: Pin "ASCL/P3.0/Rxd" is P3.0/RXD, Pin "ASDA/P3.1/Txd" is P3.1/TXD 1: Pin "ASCL/P3.0/Rxd" is ASCL, Pin "ASDA/P3.1/Txd" is ASDA

Register::Pin_share2		0xFF02		
Name	Bits	Read/Write	Reset State	Comments
Reserved	7:5	--	0	Reserved
CLKO1E	4	R/W	0	0: Pin "P6.6/CLKO1" is P6.6 1: Pin "P6.6/CLKO1" is CLKO1
ADC3E	3	R/W	0	0: Pin "P6.3/ADC3" is P6.3 1: Pin "P6.3/ADC3" is ADC3
ADC2E	2	R/W	0	0: Pin "P6.2/ADC2" is P6.2 1: Pin "P6.2/ADC2" is ADC2
ADC1E	1	R/W	0	0: Pin "P6.1/ADC1" is P6.1 1: Pin "P6.1/ADC1" is ADC1
ADC0E	0	R/W	0	0: Pin "P6.0/ADC0" is P6.0 1: Pin "P6.0/ADC0" is ADC0

I/O port

- 1 Each I/O pin of RTD2120 can drive/sink 4mA and the internal pull up/down circuit can drive/sink 10uA.

- I All pins have 5V tolerance except four ADC pins: “P6.0/ADC0”, “P6.1/ADC1”, “P6.2/ADC2” and ”P6.3/ADC3”.

Register::Port5_output_enable		0xFF03		
Name	Bits	Read/Write	Reset State	Comments
P57OE	7	R/W	0	0: P5.7 is input pin 1: P5.7 is output pin
P56OE	6	R/W	0	0: P5.6 is input pin 1: P5.6 is output pin
P55OE	5	R/W	0	0: P5.5 is input pin 1: P5.5 is output pin
P54OE	4	R/W	0	0: P5.4 is input pin 1: P5.4 is output pin
P53OE	3	R/W	0	0: P5.3 is input pin 1: P5.3 is output pin
P52OE	2	R/W	0	0: P5.2 is input pin 1: P5.2 is output pin
P51OE	1	R/W	0	0: P5.1 is input pin 1: P5.1 is output pin
P50OE	0	R/W	0	0: P5.0 is input pin 1: P5.0 is output pin

Register::Port6_output_enable		0xFF04		
Name	Bits	Read/Write	Reset State	Comments
P67OE	7	R/W	0	0: P6.7 is input pin 1: P6.7 is output pin
P66OE	6	R/W	0	0: P6.6 is input pin 1: P6.6 is output pin
P65OE	5	R/W	0	0: P6.5 is input pin 1: P6.5 is output pin
P64OE	4	R/W	0	0: P6.4 is input pin 1: P6.4 is output pin
P63OE	3	R/W	0	0: P6.3 is input pin 1: P6.3 is output pin
P62OE	2	R/W	0	0: P6.2 is input pin 1: P6.2 is output pin
P61OE	1	R/W	0	0: P6.1 is input pin 1: P6.1 is output pin
P60OE	0	R/W	0	0: P6.0 is input pin 1: P6.0 is output pin

Register::Port7_output_enable		0xFF05		
Name	Bits	Read/Write	Reset State	Comments
P77OE	7	R/W	0	0: P7.7 is input pin 1: P7.7 is output pin

P76OE	6	R/W	0	0: P7.6 is input pin 1: P7.6 is output pin
Reserved	5:0	--	0	Reserved

Register::Port1_pad_type 0xFF09				
Name	Bits	Read/Write	Reset State	Comments
P17_PPO	7	R/W	0	0:P1.7 is standar 8051 I/O 1:P1.7 is Push-Pull output
P16_PPO	6	R/W	0	0:P1.6 is standar 8051 I/O 1:P1.6 is Push-Pull output
P15_PPO	5	R/W	0	0:P1.5 is standar 8051 I/O 1:P1.5 is Push-Pull output
P14_PPO	4	R/W	0	0:P1.4 is standar 8051 I/O 1:P1.4 is Push-Pull output
P13_PPO	3	R/W	0	0:P1.3 is standar 8051 I/O 1:P1.3 is Push-Pull output
P12_PPO	2	R/W	0	0:P1.2 is standar 8051 I/O 1:P1.2 is Push-Pull output
P11_PPO	1	R/W	0	0:P1.1 is standar 8051 I/O 1:P1.1 is Push-Pull output
P10_PPO	0	R/W	0	0:P1.0 is standar 8051 I/O 1:P1.0 is Push-Pull output

Register::Port50_pin_reg 0xFF50				
Name	Bits	Read/Write	Reset State	Comments
Reserved	7:1	--	0	Reserved
P50	0	R/W	1	Input/output value of P5.0

Register::Port51_pin_reg 0xFF51				
Name	Bits	Read/Write	Reset State	Comments
Reserved	7:1	--	0	Reserved
P51	0	R/W	1	Input/output value of P5.1

Register::Port52_pin_reg 0xFF52				
Name	Bits	Read/Write	Reset State	Comments
Reserved	7:1	--	0	Reserved
P52	0	R/W	1	Input/output value of P5.2

Register::Port53_pin_reg 0xFF53				
Name	Bits	Read/Write	Reset State	Comments
Reserved	7:1	--	0	Reserved
P53	0	R/W	1	Input/output value of P5.3

Register::Port54_pin_reg 0xFF54				
Name	Bits	Read/Write	Reset State	Comments
Reserved	7:1	--	0	Reserved
P54	0	R/W	1	Input/output value of P5.4

Register::Port55_pin_reg 0xFF55				
Name	Bits	Read/Write	Reset State	Comments
Reserved	7:1	--	0	Reserved
P55	0	R/W	1	Input/output value of P5.5

Register::Port56_pin_reg 0xFF56				
Name	Bits	Read/Write	Reset State	Comments
Reserved	7:1	--	0	Reserved
P56	0	R/W	1	Input/output value of P5.6

Register::Port57_pin_reg 0xFF57				
Name	Bits	Read/Write	Reset State	Comments
Reserved	7:1	--	0	Reserved
P57	0	R/W	1	Input/output value of P5.7

Register::Port60_pin_reg 0xFF58				
Name	Bits	Read/Write	Reset State	Comments
Reserved	7:1	--	0	Reserved
P60	0	R/W	1	Input/output value of P6.0

Register::Port61_pin_reg 0xFF59				
Name	Bits	Read/Write	Reset State	Comments
Reserved	7:1	--	0	Reserved
P61	0	R/W	1	Input/output value of P6.1

Register::Port62_pin_reg 0xFF5A				
Name	Bits	Read/Write	Reset State	Comments
Reserved	7:1	--	0	Reserved
P62	0	R/W	1	Input/output value of P6.2

Register::Port63_pin_reg 0xFF5B				
Name	Bits	Read/Write	Reset State	Comments
Reserved	7:1	--	0	Reserved
P63	0	R/W	1	Input/output value of P6.3

Register::Port64_pin_reg 0xFF5C				
Name	Bits	Read/Write	Reset State	Comments
Reserved	7:1	--	0	Reserved
P64	0	R/W	1	Input/output value of P6.4

Register::Port65_pin_reg 0xFF5D				
Name	Bits	Read/Write	Reset State	Comments
Reserved	7:1	--	0	Reserved
P65	0	R/W	1	Input/output value of P6.5

Register::Port66_pin_reg 0xFF5E				
Name	Bits	Read/Write	Reset State	Comments
Reserved	7:1	--	0	Reserved
P66	0	R/W	1	Input/output value of P6.6

Register::Port67_pin_reg 0xFF5F				
Name	Bits	Read/Write	Reset State	Comments
Reserved	7:1	--	0	Reserved
P67	0	R/W	1	Input/output value of P6.7

Register::Port76_pin_reg 0xFF60				
Name	Bits	Read/Write	Reset State	Comments
Reserved	7:1	--	0	Reserved
P76	0	R/W	1	Input/output value of P7.6

Register::Port77_pin_reg 0xFF61				
Name	Bits	Read/Write	Reset State	Comments
Reserved	7:1	--	0	Reserved
P77	0	R/W	1	Input/output value of P7.7

Low Voltage Reset & Power on Reset

When the voltage level of power supply is below V_{LT} , the low voltage reset(LVR) generates a chip reset signal. After the power supply is above $V_{UT}(2.6V)$, LVR remain in reset state for 65536 X'tal cycle(t_{POR}) to guarantee the chip exit reset condition.

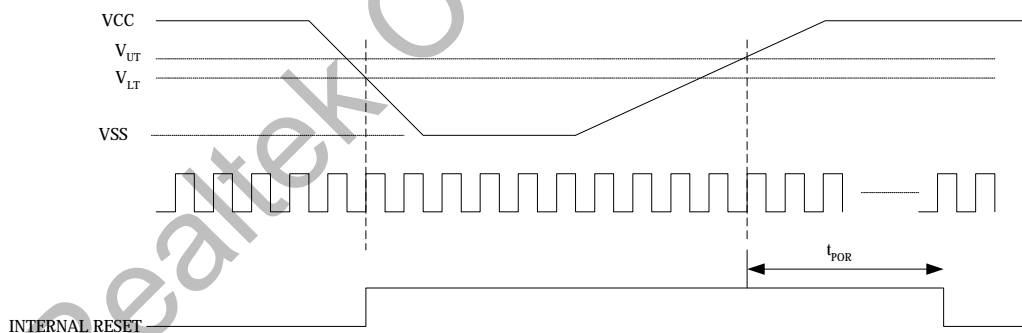

Register::LVR_control 0xFF0A				
Name	Bits	Read/Write	Reset State	Comments

VLT	7:6	R/W	0	low_threshold_voltage 00:1.8V 01:2.0V 10:2.2V 11:2.4V
reserved	5:0	--	00	reserved

A/D Converter

RTD2120 has embedded 4 channels of analog-to-digital converter. The ADCs convert analog input voltage on the four A/D input pins to four 6-bit digital data stored in XFRs (FF0C~FF0F) sequentially.

The ADC conversion range is from GND to VDD and the conversion is linear and monotonic with no missing codes. To start A/D conversion, set STRT_ADC(FF0B[7]) = 1 and the conversion will be complete in less than 12 us for 4 channels.

Register::ADC_control		0xFF0B		
Name	Bits	Read/Write	Reset State	Comments
STRT_ADC	7	R/W	0	Write 1 to start the A/D conversion. Auto clear when A/D Conversion has been completed. 0:A/D Conversion has been completed 1:A/D Conversion is not completed yet
ADC_TEST	6	R/W	0	0: Normal operation 1: ADC test mode
reserved	5:3	R/W	0	Reserved
BIAS_ADJ	2:1	R/W	1	ADC bias current adjust 00: 15u 01: 20u 10: 25u 11: 30u
CK_SEL	0	R/W	0	Inverse ADC input clock pos/neg 0: pos 1: neg

Register::ADC0_convert_result		0xFF0C		
Name	Bits	Read/Write	Reset State	Comments
ADC0_CONV_DATA	7:2	R	3F	Converted data of ADC0
reserved	1:0	--	00	

Register::ADC1_convert_result		0xFF0D		
-------------------------------	--	--------	--	--

Name	Bits	Read/Write	Reset State	Comments
ADC1_CONV_DATA	7:2	R	3F	Converted data of ADC1
reserved	1:0	--	00	

Register::ADC2_convert_result				0xFF0E
Name	Bits	Read/Write	Reset State	Comments
ADC2_CONV_DATA	7:2	R	3F	Converted data of ADC2
reserved	1:0	--	00	

Register::ADC3_convert_result				0xFF0F
Name	Bits	Read/Write	Reset State	Comments
ADC3_CONV_DATA	7:2	R	3F	Converted data of ADC3
reserved	1:0	--	00	

PLL

RTD2120 contains a PLL to make the whole chip operate at higher or lower speed for different demands. After reset, RTD2120 uses crystal frequency as the system clock. User can program the PLL to operate at the desired frequency and select system clock to PLL output by setting MCU_CLK_SEL. RTD2120 will switch system clock to PLL output only when PLL is stable. Moreover, the divider is glitch free so user can modify its value at any time. For normal operation, user must choose the crystal whose frequency is between 11M and 27MHz. Besides, VCO frequency must be programmed between 40M and 80MHz.

Note: $F_{vco} = X_{tal} * (M/N)$, where $M=M_code+1$, $N=N_code+1$.

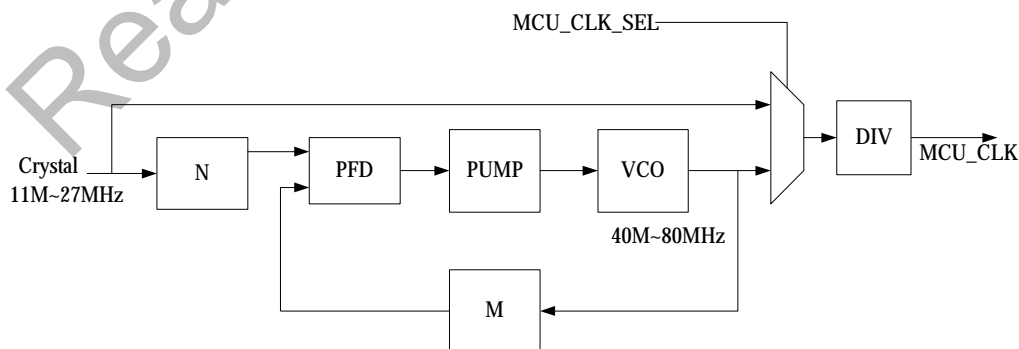

Register::PLL_control				0xFF10
Name	Bits	Read/Write	Reset State	Comments
PLL_STA	7	R	1	PLL status 0: normal operation 1: PLL abnormal or PLL power down
DVSET	6:5	R/W	2	Test mode vctrl set 11(0.8v) 10(1.0v) 01(1.2v) 00(1.4v)
reserved	4:3	--	0	
WD_RST	2	R/W	0	0: No effect 1: Watchdog reset
WD_SET	1	R/W	0	0: No effect 1: Watchdog set
PWDN_PLL	0	R/W	1	0: normal operation 1: power down PLL

Register::PLL_filter_control				0xFF11
Name	Bits	Read/Write	Reset State	Comments
reserved	7:4	--	0	
VR	3:2	R/W	0	Loop filter resistor 00: 16.32k 01: 19.12k 10: 21.92k 11: 24.72k
PLL_IP	1:0	R/W	2	Charge Pump current Ich=5u+bit[1]*10u+ bit[0]*5u

Register::PLL_M_N_DIV				0xFF12
Name	Bits	Read/Write	Reset State	Comments
M_CODE	7:4	R/W	1	Actual M = M_CODE+1
N_CODE	3:2	R/W	0	Actual N = N_CODE+1
DIV	1:0	R/W	0	Divider value 00:1 01:1/2 10:1/4 11:1/8

3.3V to 1.8V Regulator

	max	typ	min
Input voltage(V)			2
Output current(mA)	80		

Register::regulator_control		0xFF13		
Name	Bits	Read/Write	Reset State	Comments
reserved	7:5	--	0	
VBG	4:3	R/W	1	bandgap voltage select 00: 1.14v 01: 1.20v 10: 1.27v 11: 1.34v
V_SEL	2:0	R/W	4	Regulator 1.8v voltage select 000: 2.22 001: 2.12 010: 2.0 011: 1.9 100: 1.8 101: 1.7 110: 1.6 111: 1.5

DDC

RTD2120 has two DDC ports for both D-sub and DVI interface. The external master can access DDC_RAM1(F900~F97F) through pin ASDL and ASDA by ADC DDC channel or DDC_RAM2 (F980~F9FF) through pin DSDL and DSDA by DVI DDC channel. Besides, the DDC_RAM1 and DDC_RAM2 can be combined together to form a 256-bytes DDC_RAM for just ADC/DVI DDC slave by setting DDCRAM_SIZ (FF26[1:0]).

The DDC of RTD2120 is compliant with VESA DDC standard. Both DDC slaves are in DDC1 mode after reset. When a high to low transition is detected on ASCL/DSCL pin, the DDC slave will enter DDC2 transition mode. The DDC slave can revert to DDC1 mode if the SCL signal keeps unchanged for 128 VSYNC periods in DDC2 transition mode and RVT_A_DDC1_EN / RVT_D_DDC1_EN = 1. In DDC2 transition mode, the DDC slave will lock in DDC2 mode if a valid control byte is received. Furthermore, user can force the DDC slave to operate DDC2 mode by setting A_DDC2 / D_DDC2 = 1.

(Refers to the VESA "Display Data Channel Standard" for detailed)

Register::ADC_DDC_enable		0xFF20		
Name	Bits	Read/Write	Reset State	Comments
A_DDC_ADD R	7:5	R/W	0	ADC DDC Channel Address Least Significant 3 Bits (The default DDC channel address MSB 4 Bits is "A")
reserved	4	--	0	Reserved
A_DDC_W_S TA	3	R/W	0	ADC DDC Write Status (for external DDC access only) It is cleared after write.
A_DDCRAM _W_EN	2	R/W	0	ADC DDC SRAM Write Enable (for external DDC access only)

				0: Disable 1: Enable
A_DBN_EN	1	R/W	1	ADC DDC De-bounce Enable 0: Disable 1: Enable (with crystal/4)
A_DDC_EN	0	R/W	0	ADC DDC Channel Enable Bit 0: MCU access Enable 1: DDC channel Enable

Register::ADC_DDC_control				0xFF21
Name	Bits	Read/Write	Reset State	Comments
A_DBN_CLK_SEL	7:6	R/W	0	De-bounce clock divider 00: 1/1 reference clock 01: 1/2 reference clock 1X: 1/4 reference clock
A_STOP_DB_N_SEL	5:4	R/W	0	De-bounce sda stage 0X: latch one stage 10: latch two stage 11: latch three stage
A_SYS_CK_SEL	3	R/W	0	De-bounce reference clock 0: crystal clock 1: PLL clock
A_DDC2	2	R/W	0	Force to ADC DDC to DDC2 mode 0: Normal operation 1: DDC2 is active
RST_A_DDC	1	R/W	0	Reset ADC DDC circuit 0: Normal operation 1: reset (auto cleared)
RVT_A_DDC1_EN	0	R/W	0	ADC DDC revert to DDC1 enable(SCL idle for 128 VSYNC) 0: Disable 1: Enable

Register::DVI_DDC_enable				0xFF23
Name	Bits	Read/Write	Reset State	Comments
D_DDC_ADDR	7:5	R/W	0	DVI DDC Channel Address Least Significant 3 Bits (The default DDC channel address MSB 4 Bits is "A")
reserved	4	--	0	Reserved
D_DDC_W_STA	3	R/W	0	DVI DDC External Write Status (for external DDC access only) It is cleared after write.
D_DDCRAM_W_EN	2	R/W	0	DVI DDC External Write Enable (for external DDC access only) 0: Disable 1: Enable
D_DBN_EN	1	R/W	1	DVI DDC Debounce Enable 0: Disable 1: Enable (with crystal/4)

D_DDC_EN	0	R/W	0	DVI DDC Channel Enable Switch 0: MCU access Enable 1: External DDC access Enable
----------	---	-----	---	--

Register::DVI_DDC_control				0xFF24
Name	Bits	Read/Write	Reset State	Comments
D_DBN_CLK_SEL	7:6	R/W	0	De-bounce clock divider 00: 1/1 reference clock 01: 1/2 reference clock 1X: 1/4 reference clock
D_STOP_DB_N_SEL	5:4	R/W	0	De-bounce sda stage 0X: latch one stage 10: latch two stage 11: latch three stage
D_SYS_CK_SEL	3	R/W	0	De-bounce reference clock 0: crystal clock 1: PLL clock
D_DDC2	2	R/W	0	Force to DVI DDC to DDC2 mode 0: Normal operation 1: DDC2 is active
RST_D_DDC	1	R/W	0	Reset DVI DDC circuit 0: Normal operation 1: reset (auto cleared)
RVT_D_DDC1_EN	0	R/W	0	DVI DDC revert to DDC1 enable(SCL idle for 128 VSYNC) 0: Disable 1: Enable

Register::DDCRAM_partition				0xFF26
Name	Bits	Read/Write	Reset State	Comments
reserved	7:3	--	00	Reserved
VS_CON	2	R/W	0	0: VSYNC signal is connected to ADC DDC 1: VSYNC signal is connected to DVI DDC
DDCRAM_SIZE	1:0	R/W	0	0x:ADC DDCRAM=128 byte, DVI DDCRAM=128 byte 10:ADC DDCRAM=0 byte, DVI DDCRAM=256 byte 11:ADC DDCRAM=256 byte, DVI DDCRAM=0 byte

IIC Interface

Register::IIC_set_slave				0xFF27
-------------------------	--	--	--	--------

Name	Bits	Read/Write	Reset State	Comments
IIC_ADDR	7:1	R/W	37	IIC Slave Address to decode
CH_SEL	0	R/W	0	Channel Select 0: from ADC DDC 1: from DVI DDC

Register::IIC_sub_in**0xFF28**

Name	Bits	Read/Write	Reset State	Comments
IIC_SUB_ADDR	7:0	R	00	IIC Sub-Address Received

Register::IIC_data_in**0xFF29**

Name	Bits	Read/Write	Reset State	Comments
IIC_D_IN	7:0	R	00	IIC data received

Register::IIC_data_out**0xFF2A**

Name	Bits	Read/Write	Reset State	Comments
IIC_D_OUT	7:0	W	00	IIC data to be transmitted

Register::IIC_status**0xFF2B**

Name	Bits	Read/Write	Reset State	Comments
A_WR_I	7	R/W	0	If ADC DDC detects a STOP condition in write mode, this bit is set to "1". Write 0 to clear.
D_WR_I	6	R/W	0	If DVI DDC detects a STOP condition in write mode, this bit is set to "1". Write 0 to clear.
128VS_I	5	R/W	0	In DDC2 Transition mode, SCL idle for 128 VSYNC. Write 0 to clear.
STOP_I	4	R/W	0	If IIC detects a STOP condition(slave address must match), this bit is set to "1". Write 0 to clear.
D_OUT_I	3	R	0	If IIC_DATA_OUT loaded to serial-out-byte, this bit is set to "1". Write IIC_data_out (FF2A) to clear.
D_IN_I	2	R	0	If IIC_DATA_IN latched, this bit is set to "1". Read IIC_data_in (FF29) to clear.
SUB_I	1	R/W	0	If IIC_SUB latched, this bit is set to "1". Write 0 to clear.

SLV_I	0	R/W	0	If IIC_SLAVE latched, this bit is set to "1" Write 0 to clear.
-------	---	-----	---	---

Register::IIC_IRQ_control				0xFF2C
Name	Bits	Read/Write	Reset State	Comments
AWI_EN	7	R/W	0	0: Disable the A_WR_I signal as an interrupt source 1: Enable the A_WR_I signal as an interrupt source
DWI_EN	6	R/W	0	0: Disable the D_WR_I signal as an interrupt source 1: Enable the D_WR_I signal as an interrupt source
128VSI_EN	5	R/W	0	0: Disable the 128VS_I signal as an interrupt source 1: Enable the 128VS_I signal as an interrupt source
STOPI_EN	4	R/W	0	0: Disable the STOP_I signal as an interrupt source 1: Enable the STOP_I signal as an interrupt source
DOI_EN	3	R/W	0	0: Disable the D_OUT_I signal as an interrupt source 1: Enable the D_OUT_I signal as an interrupt source
DII_EN	2	R/W	0	0: Disable the D_IN_I signal as an interrupt source 1: Enable the D_IN_I signal as an interrupt source
SUBI_EN	1	R/W	0	0: Disable the SUB_I signal as an interrupt source 1: Enable the SUB_I signal as an interrupt source
SLVI_EN	0	R/W	0	0: Disable the SLV_I signal as an interrupt source 1: Enable the SLV_I signal as an interrupt source

PWM

RTD2120 supports 3 channels of PWM DAC. The resolution of each PWM is 8-bit. PWM0, PWM1 and PWM2 are connected to DA0, DA1 and DA2 respectively. Meanwhile, they can also be connected to DA3, DA4 and DA5 which are programmed via PWM_source_select register. The figure below represent the PWM clock generator. Based on the clock, we make up the PWM waveform which frequency is 1/256 of the PWM clock.

PWM clock generator

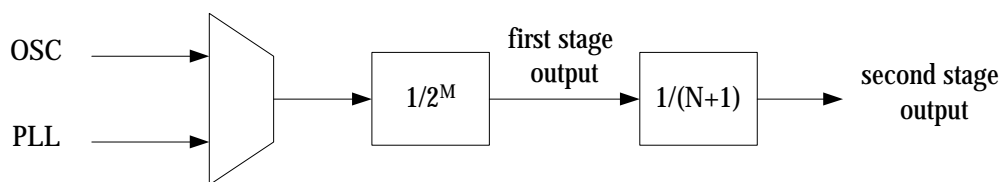

Register::PWM_clock_control		0xFF30		
Name	Bits	Read/Write	Reset State	Comments
PWM_EN	7	R/W	0	0: Disable PWM output 1: Enable PWM output
PWM0_CK	6	R/W	0	0: Select first stage output 1: Select second stage output
PWM1_CK	5	R/W	0	0: Select first stage output 1: Select second stage output
PWM2_CK	4	R/W	0	0: Select first stage output 1: Select second stage output
PWM_CK_SEL	3	R/W	0	PWM clock generator input source 0: Crystal 1: PLL output
reserved	2	--	0	Reserved
PWM_M	1:0	R/W	0	PWM clock first stage divider

Register::PWM_divider_N		0xFF31		
Name	Bits	Read/Write	Reset State	Comments
PWM_N	7:0	R/W	0	PWM clock Second stage divider

Register::PWM0_duty_width		0xFF32		
Name	Bits	Read/Write	Reset State	Comments
PWM0_DUT	7:0	R/W	0	PWM0 duty width

Register::PWM1_duty_width		0xFF33		
Name	Bits	Read/Write	Reset State	Comments
PWM1_DUT	7:0	R/W	0	PWM1 duty width

Register::PWM2_duty_width		0xFF34		
Name	Bits	Read/Write	Reset State	Comments
PWM2_DUT	7:0	R/W	0	PWM2 duty width

Register::PWM_source_select		0xFF35		
Name	Bits	Read/Write	Reset State	Comments
reserved	7:6	--	0	Reserved
PWM5_SEL	5:4	R/W	2	00: PWM5 is the same as PWM0 01: PWM5 is the same as PWM1 1x: PWM5 is the same as PWM2
PWM4_SEL	3:2	R/W	1	00: PWM4 is the same as PWM0 01: PWM4 is the same as PWM1 1x: PWM4 is the same as PWM2
PWM3_SEL	1:0	R/W	0	00: PWM3 is the same as PWM0 01: PWM3 is the same as PWM1 1x: PWM3 is the same as PWM2

Watchdog Timer

The Watchdog Timer automatically generates a device reset when it is overflowed. The interval of overflow is about 0.25 sec to 2 sec (assume crystal is 12MHz) and can be programmed via register CNT1.

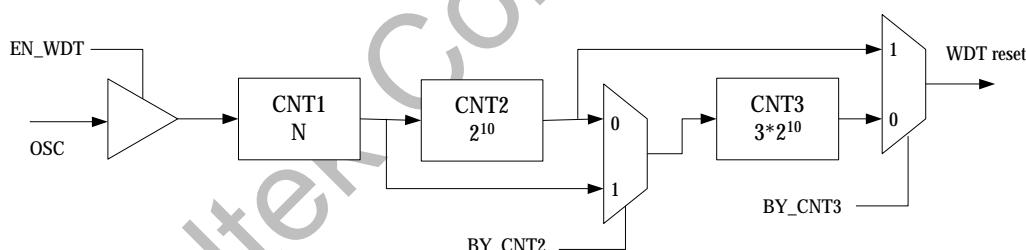

Register::WATCHDOG_timer		0xFF36		
Name	Bits	Read/Write	Reset State	Comments
WDT_EN	7	R/W	0	0: Disable watchdog timer 1: Enable watchdog timer
CLR_WDT	6	W	0	0: No effect 1: Clear all counters of watchdog
BY_CNT2	5	R/W	0	Signal bypass counter2* 0: signal pass through counter2 1: bypass
BY_CNT3	4	R/W	0	Signal bypass counter3* 0: signal pass through counter3

				1: bypass
reserved	3	--	0	Reserved
CNT1	2:0	R/W	0	The number N of counter1 000~111: 1~8

! When ISP mode is enabled, watchdog will be disabled by hardware.

*When BY_CNT2 and BY_CNT3 are all assigned one (bypass), watchdog will be counted by CNT2

In System Programming

User can program the embedded 96K flash of RTD2120 by internal hardware without removing RTD2120 from the system. RTD2120 utilizes DDC channel (ADC/DVI DDC) to communicate with IIC host for ISP function. The ISP protocol is mainly compatible with DDC protocol. However, one significant difference is that the LSB of 7-bit ISP address is the address auto increase bit. Thus, we can improve the flash program speed.

Register::ISP_slave_address				0xFF37
Name	Bits	Read/Write	Reset State	Comments
ISP_ADDR	7:2	R/W	25	ISP slave address
ISP_ADDR_I NC_A	1	R	1	Received LSB of ISP slave address of ADC DDC channel 0: address is nonincrease 1: address is auto-increase
ISP_ADDR_I NC_D	0	R	1	Received LSB of ISP slave address of DVI DDC channel 0: address is nonincrease 1: address is auto-increase

Register::option				0xFF38
Name	Bits	Read/Write	Reset State	Comments
PORT_PIN_R EG	7	R/W	1	port_pin_reg_n enable 0: port_pin_reg_n signal is disabled 1: port_pin_reg_n signal is enabled
reserved	6:2	--	0	Reserved
MCU_CLK_S EL	1	R/W	0	CPU clock source select 0: CPU clock is from Crystal divided by DIV 1: CPU clock is from PLL divided by DIV
CKOUT_SEL	0	R/W	0	CLKO1 & CLKO2 select 0: Select Crystal output 1: Select PLL output

Register::flash_page_erase_control				0xFF39
Name	Bits	Read/Write	Reset State	Comments

PAGE_ADDR	7:3	R/W	00	Flash page address from 64K to 96K
reserved	2	--	0	Reserved
SOF_RST	1	R/W	0	Software reset for debug mode 0: No effect 1: reset RTD2120
STR_P_ERS	0	R/W	0	Start page erase 0: page erase complete 1: write 1 to start page erase

Register::RAM_test		0xFF3A		
Name	Bits	Read/Write	Reset State	Comments
reserved	7:4	--	0	Reserved
EXT_RAM_BIST	3	R/W	0	Start BIST function for MCU external RAM (512 bytes) 0: finished and clear 1: start
EXT_RAM_STATUS	2	R	0	Test result about MCU external RAM 0: fail 1: ok
INT_RAM_BIST	1	R/W	0	Start BIST function for MCU internal RAM (256 bytes) 0: finished and clear 1: start
INT_RAM_STATUS	0	R	0	Test result about MCU internal RAM 0: fail 1: ok

Memory map of XFR

Register name	Addr	Bit7	Bit6	Bit5	Bit4	Bit3	Bit2	Bit1	Bit0	
Pin_share0	FF00		IIC2E	PWM5E	PWM4E	PWM3E	PWM2E	PWM1E	PWM0E	
Pin_share1	FF01	A_DDC_P IN_SEL	D_DDC_P IN_SEL				PIN_INT1 _EN	CLKO2E	IIC1E	
Pin_share2	FF02				CLKO1E	ADC3E	ADC2E	ADC1E	ADC0E	
Port5_output_enabl e	FF03	P57OE	P56OE	P55OE	P54OE	P53OE	P52OE	P51OE	P50OE	
Port6_output_enabl e	FF04	P67OE	P66OE	P65OE	P64OE	P63OE	P62OE	P61OE	P60OE	
Port7_output_enabl e	FF05	P77OE	P76OE							
Port1_pad_type	FF09	P17_PPO	P16_PPO	P15_PPO	P14_PPO	P13_PPO	P12_PPO	P11_PPO	P10_PPO	
LVR_control	FF0A	VLT								
ADC_control	FF0B	STRT_AD C	ADC_TES T				BIAS_ADJ		CK_SEL	
ADC0_convert_resul t	FF0C	ADC0_CONV_DATA								
ADC1_convert_resul t	FF0D	ADC1_CONV_DATA								
ADC2_convert_resul t	FF0E	ADC2_CONV_DATA								
ADC3_convert_resul t	FF0F	ADC3_CONV_DATA								
PLL_control	FF10	PLL_STA	DVSET				WD_RST	WD_SET	PWDN_P LL	
PLL_filter_control	FF11					VR		PLL_IP		
PLL_M_N_DIV	FF12	M_CODE				N_CODE		DIV		
Regulator_control	FF13				VBG		V_SEL			
ADC_DDC_enable	FF20	A_DDC_ADDR				A_DDC_ W_STA	A_DDCR AM_W_E N	A_DBN_E N	A_DDC_E N	
ADC_DDC_control 1	FF21	A_DBN_CLK_SEL		A_STOP_DBN_SEL		A_SYS_C K_SEL	A_DDC2	RST_A_D DC	RVT_A_D DC1_EN	
DVI_DDC_enable	FF23	D_DDC_ADDR				D_DDC_ W_STA	D_DDCR AM_W_E N	D_DBN_E N	D_DDC_E N	
DVI_DDC_control	FF24	D_DBN_CLK_SEL		D_STOP_DBN_SEL		D_SYS_C K_SEL	D_DDC2	RST_D_D DC	RVT_D_D DC1_EN	
DDCRAM_partitio n	FF26						VS_CON	DDCRAM_SIZ		
IIC_set_slave	FF27	IIC_ADDR							CH_SEL	
IIC_sub_in	FF28	IIC_SUB_ADDR								
IIC_data_in	FF29	IIC_D_IN								
IIC_data_out	FF2A	IIC_D_OUT								

Register name	Addr	Bit7	Bit6	Bit5	Bit4	Bit3	Bit2	Bit1	Bit0	
IIC_status	FF2B	A_WR_I	D_WR_I	128VS_I	STOP_I	D_OUT_I	D_IN_I	SUB_I	SLV_I	
IIC_IRQ_control	FF2C	AWI_EN	DWI_EN	128VSI_E N	STOPI_E N	DOI_EN	DII_EN	SUBI_EN	SLVI_EN	
PWM_clock_control	FF30	PWM_EN	PWM0_C K	PWM1_C K	PWM2_C K	PWM_CK _SEL		PWM_M		
PWM_divider_N	FF31	PWM_N								
PWM0_duty_width	FF32	PWM0_DUT								
PWM1_duty_width	FF33	PWM1_DUT								
PWM2_duty_width	FF34	PWM2_DUT								
PWM_source_select	FF35			PWM5_SEL		PWM4_SEL		PWM3_SEL		
WATCHDOG_timer	FF36	WDT_EN	CLR_WD T	BY_CNT2	BY_CNT3		CNT1			
ISP_slave_address	FF37	ISP_ADDR						ISP_ADD R_INC_A	ISP_ADD R_INC_D	
option	FF38	PORT_PI N_REG						MCU_CL K_SEL	CKOUT_ SEL	
Flash_page_erase_control	FF39	PAGE_ADDR						SOF_RST	STR_P_E RS	
RAM_test	FF3A					EXT_RA M_BIST	EXT_RA M_STA	INT_RAM _BIST	INT_RAM _STA	

Electric Specification

DC Characteristics

Table 1 Absolute Maximum Ratings

PARAMETER	SYMBOL	MIN	TYP	MAX	UNITS
Voltage on VDD	V_{VDD}	-1		4.6	V
Voltage on Input (5V tolerant)	V_{INI}	-1		5.5	V
Voltage on Output or I/O or NC	V_{IO}	-1		4.6	V
Electrostatic Discharge	V_{ESD}			±3.5	kV
Latch-Up	I_{LA}			±100	mA
Ambient Operating Temperature	T_A	0		70	°C
Storage temperature (plastic)	T_{STG}	-55		125	°C

Table 2 DC Characteristics/Operating Condition

(0°C < T_A < 70°C; $V_{DD} = 3.3V \pm 0.3V$)

PARAMETER	SYMBOL	MIN	TYP	MAX	UNITS
Supply Voltage	VDD	3.0	3.3	3.6	V
Supply Current	I_{VDD}		22 ⁽¹⁾	31 ⁽²⁾	mA
Supply Current(Power Saving)	I_{VDD}				mA
Output High Voltage	V_{OH}	2.4		VDD	V
Output Low Voltage	V_{OL}	GND		0.5	V
Input High Voltage	V_{IH}	2.0			V
Input Low Voltage	V_{IL}			0.8	V
I/O Pull-up resistance	R_{PU}	100		300	Ω
I/O Pull-down resistance	R_{PD}	50		150	Ω
Input Leakage Current($V_I = V_{CC}$ or GND)	I_{LI}	-10		+10	μA
Output Leakage Current($V_O = V_{CC}$ or GND)	I_{LO}	-20		+20	μA

(1) MCU operate at 24M Hz without any clock output.

(2) MCU operate at 48M Hz with PLL active and two clock outputs.

Mechanical Specification
48 Pin LQFP

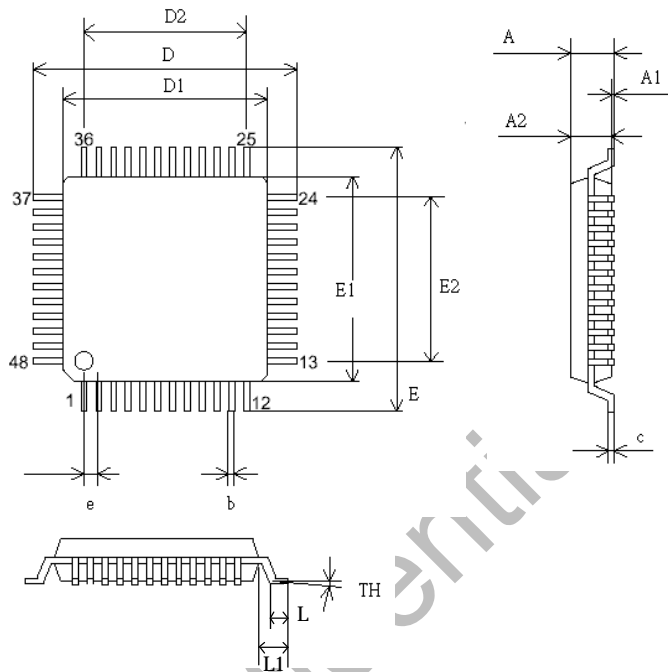

SYMBOL	MILLIMETER			INCH		
	MIN.	TYPICAL	MAX.	MIN.	TYPICAL	MAX.
A			1.60			0.063
A1	0.05		0.15	0.002		0.006
A2	1.35	1.40	1.45	0.053	0.055	0.057
c	0.09		0.20	0.004		0.008
D	9.00 BSC			0.354 BSC		
D1	7.00 BSC			0.276 BSC		
D2	5.50			0.217		
E	9.00 BSC			0.354 BSC		
E1	7.00 BSC			0.276 BSC		
E2	5.50			0.217		
b	0.17	0.20	0.27	0.007	0.008	0.011
e	0.50 BSC			0.0196 BSC		
TH	0o	3.5o	7o	0o	3.5o	7o
L	0.45	0.60	0.75	0.018	0.0236	0.030
L1		1.00			0.0393	

TITLE: LQFP-48 (7.0x7.0x1.6mm) PACKAGE OUTLINE DRAWING, FOOTPRINT 2.0mm		
LEADFRAME MATERIAL		
APPROVE	DOC. NO.	
	VERSION	02
CHECK	DWG NO	PKGC-065
	DATE	
REALTEK SEMICONDUCTOR CORP.		

44 Pin PLCC

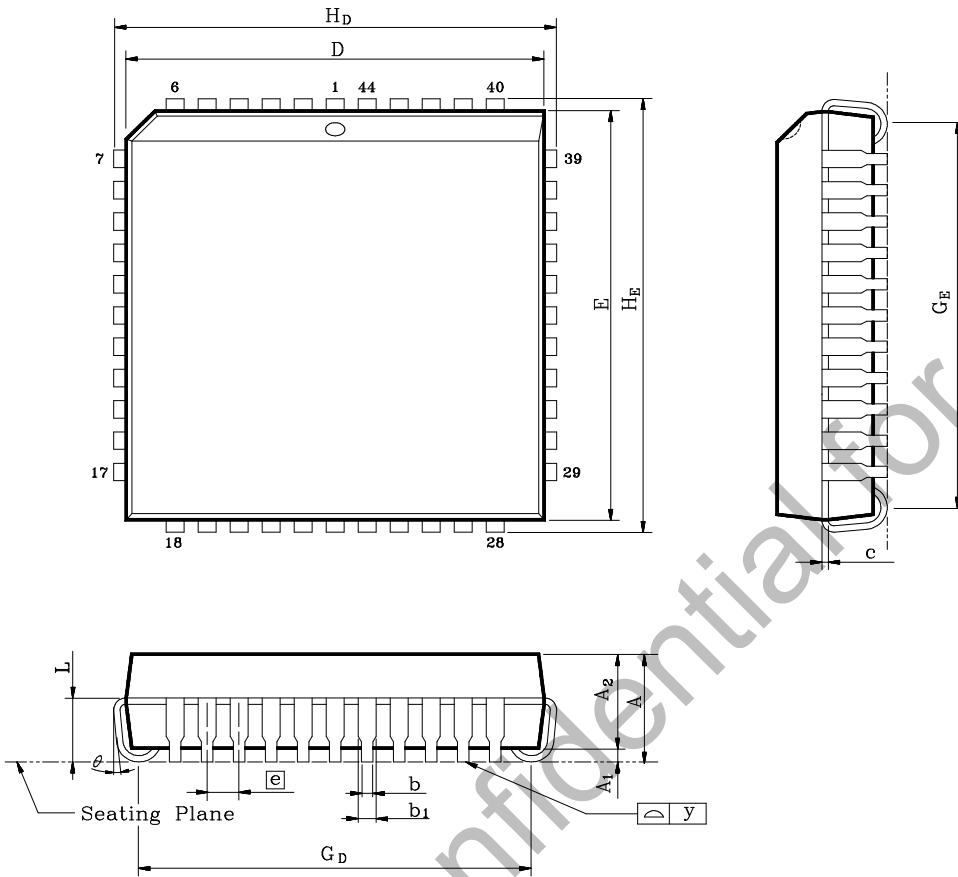

Symbol	Dimension in inch			Dimension in mm		
	Min	Typ	Max	Min	Typ	Max
A	—	—	0.185	—	—	4.70
A1	0.020	—	—	0.51	—	—
A2	0.140	0.150	0.160	3.56	3.81	4.06
b1	0.020	0.028	0.036	0.51	0.71	0.91
b	0.014	0.018	0.022	0.36	0.46	0.56
c	0.006	0.010	0.014	0.15	0.25	0.36
D	0.646	0.653	0.660	16.41	16.59	16.74
E	0.646	0.653	0.660	16.41	16.59	16.74
e	0.05 BSC			1.27 BSC		
GD	0.590	0.610	0.630	14.98	15.49	16.00
GE	0.590	0.610	0.630	14.98	15.49	16.00
HD	0.675	0.690	0.715	17.15	17.53	18.16
HE	0.675	0.690	0.715	17.15	17.53	18.16
L	0.085	0.100	0.115	2.16	2.54	2.92
y	—	—	0.004	—	—	0.10
θ	0°	—	10°	0°	—	10°

Note:

- 1.Dimension D & E do not include interlead flash.
- 2.Dimension b1 does not include dambar protrusion/intrusion.
- 3.Controlling dimension: Inch
- 4.General appearance spec. should be based on final visual inspection spec.

TITLE : 44L PLCC (0.653" X 0.653")			
PACKAGE OUTLINE DRAWING			
LEADFRAME MATERIAL:			
APPROVE		DOC. NO.	510-ASS-P004
		VERSION	1
		PAGE	17 OF 22
CHECK	Albert Chang	DWG. NO.	L044 - 1
		DATE	MAR. 08.2005
REALTEK SEMI-CONDUCTOR CO., LTD			

Ordering Information:

The available RTD2120 related products are listed below:

Part No.	Flash Size	Package Type
RTD2120K	96K byte	44 QFP
RTD2120L	96K byte	48 LQFP
RTD2120S	96K byte	44 PLCC
RTD2120L-LF	96K byte	48 LQFP (lead free)
RTD2120S-LF	96K byte	44 PLCC (lead free)