

RoHS  
Compliant

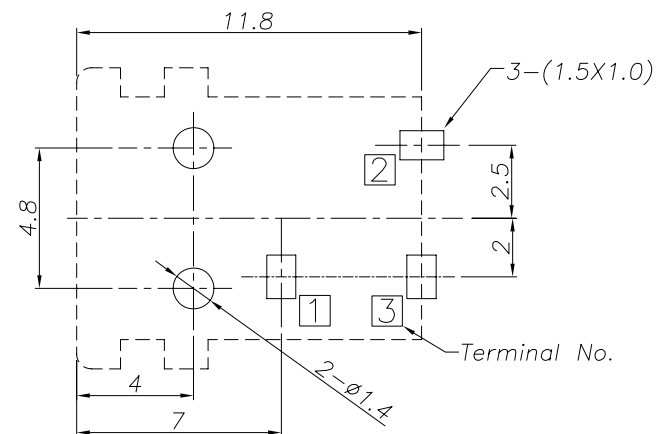

Recommended PCB Layout  
(Printed-sided View)

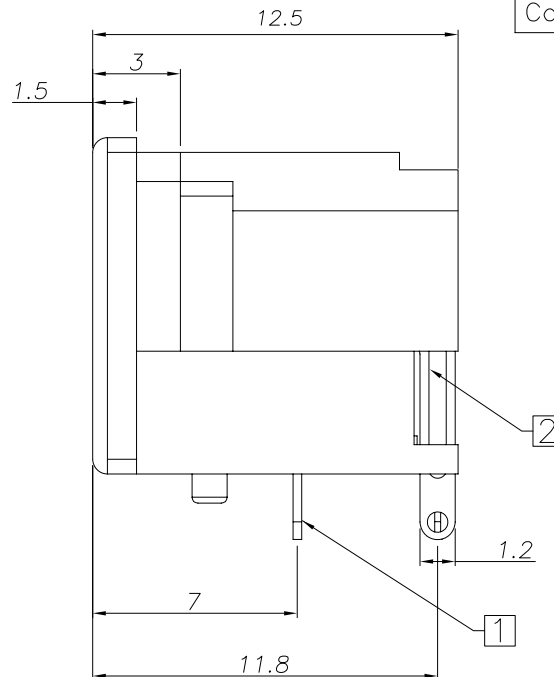
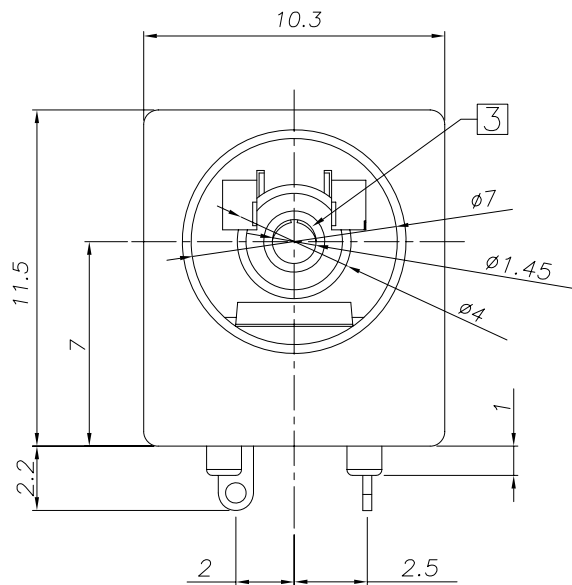
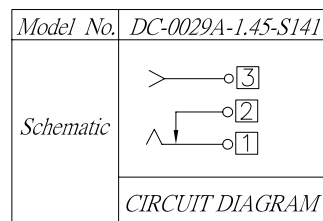
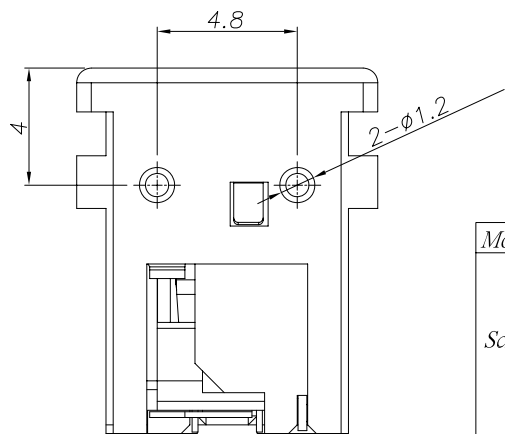

□ : TERMINAL NO.

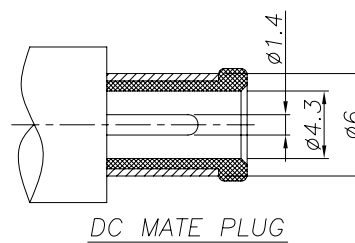

### SPECIFICATIONS

Rating	DC 20V 2.5A ;
Contact Resistance	$\leq 30m\Omega$ ;
Insulation Resistance	$\geq 100M\Omega$ (DC500V) ;
Withstand Voltage	500VAC
Life test	5,000 cycles
Insertion and extraction force	3-30N
General Toleranlce	less than 1 ---> $\pm 0.1$ 1 - 3 ---> $\pm 0.2$ more than 3 ---> $\pm 0.3$

建倚科技股份有限公司  
Contact Technology Corp.  
TEL : 886-2-82271318 FAX : 886-2-82271328

MODEL NAME	DC-0029A-1.45-S141
TITLE	DC JACK
DRAWING NO	DC-0029A-1.45-S141
DATE	2011-05-18

DESIGNED	Vanessa Chang.
CHECKED	Jacky Chen.
APPROVED	Tommy Lin.

SIZE: A4(210x297)
VERSION : A
PAGE : 1 / 1

UNIT : mm  
SCALE: 4/1