

SPECIFICATIONS:

- 1 ELECTRICAL PERFORMANCE
  - CONTACT RESISTANCE 30mΩ Max. ; AFTER RELIABILITY TEST 50mΩ Max.
  - 2 MECHANICAL PERFORMANCE
  - INSERTION FORCE: 3KG Max.
  - 3 ENVIRONMENTAL SPECIFICATIONS: LIFE TEST: 5000CYCLES
  4. TO CONFORM TO SINGATRON HAZARDOUS SUBSTANCE FREE SPECIFICATION.
  5. HALOGEN FREE PRODUCT IDENTIFICATION MARK ON PRODUCT:
  6. HALOGEN FREE PRODUCT IDENTIFICATION LOGO ON PACKAGING:
  - 7.FOR HAND SOLDERING LEAD-FREE PROCESS.
  - 8.PRINTED DATE CODE "WMMDD" ON TOP OF CONNECTOR.
- DATE CODE: WMMDD (DD:DAY MM:MONTH YY:YEAR)

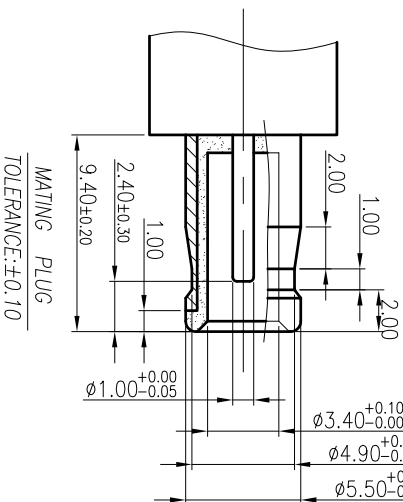
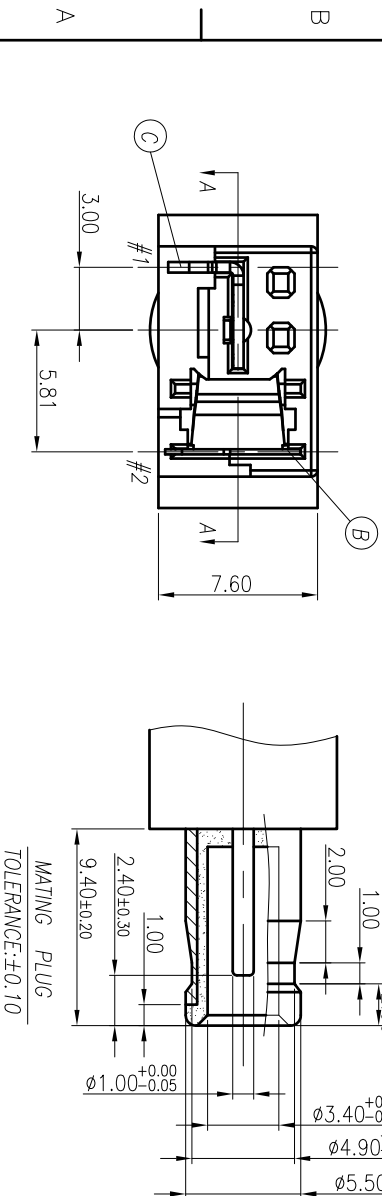
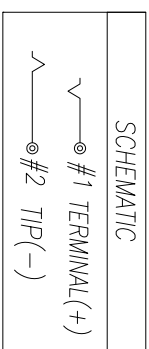
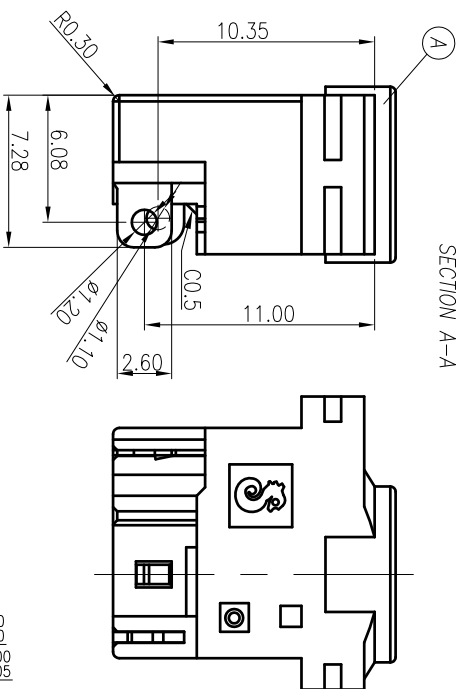
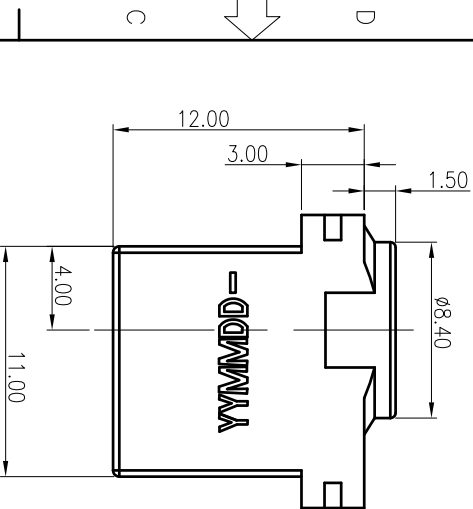

REV	ECN NO	OR DESCRIPTION	REVISED	DATE
B	ECN NO.S081001		Sky	2008.12.10
C	ECN NO.S90438		Sky	2009.06.05
D	ECN NO.S090438-1		Sky	2009.06.19
E	ECN NO.S100720		Soldier	2010.08.12

NO	DESCRIPTION	QTY	MATERIAL	PLATING & COLOR
C	TERMINAL	1	COPPER ALLOY,T=0.50mm	Ag20u"MIN. OVER
B	TIP	1	COPPER ALLOY,T=0.25mm	Ni: 60u" Min.
A	BODY	1	THERMOPLASTIC	BLACK

UNLESS OTHERWISE SPECIFIED TOLERANCES

DECIMALS:	ANGLES:
X : ±0.5	X : ±2°
X.X : ±0.3	X.X : ±1°
X.XX : ±0.2	

TITLE	DC JACK
DWN	Soldier
CHKD	Lussen
APVD	Tony

PART NO.2DC3002-003113  
SCALE:4:1  
UNIT: mm  
SHEET:1 OF 1  
REV: E

Singatron Enterprise Co., Ltd.  
信亨企業股份有限公司

CUSTOMER COPY