

REV.	ECN NO OR DESCRIPTION	REVISED	DATE
A	PRODUCT RELEASE	Even	2008.06.23
B	ECN NO.1080204	LILI	2008.12.29

- NOTE:
1. SEE ZDC1003 SERIES SPECIFICATION.
 2. PACKAGING: TAPE & REEL
 3. TO CONFORM TO SINGATRON HAZARDOUS SUBSTANCE FREE SPEC.
 4. GREEN PRODUCT IDENTIFICATION MARK ON PRODUCT:
 5. GREEN PRODUCT IDENTIFICATION LOGO ON PACKING:
 6. FOR REFLOW SOLDERING LEAD-FREE PROCESS.
 7. PRINTED DATE CODE "YMMDD" ON TOP OF CONNECTOR.

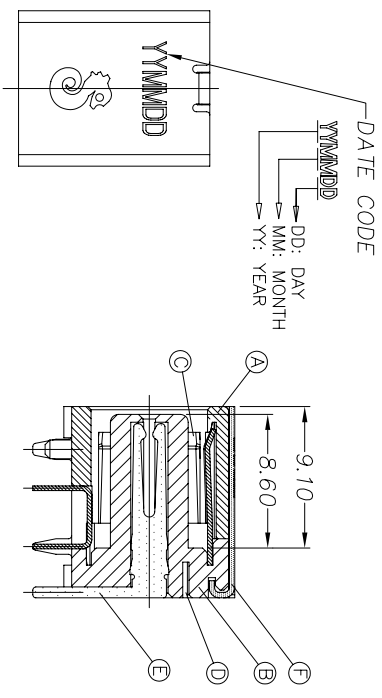

SECTION A-A
SCALE 3:1

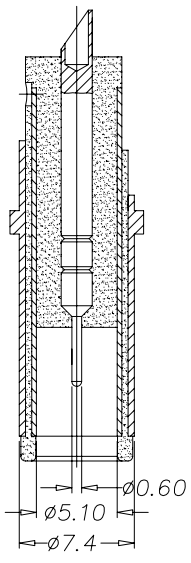
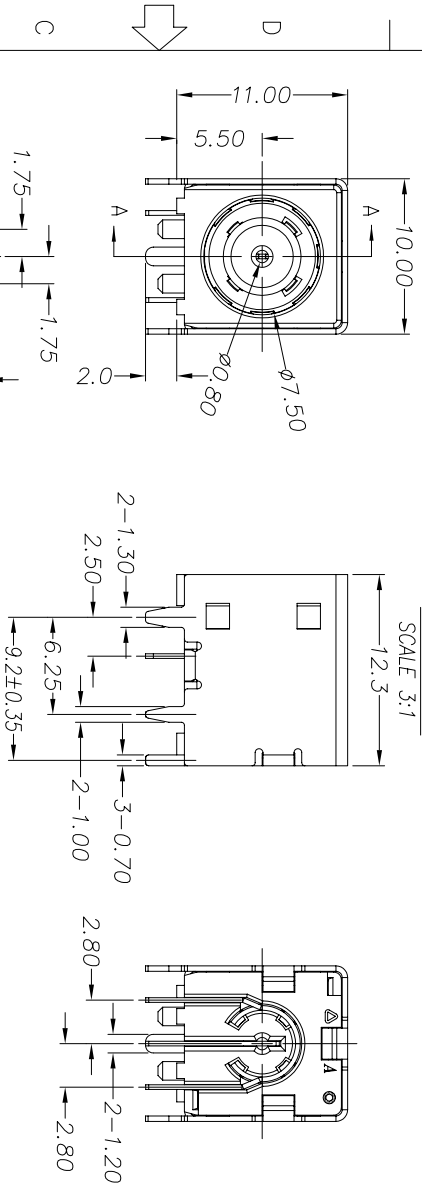

MATING PLUG: OD ϕ 7.4 ; ID ϕ 0.6
Tolerance: \pm 0.05

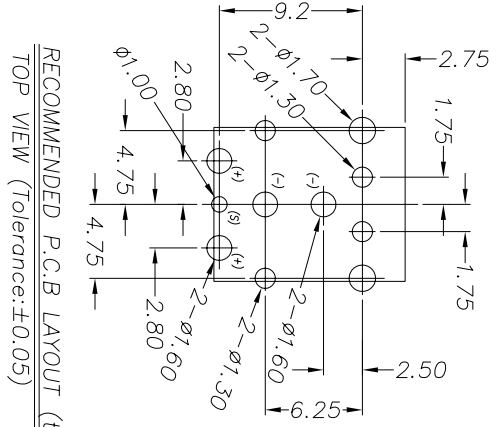
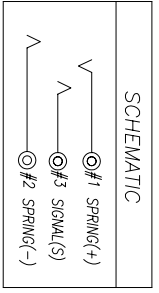

RECOMMENDED P.C.B LAYOUT (t=1.6mm)
TOP VIEW (Tolerance: \pm 0.05)

NO	DESCRIPTION	QTY	MATERIAL	PLATING & COLOR
F	SHELL	1	BRASS 0.35t	NICKEL(60u Min.) PLATING
E	SIGNAL (S)	1	COPPER ALLOY 0.3t	COLD FLASH(\sim 3u) PLATING
D	CONTACT (+)	1	COPPER ALLOY 0.3t	COLD FLASH(\sim 3u) PLATING
C	SPRING (-)	1	COPPER ALLOY 0.3t	COLD FLASH(\sim 3u) PLATING
B	COVER	1	HIGH TEMP. THERMOPLASTIC UL 94V-0	BLACK
A	HOUSING	1	HIGH TEMP. THERMOPLASTIC UL 94V-0	BLACK
NO	DESCRIPTION	QTY	MATERIAL	PLATING & COLOR

UNLESS OTHERWISE SPECIFIED TOLERANCES

Singatron Enterprise Co., Ltd.
信登企業股份有限公司

DECIMALS:	ANGLES:	TITLE
X : \pm 0.5	X : \pm 2°	DC POWER JACK
XX : \pm 0.3	XX : \pm 1°	PART NO. ZDC1003-001111
XXX : \pm 0.2		CHKD Lvsion 2008.12.29 SCALE: 3:1 UNIT: mm
		APVD Mm 2008.12.29 SIZE: A3 SHEET: 1 OF 1 REV: B

CUSTOMER COPY