

REV.	ECN NO OR DESCRIPTION	REVISED DATE
B	ECN NO: 920008	EVEN 2009.7.9
C	0090070-2/2/CHANGE PIN HEAD FROM FULL R TO R	HAHUA 2009.7.14

- SPECIFICATIONS:**
- RATING: DC 20V 5.5A
 - INSERTION FORCE: 0.4Kg~3.0Kg
 - WITHDRAWAL FORCE: 0.4Kg~3.0Kg
 - INSULATION RESISTANCE BETWEEN ANY ADJACENT TERMINALS SHALL NOT BE LESS THAN 100 MEGOHMS BY 500 VOLTS MEGGER.
 - JACK SHALL WITHSTAND 500 VOLTS BETWEEN ANY ADJACENT TERMINAL FOR ONE MINUTE.
 - CONTACT RESISTANCE SHALL NOT EXCEED 0.03 OHMS.
 - JACK SHALL WITHSTAND 5,000 CYCLES OF INSERTION AND WITHDRAWAL WITH TESTING PLUG, AND CONTACT RESISTANCE SHALL NOT EXCEED 0.06 OHMS.
 - MEASURING CONDITION: FROM 5°C TO 35°C. TEMPERATURE: FROM 40% TO 85%.
 - RELATIVE HUMIDITY: FROM 40% TO 85%.
 - PACKING: TAPE&REEL
 - PRINTED DATE CODE: **YMMDD** ON TOP OF CONNECTOR.
 - SOLDER HEAT RESISTANCE: 260°C 10 SECS.
 - TO CONFORM TO SINGATRON HAZARDOUS SUBSTANCE FREE SPEC.
 - GREEN PRODUCT IDENTIFICATION MARK IN JACK: **△**
 - GREEN PRODUCT IDENTIFICATION LABEL IN PACKING: **[G.P. PASS]**
 - FOR LEAD-FREE PROCESS.

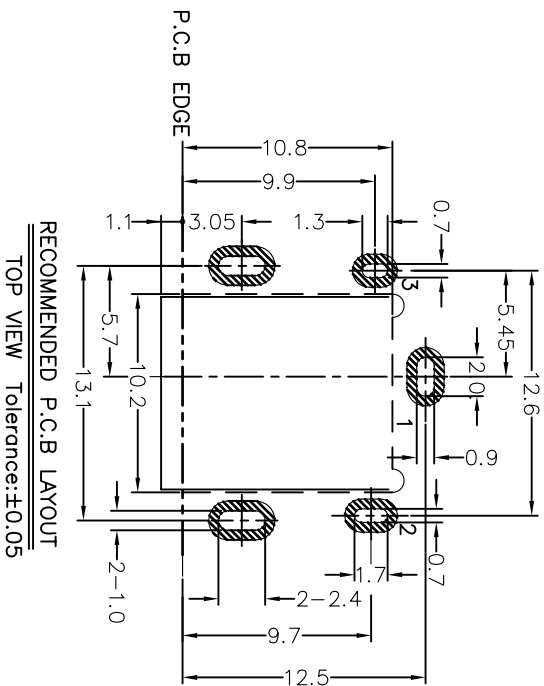
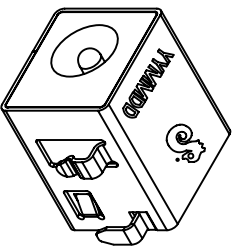
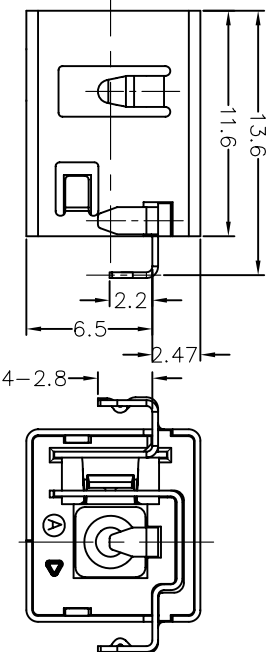
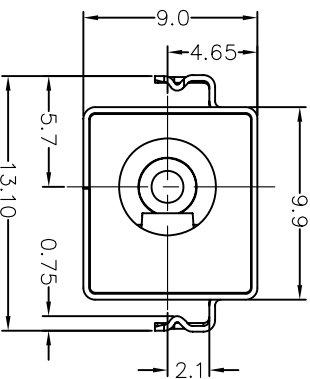
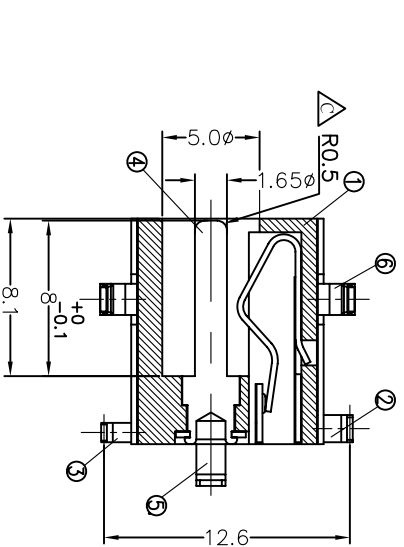
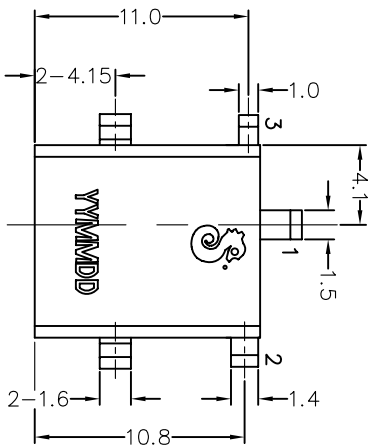
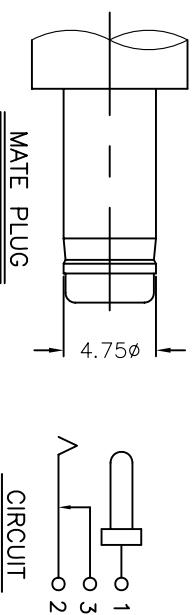
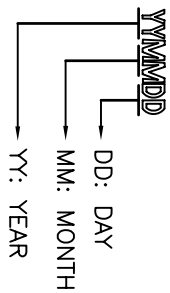

NO	DESCRIPTION	QTY	MATERIAL	BLACK COLOR PLATING & COLOR
A	BODY	1	HIGHT THERMOPLASTIC UHM-0	
B	TIP SPRING	1	COPPER ALLOY 0.3t	SILVER PLATING
C	SHUNT	1	COPPER ALLOY 0.3t	SILVER PLATING
D	CONTACT PIN	1	COPPER ALLOY	NICKEL PLATING
E	TERMINAL	1	COPPER ALLOY 0.3t	SILVER PLATING
F	SHIELDING	1	SPCC 0.3t	NICKEL PLATING

UNLESS OTHERWISE SPECIFIED TOLERANCES

Singatron Enterprise Co., Ltd.
 信登企業股份有限公司

TITLE	DC POWER JACK
DWN HAHUA	PART NO. 2DC-S328-101
CHKD X.X	SCALE 3:1 UNIT: mm
APVD Robin	SIZE: A4 SHEET: 10F1 REV: C

CUSTOMER COPY